

RECLAMATION

Managing Water in the West

Salmon Conservation & Research Facility Permanent Flow Delivery Appraisal Study Report

**Central Valley Project
Friant, California**

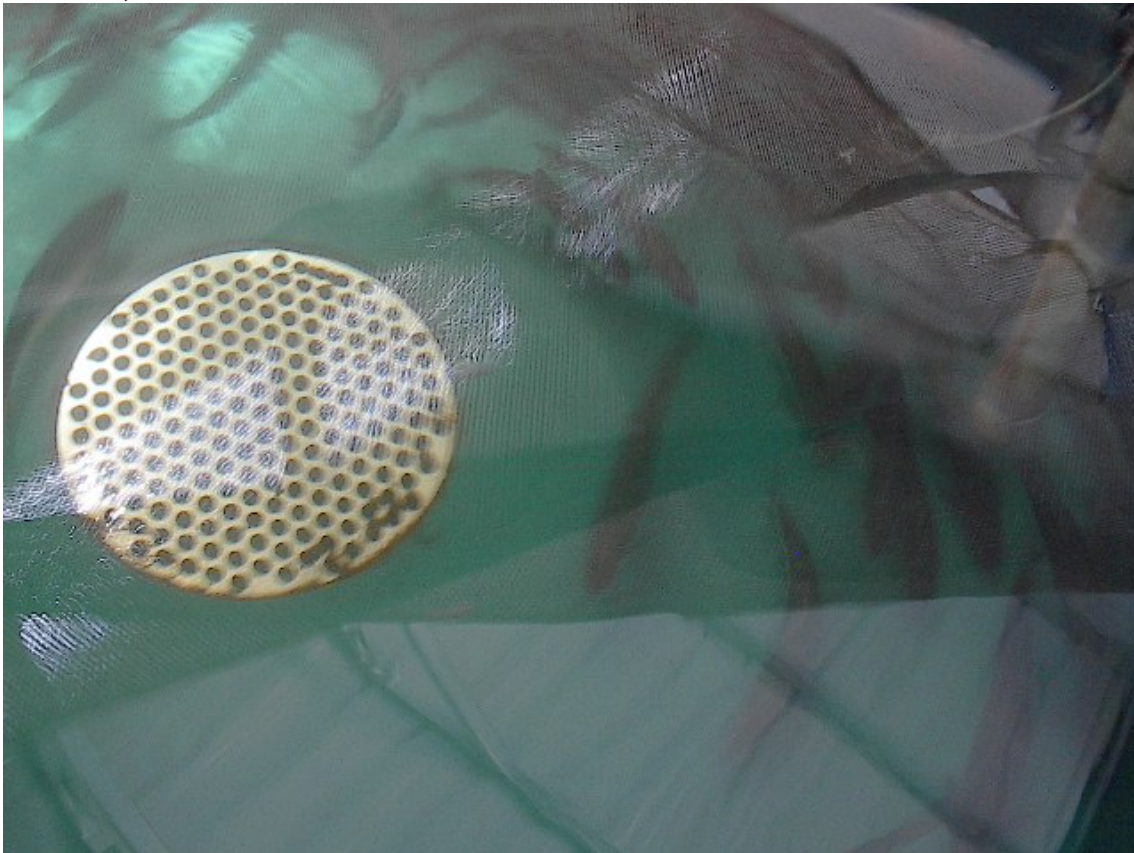

**U.S. Department of the Interior
Bureau of Reclamation**

**Technical Service Center
Denver, Colorado**

May 2013

Mission Statements

The mission of the Department of the Interior is to protect and provide access to our Nation's natural and cultural heritage and honor our trust responsibilities to Indian Tribes and our commitments to island communities.

The mission of the Bureau of Reclamation is to manage, develop, and protect water and related resources in an environmentally and economically sound manner in the interest of the American public.

Salmon Conservation & Research Facility

Permanent flow delivery

Appraisal Study Report

Friant, California

Jeremy M. Lorberau (86-68140)
Author

W. Chris Duke, P.E. (86-68140)
Peer Reviewer

Tim P. Brown, P.E. (86-68140)
Manager, Water Conveyance Group

Date

REVISIONS					
Date	Description	Prepared	Checked	Technical Approval	Peer Review

Acronyms

ACI	American Concrete Institute
AWWA	American Water Works Association
CDFG	California Department of Fish and Game
CDFW	California Department of Fish and Wildlife (formerly CDFG)
CDWR	California Department of Water Resources
cfs	Cubic feet per second
DR	Dimension Ratio
FCWWD18	Fresno County Water Works District #18
FERC	Federal Energy Regulatory Commission
FKC	Friant-Kern Canal
FPA	Friant Power Authority
gpm	Gallons per minute
HDPE	High density polyethylene
ID	Inside diameter
NOAA	National Oceanic and Atmospheric Administration
O&M	Operations and Maintenance
OCID	Orange Cove Irrigation District
OD	Outside diameter
PE	Polyethylene
PRV	Pressure Regulating Valve
PSF	Pounds per square foot
PSI	Pounds per square inch
SCADA	Supervisory Control and Data Acquisition
SCARF	Salmon Conservation and Research Facility
SJR	San Joaquin River
SJRRP	San Joaquin River Restoration Program
TSC	Bureau of Reclamation Technical Service Center
USBR	United States Bureau of Reclamation

Table of Contents

I.	INTRODUCTION	6
A.	Background	6
B.	Project Purpose and Need	6
C.	Study Objectives	7
D.	Previous Studies & Reports	7
E.	Anticipated Future Actions	7
II.	PROJECT COMPLICATIONS	8
A.	CDFW Hatchery Water Storage	8
B.	Water Sources and Conveyance of Flows	8
C.	Hatchery Temperature Requirements	9
D.	Safety of Dams Requirements	10
E.	Concurrent Studies at Friant Dam.....	10
III.	STUDY ALTERNATIVES	10
A.	No Action Alternative.....	10
B.	Alternative 1 – Piping from Friant Dam.....	10
C.	Alternative 2 – Groundwater Wells.....	16
IV.	FINDINGS.....	26
A.	Construction Cost Estimates.....	26
B.	Real Estate Costs.....	29
C.	Actions for Future Studies	29
D.	Project Recommendations	30
E.	Study Conclusions	31
V.	REFERENCES & APPENDICES	32
A.	REFERENCES	32
B.	APPENDIX B – Figures and Drawings.....	33
C.	APPENDIX C – Cost Estimates	A
D.	APPENDIX D – USBR DRAWING 40-D-6551.....	A

I. INTRODUCTION

A. Background

The California Department of Fish & Wildlife (CDFW) (previously known as California Department of Fish & Game) currently operates a trout hatchery at their facility in Friant, California. In addition to the existing trout hatchery, CDFW is planning to establish a salmon hatchery facility adjacent to the trout hatchery. The two facilities would be operated separately to prevent spread of disease between salmon and trout. This new salmon facility will be known as the Salmon Conservation and Research Facility (SCARF). The Conservation Facility is part of the San Joaquin River Restoration Program (SJRRP) strategy to reintroduce a self-sustaining spring-run Chinook salmon population to the San Joaquin River. The objectives of the SCARF include:

- The development and maintenance of a genetically diverse brood stock of spring and potentially fall run Chinook to support the restoration of Chinook salmon to self sustaining levels per the Settlement and Act and in accordance with applicable Program guidance.
- Production of juvenile spring run Chinook, and potentially fall-run Chinook, to support the restoration of Chinook salmon runs to self sustaining levels per the Settlement and Act and in accordance with applicable Program guidance.
- Support and provide research needs associated with restoring spring and/or fall run Chinook populations to self-sustaining levels per the Stipulation of Settlement in *Natural Resources Defense Council, et al. v. Kirk Rodgers, et al.*, the San Joaquin River Restoration Settlement Act, and in accordance with applicable SJRRP guidance.

The new SCARF facility will be located on the existing CDFW property located in the town of Friant, California, approximately 1.75 miles downstream of Friant Dam on the SJR. CDFW has developed an Interim Facility to conduct captive fish rearing experiments at the future site of the SCARF. The Interim facility currently consists of a series of small holding tanks, a water delivery and pumping system, and a structure to house the juvenile salmon. To date, the Interim Facility has been operating on a water budget of 0.2 cubic feet per second (cfs) taken from the 35 cfs flow currently delivered to the CDFW trout hatchery. In 2015, the flows are scheduled to be increased to 20 cfs, which will be the permanent flow rates for use in the SCARF. CDFW's schedule projects the SCARF to be fully operational by the end of 2015, with the first year of Chinook salmon delivered to the SJR in 2016.

B. Project Purpose and Need

At the request of the SJRRP Program office in Sacramento, California, the Bureau of Reclamation's Technical Service Center was asked to conduct an Appraisal level study for options to deliver 20 cfs of water to the SCARF. This report documents the Appraisal level design findings, costs and construction schedule which were studied and found to be required to support a flow of 20 cfs to the SCARF. The San Joaquin River Restoration Program, and associated actions including this study, is authorized under Public Law 111-11.

C. Study Objectives

The objective of this Appraisal level study was to develop and evaluate the requirements and costs for two alternatives to deliver 20 cfs of SJR/Lake Millerton water to the SCARF. The designs and costs for these two alternatives were developed to the Appraisal level as defined by current Technical Service Center (TSC) guidelines and standards. Other groups consulted at TSC during this study were the Cost Estimating & Scheduling, Mechanical, Electrical, Hydropower Diagnostics & Supervisory Control and Data Acquisitions (SCADA), and Plant Structures groups.

The deliverables for this study were: Appraisal level designs, quantities, cost estimates, construction schedules, draft design figures, and a design report. The delivery schedule for these items is March 2013, which was chosen to support the implementation timeframe for this project (project online in 2015 and producing salmon by 2016).

D. Previous Studies & Reports

Prior to TSC beginning work on this project, CDFW had initiated preliminary studies to deliver between 2 and 20 cfs flows to the new SCARF hatchery. These studies were not completed at the time of this report, and therefore, no finalized report details were incorporated into this study. However, discussions and coordination meetings were held with CDFW staff, and a site visit was conducted, to determine what preliminary findings had been determined. These findings were incorporated when possible into the designs for this study.

Before starting the Appraisal level study, a request was made by the SJRRP Office to evaluate the treatment requirements to provide 2 cfs of San Joaquin River water from below Friant Dam to the SCARF. In response to this request, a report was developed by TSC to the Preliminary design level, which documented two separate treatment methods: chlorination and ultraviolet light exposure. The total capital cost (preliminary costs only, not for construction or appropriations) for the chlorination option (Preliminary Treatment Option 1) was \$836,950, with an annual \$38,000 cost for Operations and Maintenance. The total capital cost (preliminary costs only, not for construction or appropriations) for the UV exposure option (Preliminary Treatment Option 2) was \$457,500, with an annual \$14,000 cost for Operations and Maintenance. The full details of this preliminary report can be found in Appendix A: Reference 1.

E. Anticipated Future Actions

It is anticipated that the results of this study will be used to select a preferred alternative for this project. The preferred alternative selected will then be further evaluated during subsequent design studies. It is currently undetermined if TSC will perform these future studies and designs or if CDFW will take over further development of the project after this study. It is anticipated that the final alternative for this project will be designed by early 2015. Construction is scheduled to occur during the 2015 calendar year to enable the facility to be on-line by the fall of 2015. It is anticipated that the first hatchery year of Chinook salmon will be delivered to the SJR by 2016 to support the Restoration Goal of the SJRRP.

II. PROJECT COMPLICATIONS

There are a number of existing conditions that add complication to this project. Each of these complications is further explained in detail below:

A. CDFW Hatchery Water Storage

The first complication found during this study was that no water storage facility existed at the CDFW hatchery. In current operations, the CDFW facility receives a constant 35 cfs from Friant Dam/Lake Millerton via a pipeline. These flows are taken out of either the Friant-Kern Canal outlet works or the San Joaquin River outlet works at Friant Dam. These flows are routed through a series of pipes, through a pair of mixing valves, and into the Orange Cove Irrigation District power generation facility. The 35 cfs flows generate electrical power at this facility, based on the details and requirements of Federal Energy Regulatory Commission (FERC) license #FRO-427, PRJ-17.000 and United State Bureau of Reclamation (USBR) Contract No. 0-07-20-X0308. The flows are conveyed from this facility to the CDFW hatchery aeration towers via a 45-inch welded steel pipe. After flows pass through the aeration towers at the CDFW facility, they are routed into the various parts of the hatchery as required. Without the ability to store water at this facility, any interruption of service (power outage, mechanical failure, construction, etc.) will cause the CDFW hatchery to enter emergency conditions. This emergency condition, if not remedied immediately, could lead to the loss of the entire fish population at this hatchery. Thus, without existing storage or a temporary water supply being added, any construction on this project would cause the hatchery to enter emergency conditions. It was determined during the study that a temporary water supply would be required for Alternative 1 to ensure flows were maintained to the trout hatchery. This temporary water supply was designed as a pump system taking water from the SJR downstream of Friant Dam near the CDFW property, and delivering it directly into the aeration tower draft tubes. Alternative 2 only affects the SCARF, therefore a temporary water supply was not included.

B. Water Sources and Conveyance of Flows

The next complication found during this study involved the implementation of flows to the SCARF complex. Currently, the CDFW hatchery receives 35 cfs, of which 0.2 cfs is allocated to the SCARF. In 2015, the SCARF is scheduled to receive 20 cfs, while the trout hatchery continues to receive 35 cfs. All flow to the trout hatchery currently must pass through a power generating facility operated by Orange Cove Irrigation District (OCID). OCID is limited to diversion of 35 cfs for power use at this facility through licenses from the California State Water Resources Control Board. CDFW's water service agreement with Reclamation for non-consumptive use at the trout hatchery is also limited to 35 cfs. Thus, the 20 cfs addition to flows cannot be realized without modifications. In addition to the regulatory constraints above, the turbine-generator set at the OCID power generating facility is flowing at its rated nameplate capacity of 35 cfs. If additional flows were to be routed through the OCID facility, the turbine-generator set would be pushed beyond the rated capacity, causing an increased risk of failure and additional operating and maintenance (O&M) requirements. Routing the additional 20 cfs flows around the OCID facility, the existing 45-inch diameter pipeline could be used to deliver water to the CDFW hatchery (trout hatchery and the SCARF) using the existing infrastructure. Thus, the study developed an alternative, which is explained in detail in Alternative 1 – Piping from Friant Dam.

In addition to the flow complications at the OCID facility, it was found that the existing piping from the outlets at Friant Dam to the OCID facility would convey the increased flows at an unacceptably high velocity. The high velocity flows can cause a number of problems, including: increased O&M requirements, valve and gate seal failures, increased risk of high hydraulic transient pressures, increased thrust loads on pipes and thrust blocks, additional head losses which cause lower generating capacities at the OCID facility, and other issues. For these reasons, it was determined that a 30-inch diameter pipe would replace the existing 18-inch to 24-inch pipeline, and would convey the flows from the SJR outlet works to mixing valves upstream of the OCID facility. The existing Friant-Kern Canal (FKC) outlet works conveyance pipeline to the mixing valves is a 30-inch diameter welded steel pipe, which did not require replacement for this project. See Appendix B for a figure showing the existing and proposed pipelines. By replacing the existing 18-inch to 24-inch diameter pipeline with a new 30-inch diameter pipeline, the velocities were reduced from an approximate average high velocity of 34 feet/second to 11 feet/second. The 11 feet/second velocity would be comparable to, or slightly less than, the current flow velocities in the existing pipelines. Additionally, many of the risks above were mitigated for or avoided by increasing the diameter of the conveyance pipeline, while still providing for the necessary increased total flow of 55 cfs.

C. Hatchery Temperature Requirements

Another complication that arose during this study was the temperature variations found in Lake Millerton, and their effect on the fish at the CDFW hatchery. The FKC outlet works draws water from Lake Millerton approximately 75 feet above the SJR outlet works. When flows are taken from the lake at this reduced depth, there is an increase in water temperature. This is due to additional surface warming effects by the sun & environment that do not extend as far down into the Lake Millerton pool. Thus, the water taken out of the SJR outlet works is typically cooler than water taken from the FKC outlet works. Temperature data has been collected intermittently since 2004 at each of these outlet works by TSC for various other on-going projects. This temperature data was analyzed, and incorporated into this study. Additionally, some temperature data had been collected at the CDFW hatchery aeration towers, which was also incorporated into this study. To determine the temperature requirements for the target fish species at the hatchery, guidance was sought by TSC from CDFW. A draft position paper was forwarded to TSC that contained a range of temperatures for both Fall-run and Spring-run Chinook salmon. The range of temperatures provided included a minimum and maximum value, as well as a preferred range for each species based on different periods of the year. These preferred temperature range values were used as targets for the temperature analysis conducted by TSC. By selecting a range of flow (from 0% to 100%) from each outlet works, and pairing that with the recorded temperature data collected, a composite temperature could be determined for the flows downstream of the mixing valves. By comparing this composite temperature value to the recorded temperatures at the CDFW aeration tower, a value could be calculated for the temperature gain or loss in the delivery pipeline. Using these values, an operational scheme was prepared for this study which recommended settings for each mixing valve that would deliver flows within the preferred range needed at the hatchery. This mixing scheme was incorporated into Alternative 1. Alternative 2 used water from groundwater well sources and a large underground storage tank that will maintain the water temperature within the preferred range required at the hatchery.

D. Safety of Dams Requirements

The next complication found during this study was the modification to Friant Dam in Alternative 1, which is an existing USBR structure. Because this is a large storage dam, it falls into both the California and Federal Safety of Dams programs. Though the project is not modifying the dam itself, Alternative 1 proposes changes at the SJR outlet works. This proposed change will require a review and project acceptance by both the California Department of the Safety of Dams, and the USBR Safety of Dams program, if Alternative 1 is chosen as the preferred alternative.

E. Concurrent Studies at Friant Dam

The final complication found during this study was that there were other, concurrent studies being developed for the areas at Friant Dam that are affected by this study. The study with the highest potential to impact this project is a study currently being conducted to deliver up to 4.5 cfs to Fresno County Water Works District #18 (FCWWD18). This study plans to utilize the older, existing mixing valve vault north of the OCID facility, and the existing 18-inch to 24-inch line from the SJR outlet works and/or the existing 18-inch line (High Level Supply line) from the FKC outlet works. By replacing the existing SJR outlet works line from the existing 18-inch to 24-inch pipe to a new 30-inch pipe; this additional flow would be conveyed with less headloss and lower velocities. This would be beneficial to all parties involved for reasons listed above in the Water Sources and Conveyance of Flows section. The remainder of the construction work proposed for Alternative 1 would not affect or interfere with the work being studied by FCWWD18.

III. STUDY ALTERNATIVES

A. No Action Alternative

If neither of the proposed alternatives is implemented, then the SCARF will not receive a stable long-term supply of water to support Chinook salmon production. With the SCARF not able to produce the necessary Chinook salmon, these fish would not be readily available to support reintroduction required for the SJRRP. There is no other known method to produce juvenile salmon on a scale meaningful for SJRRP reintroduction. Salmon produced at other facilities would be subject to greater transport stress, and would be anticipated to have higher rates of adult straying without the benefit of imprinting as juveniles reared in San Joaquin River water. These factors would combine to reduce the overall effectiveness and survivability of the population in the SJR. Therefore, it would be more difficult, more expensive, and take longer to establish a Chinook salmon population in the SJR as required by Public Law 111-11. For these reasons, the No Action Alternative is not recommended.

B. Alternative 1 – Piping from Friant Dam

The design basis and intent of this alternative is to deliver water from Lake Millerton, through Friant Dam, using upgraded infrastructure upstream of the OCID power plant and the existing 45-inch diameter pipeline between the OCID power plant and the CDFW trout hatchery.

This alternative requires a new allocation of 20 cfs taken directly from Lake Millerton. This new allocation would be in addition to the existing 35 cfs allocation for the CDFW trout hatchery. The additional 20 cfs would be taken through the FKC outlet works, the SJR outlet works, or a

combination thereof, depending upon water temperature, O&M conditions, and other parameters. If the additional flow (20 cfs) was taken through the FKC outlet works, it would be routed through the existing 30-inch diameter penstock pipe that runs down the right face of Friant Dam, and into the existing mixing valves near the OCID power generating facility. If the additional flow (20 cfs) was taken from the SJR outlet, it would be routed through taps in the No. 1 and 2 110-inch penstocks, through a new 30-inch conveyance pipeline, and into the existing mixing valves near the OCID facility. At this point, the entire flow (55 cfs) would be routed through the mixing valves, and into a 30-inch pipe just upstream of the OCID facility. A tee with control valves would pass 35 cfs into the OCID facility, and divert 20 cfs around the facility and into a 24-inch bypass pipeline. This bypass pipeline would contain an isolation valve, a magnetic flow meter, and two pressure regulating valves. The 35 cfs flows through the OCID facility would operate as they currently do, with no changes proposed. After the 35 cfs flows exit the OCID facility, they enter the 45-inch pipeline which runs to a flow meter located in the yard near the Friant Dam administration building. The 24-inch bypass pipeline would terminate in a tee, which would be welded into the existing 45-inch pipeline located upstream of the yard flow meter. At this point, the 20 cfs and 35 cfs flows would be recombined. See Appendix B for a figure showing the proposed piping for this alternative. This combined flow would be conveyed through the 45-inch pipeline, to the CDFW hatchery aeration towers. The aeration tower facility, located at the CDFW hatchery, was the delivery demarcation point identified for this study. It is assumed that the flows would be split by CDFW between the trout hatchery and the SCARF. No details or estimates for this split are included in this study.

This alternative has a series of civil and mechanical features that were designed during the development of this study. In addition, there are a series of potential electrical and SCADA options that could be added to the project for convenience. These options were not designed at this Appraisal level, but are identified below to be included in future studies if deemed advantageous.

Civil Items:

The primary civil features of this alternative are the conveyance pipelines, related earth work, the reinforced concrete vault structures, and the temporary water supply during construction. Each of these features is discussed in detail below.

The first major feature of this alternative is the increased diameter conveyance pipeline which runs from the SJR outlet works to the existing mixing valves. This pipeline was deemed necessary for hydraulic reasons, including unacceptably high velocities in the pipeline and the related risks posed by this condition. This condition was determined by performing hydraulic flow calculations and modeling of the pipeline, including a transient analysis study. Hydraulic calculations were conducted using Microsoft Excel and Bentley WaterHammer analyses. The analyses were completed in accordance with TSC Design Standards Number 3, Chapter 11: General Hydraulic Considerations, 1994. Based on these analyses, it was found that a welded steel pipe would accommodate both the flows and pressure/transient requirements created in this alternative. It was determined that a 30-inch diameter pipeline would convey the required 55 cfs at an acceptable velocity. This new pipeline would also reduce the headloss in this pipe segment. The proposed pipeline would be epoxy coated to resist corrosion and environmental effects. The pipeline would have an epoxy lining to reduce the friction and headloss, as well as the internal corrosion effects inside the pipe. The pipe wall thickness for handling, pressure, and transient

surge head was found to be 0.375 inches thick. The pipe was designed to accommodate the full elevation head from Friant Dam, which is approximately 265 feet, or approximately 115 pounds per square inch (psi). The pipe was also designed to handle a vacuum pressure of -5 psi. Finally, the pipe was designed to handle deflections up to 3%, based on the epoxy coating and epoxy lining. The wall thickness was utilized for the entire length of the pipeline, from the SJR outlet to the mixing valves.

To accommodate the new pipeline, the existing 18-inch pipeline, which is enlarged to 24-inch at the edge of the gantry crane pad, would be removed. This removed pipeline runs across the yard near Friant Dam, terminating in a 24-inch to 30-inch enlarging elbow near the mixing valves. This elbow is flanged to the existing mixing valve, and would be removed and disposed of during this alternative. The existing flange of the mixing valve would serve as the termination point for the new 30-inch pipeline.

This 30-inch pipe would be connected to the No. 1 and 2 110-inch penstocks as detailed in the Mechanical Items section below. It would then run approximately 10 feet above ground, across the yard near Friant Dam, to the mixing valve flange termination point. This is shown on the Figures and Drawings in Appendix B. The pipe would be supported above ground by new reinforced concrete saddle blocks placed for this purpose. The existing saddle blocks that support the current pipe would be demolished and removed after the existing pipe was removed. Where the pipe daylights into the hillside, it would transition into a Type 2 trench constructed for this alternative. This pipe trench would consist of a 4-inch uncompacted bedding, native fill material compacted to 0.7 of the outside diameter (OD) (to support the flexible pipe), and uncompacted earth fill to the original grade elevation. In locations under roadways or other vehicle areas, the backfill would be fully compacted. The pipe and trench would continue to the existing angled tee that connects to the abandoned mixing valve vault near the OCID facility. This existing 24 x 24 x 24-inch tee would be removed and replaced with a 30 x 24 x 30-inch tee to accommodate the new pipe diameter, while still providing the connection to the abandoned mixing vault (to be potentially used by FCWWD18 as noted above). The 30-inch pipe would then be routed along the current alignment, around the abandoned vault, and to the existing mixing valve. A reinforced concrete thrust block would be placed as needed at the horizontal bends to support the pipe and thrust forces generated. The pipeline would terminate at the flange of the existing 30-inch mixing valve.

A secondary pipeline is required for this alternative, which is called the bypass pipeline. This pipeline is to be a 24-inch diameter, welded steel pipe, with properties similar to the pipe above. It will have the same epoxy coating and epoxy lining. This pipe will be located entirely underground, and will be placed in a pipe trench similar to the 30-inch pipe above. This pipe will start at a tee inserted into the 30-inch line running between the existing mixing valves and the OCID power generating facility. This pipe will have an isolation valve located immediately downstream of the tee, for emergency shutoff and maintenance purposes. The pipe will then continue to a magnetic flow meter, which will measure the flow passing through the pipeline. This flow meter has the option of having SCADA controls added later to automate the operations of this bypass pipeline. It is anticipated that if this option is to be designed, the SCADA controls would send a signal to the PRV's, which function as throttling valves and control the flow rate through the bypass pipeline. Currently, the PRV's will be manually set for a continuous operation, and the flow meter will read current flow values and report them on a local display.

The flow meter will be located in a reinforced concrete vault, which is explained below. The pipe will pass through the two opposite walls of the vault, and continue to the PRV vault downstream. It is necessary to maintain an approximate 10 diameters of straight pipe upstream and approximately 5 diameters downstream of the flow meter to have an accurate measurement. The layout shown in Appendix B incorporates these required distances. The PRV vault will be similar to the flow meter vault, though larger in size, and is also explained in detail below. Similar to the flow meter vault, the pipe will pass through the two opposing walls, underground, into the vault. The pipe will exit the vault and continue to a new tee to be inserted into the existing 45-inch pipe downstream of the OCID facility. The tee will be a welded steel tee, 45 x 24 x 45, with similar coating and lining as the 24-inch bypass pipe. The tees will be welded into their respective pipes during a scheduled shutdown period. This shutdown period will require a temporary source of water to the hatchery, which is detailed below.

The earth work for both pipes is similar in design, and is a Type 2 trench matching TSC design standards. This trench type and details can be found on USBR drawing 40-D-6551, shown as Appendix D. The typical trench section is proposed to be excavated to a total depth of 10 feet, with 1 foot of stripping included at the top. The 1 foot depth of stripping was chosen to include the lawn and top soil found in the yard near the dam. The 10 foot depth was chosen to account for the varied topography and hill slopes at the site, as well as to match and clear numerous existing utilities and pipelines. The trench was designed to include an uncompacted bedding depth of 4 inches under the invert of the pipe, which provides for proper support. Since the pipe is designed to be welded steel, it is considered a flexible pipe material. Therefore, a native embedment material will be placed from the invert elevation above the bedding to a height of 0.7 of the outside diameter and compacted. For the 30-inch line, this is equivalent to approximately 21 inches. For the 24-inch line, this is equivalent to approximately 16.8 inches. This embedment material is chosen to transfer the loading on the pipe from the steel into the walls of the trench. For this design, a soil E' value of 1,000 psf was chosen, based on the limited geotechnical information at this site. This soil pressure is assumed to be adequate for weak soils, containing fine silts and sands, or other non-load bearing soils. This geology matches other sedimentary soils found near this site, along the SJR. For this design, a time factor of 2.5 was chosen, and a design factor of 0.67 was chosen. The trench bottom width was chosen to provide at least one outside diameter clearance at the pipe springline. A two horizontal to one vertical slope was chosen for excavation, based on the short duration of the construction work and the angle of repose of the anticipated soils to be present. The embedment around the pipe will be compacted to a minimum 95% relative compaction (standard Proctor), similar to other USBR pipe projects. All fill placed above the compacted embedment will be set in lifts, with no testing or compaction requirements. No vehicle loading will be allowed until there is a minimum of 3 feet of fill over the pipe. The top 1 foot of backfill will be replaced using the material stripped previously, including the lawn and gravel surfacing near the face of Friant Dam. No groundwater is assumed to occur that requires site dewatering in the pipe trenches, based on the low water table and invert elevation of the trenches. However, it is anticipated that site unwatering will be required to remove precipitation and other inflows into the excavated trenches. It is expected that the worst-case scenario for unwatering would be a 12-hour rainfall condition based on a 2-year design event. These values were chosen to accommodate the anticipated construction duration, and the typical workday length. It is anticipated that any storm lasting longer than the 12-hour event would be forecasted, and preparations could be made to cover the open trench or install other protective features. The National Oceanic and

Atmospheric Administration (NOAA) rainfall rates anticipated for this area are 2 inches per hour, based on the 12 hour storm and a 2 year event. Site unwatering pumps were included in the design, and consisted of a 50 gallon per minute (gpm) pump for each trench. The 50 gpm size was chosen to completely remove the 2 inch rainfall volumes from the open trench for the chosen storm event.

The next major civil features of this alternative are the reinforced concrete vaults that house the flow meter and PRV's. There are two vaults included in this alternative, one for the flow meter, and one for the two PRV's. Each vault is designed with similar properties, while the size varies to fit the necessary mechanical accessories. Each vault is located in an excavation that is 10' deep, with 2:1 side slopes similar to the pipe trenches above. This depth matches the pipe depths chosen, and locates the mechanical features in line with the pipelines. Both vaults have reinforced concrete walls that are 1 foot thick, with a slab that is 1'-1" thick. At this design level, specific reinforcement has not been designed for these walls and slab. For this study, a typical value of 150 pounds of steel per cubic yard of concrete was used for estimating purposes. The top deck of these vaults is made from aluminum grating, which is 2 inch thick I-bar grating. The grating deck was chosen to match other vaults at this site and to provide access to the mechanical features. An access ladder with a safety ascent system will be mounted on one wall of the vault to provide for safe ascent and descent into the space. The space around the vaults, previously excavated, will be backfilled after construction using structural backfill, compacted to a 95% relative compaction (standard Proctor). The vaults will project approximately 6 inches above the original grade level, to prevent incidental flows from entering them. Finally, a series of protective steel bollards, filled with concrete, will be installed between the adjacent roadway and the vaults to protect them from vehicular damage. The size of the flow meter vault was chosen to be 8 feet by 10 feet, outside dimensions, to fit the mechanical meter, fittings, and necessary pipe connections. The size of the PRV vault was chosen to be 8 feet by 16 feet, outside dimensions, to fit two PRV valves, fittings, and necessary pipe connections.

As noted above, the installation of the two steel tees will disrupt the water supply to the CDFW hatchery. It is anticipated that these two tees will each take approximately 2-3 days to install. A total flow outage window of seven days, plus additional time for an acclimation period, was estimated for this alternative where a temporary water supply would be required. Based on discussions with the SJRRP office, it was decided to recommend rental of a portable trailer mounted pump. This unit would be rented, delivered, and have the necessary intake and discharge lines setup before any work was done that could interrupt the flow to the hatchery. This temporary water supply is necessary because no water storage is currently available at the hatchery. It is anticipated that the pump unit will be located on the northwestern edge of the CDFW property, and would take water via snorkel pipes directly from the SJR. The intake location would be chosen to minimize sediment and other contaminants from entering the pump, and thus being delivered to the hatchery. Further review of this alternative proposal should be conducted with CDFW staff to confirm that this design option will accommodate their water temperature, quality, and other needs. For this alternative, the temporary pump will deliver a minimum of 35 cfs to the aeration tower afterbay. From this location, it can be delivered to the trout hatchery via the existing CDFW infrastructure. Based on discussions with CDFW, it is understood that an acclimation period should be provided so that the fish can adjust to the new water source. To accomplish this, it is recommended that the temporary pump be started in a low-flow mode, mixing the existing water supply with the river supply in an increasing ratio.

This can be continued until the temporary pump is supplying the full 35 cfs required. To adjust the fish back to the original supply, a reverse process can be utilized. Details regarding this adjustment period have not been refined at this design level, and are left to be completed during a future study.

Mechanical Items:

For up to 55 cfs design flow, the two existing 110- x 96-inch cast-iron flanged reducers that are between each of the two hollow-jet valves and existing 110-inch steel pipes will be removed and replaced. The existing 18-inch diameter steel pipes will be removed. The two existing 18-inch gate valves will be kept, along with the adjoining 18-inch pipes and elbows. Each existing 96-inch hollow-jet valve must be temporarily removed, moved to provide clearance for the installation process, and then re-installed.

New welded steel 24-inch outlet bifurcations, which tap into new welded steel 110- x 96-inch flanged reducers, will be installed at 2 locations. New 110-inch by 96-inch reducers will be needed, because the new steel piping cannot be welded to the existing cast-iron reducers. The existing 18-inch pipes with the gate valves will be reinstalled on the new reducers, and tee into the new 24-inch pipe at 2 locations. These two 24-inch pipes will then manifold into one 30-inch pipe.

For the 20 cfs flow through the proposed 24-inch bypass pipe, two new 24-inch pressure-reducing valves in series will be installed. Two pressure-reducing valves will be needed because of the high pressure drop from upstream to downstream present at the OCID powerhouse. The PRV's are also required to prevent cavitation and to be within each valve's best operating range.

A magnetic flowmeter system was chosen for Alternative 1 due to its ability to provide 0.5% to 1.0% accuracy for water velocities above 1 foot/second and unobstructed flow through the flowmeter. The flowmeter will be located within a concrete vault to protect it from the elements and vandalism.

Electrical/SCADA Items:

The valves and flow meter recommended for this alternative are designed to be manually operated. There is an option to convert these devices to electric motor operation with SCADA controls, which could be added at a later time. Additionally, the manual operation mode proposed mimics the current operation of the valves and gates currently used, except in the OCID facility. The details of the current OCID controls, SCADA system, and other electrical features were not provided for this study. If this alternative is selected as the preferred alternative, and the option to incorporate electronic controls and SCADA features is included, then this system should be investigated and the costs for it added into the project.

Other Items:

To construct this alternative, the project must be coordinated with other on-going projects at this site. At present, there are proposed projects that would deliver water to FCWWD18 using the same pipelines as those that are planned to be replaced in Alternative 1. Depending upon the project schedules, coordination will need to occur between both parties and design teams to ensure that the components selected will work for each project. This item will need to be evaluated in the next design phase, and incorporated into the future designs. The current

alternative includes conservative measures that would not substantially change the operations or connection point of the FCWWD18 project as it is currently planned, and thus, should have minimal impact on the FCWWD18 project.

For this project, a construction duration of 4-6 months is currently planned, though this may be extended based on unforeseen circumstances. It is anticipated that this work will be completed during the winter months, when temperatures at the FKC outlet works are low. This timeframe was chosen to permit FKC outlet water deliveries to the trout hatchery at temperatures that are within the range limits provided by CDFW. If this work cannot be completed during this timeframe, then alternate measures may need to be investigated that will provide water to the hatchery that fall within their required temperature range. It is highly improbable that late spring through early fall temperatures at the FKC outlet works would be adequate for this purpose, without special handling of the flows, including cooling the water to acceptable temperatures. Other scheduling conditions need to be confirmed, including coordination with the OCID power generation facility during the tee installation off-line period. This outage period will need to be scheduled, so that alternate water sources (temporary pumping as listed above) may be arranged for the hatchery. Additionally, the temporary loss of power generation at the OCID facility should be noted and coordinated to avoid any related issues. These items should be evaluated and completed if this alternative is selected as the preferred alternative for this project.

Due to the lengths of pipeline and structural construction, site dust abatement was considered in this study. The purpose of this dust abatement is to maintain the construction access, as well as reduce the airborne dust and debris caused by heavy construction. Additionally, construction projects in the Central Valley region of California must meet air quality requirements, and dust abatement is one of the primary methods used to meet these requirements. For this project, it was assumed that the roadways and structures under construction would require a 1/8-inch layer of water applied to their full width, three times per day. A total construction timeframe of 4 months was used to determine the required volume of water for dust abatement. The source of water to be used in dust abatement was not identified in this study, and is left as a future study item, should this alternative be selected.

C. Alternative 2 – Groundwater Wells

The design basis and intent of this alternative is to deliver water from a groundwater well field located between the town of Friant, CA and Clovis/Fresno, CA to the new SCARF facility. This will be accomplished by collecting smaller flows from a series of wells into manifold pipes, which will be routed into a booster pumping plant and forebay tank. The forebay tank will collect and buffer the inflow rates from the individual wells, and provide a necessary head for the booster pumps to operate. These booster pumps will lift water from this forebay tank, delivering it approximately 1.25 miles along N Friant Road and into a proposed storage tank at the new SCARF facility. Similar to Alternative 1, there are a number of legal and technical challenges to be overcome when designing this alternative. It is believed that, while the designs were only completed to an Appraisal level, the alternative proposed is both technically and legally possible. It is also believed that this alternative design could be constructed and implemented after final designs are completed.

The flow routing for this alternative requires a new groundwater allocation of 20 cfs taken from a

series of groundwater wells in a well field located between the town of Friant, CA and Clovis, CA. Based on preliminary groundwater models, and using data taken from existing nearby wells, it was determined that a minimum of 60 wells would be required to supply 20 cfs. Because of the requirement to have a constant 20 cfs to the SCARF, an additional 12 wells (20%) were added, which brings the total well count to 72. It is not anticipated that every well will be in operation full-time, but rather that the minimum quantity would be operating, with alternate wells being activated as required. Each well location will be connected to a well-string pipeline via a 6-inch diameter high density polyethylene (HDPE) line, approximately 25 feet long. Each well-string pipeline is sized to vary from 6-inch diameter to 16-inch diameter, to accommodate the addition of flows from each successive well. As shown on the Proposed Site Plan in Appendix B, there are five well-string pipelines proposed, which all connect to the main manifold pipeline. This main manifold pipeline will be an HDPE pipe that varies from 16-inch to 30-inch diameter. The manifold pipe will terminate in an underground reinforced concrete storage tank, called the forebay tank, which serves as a clearwell and forebay for the booster pumping plant pumps. This storage tank also serves to regulate the variable flows from the individual well pumps. From this point, a single booster pump (with standby pump for redundancy and O&M reasons) will lift the 20 cfs flows from the underground tank into a 30-inch diameter HDPE delivery pipe. This pipe runs for approximately 6,600 feet to the SCARF. It is anticipated that a storage tank will be added during the SCARF construction, and that the 20 cfs flows will be routed into the tank. To accommodate an above-ground storage tank, an additional 10 foot of head lift was added to the booster pump capability. This storage tank will serve as the delivery demarcation point identified for this study. At this point, it is assumed that the flows would be routed by CDFW as needed to support the SCARF. No details or estimates for this routing of flows at the SCARF are included in this study.

This alternative has a series of civil, mechanical, electrical, and SCADA features that were designed during the development of this study. Each of these features is detailed below.

Civil Items:

The primary civil features of this alternative are the groundwater wells, well drill pad sites, access roads, conveyance pipelines, related earth work, the reinforced concrete storage tank, the booster pumping plant, and the recommended storage tank at the SCARF. Each of these features is discussed in detail below.

This first major civil feature of this alternative proposes to install 72 groundwater wells, to a depth of approximately 700 ft. As discussed above, there are 72 wells to provide for the redundancy required to deliver a constant 20 cfs supply to the SCARF.

The following assumptions were used to develop the well quantities for this alternative:

1. Total flow to hatchery = 20 cfs, constant 24/7 demand
2. Back-up/redundancy factor = 20% of capacity
3. Average well yield of 150 gpm (see Note 1)
4. Total demand of 20 cfs = approximately 9000 gpm, which was divided by 150 gpm per well giving a well count of 60 wells

5. 60 wells plus a 20% back-up/redundancy safety factor = 72 wells
6. Aquifer is fractured granite – average Transmissivity is 0.053 ft²/s (see Note 2)
7. Average Storativity is 0.0000018 per foot (see Note 2)
8. Average equivalent porosity is 0.065 (6.5 %) (see Note 2)
9. Radius of Influence is based on Bear's (1979) equation: (see Note 3)

$$R(t) = 1.5(TtS)^{1/2}$$
 where T = transmissivity, t = time, and S = storage coefficient (storativity)

Note 1: The average well yield was based on well logs and reports provided by Fresno and Madera counties.

Note 2: Assumptions 6, 7, and 8 are based a compilation of hundreds of reported measured values for material properties.

Note 3: Using the equation shown in Item 9 above, where t = 365 days (in seconds), R is calculated as approximately 249,000 feet. This method is identified as Option 1 in this report.

Zero-Drawdown Option Details:

The 249,000 foot radius of influence for each individual well would be an extreme condition where the drawdown is effectively zero. In reality, the drawdown may be on the order of an inch at a distance considerably closer to the well, which would dramatically reduce the required radius.

It is expected that the deep granite aquifer would likely be confined or semi confined. The aquifers' primary porosity would be low and the secondary porosity (from cracks, fractures, and weathering) would be highly variable. Each site is unique, but an estimated well spacing of 2,000 feet between wells (1,000 foot radius) is a reasonable starting point, based on the well reports from the area. Thus, this Alternative would consist of 7+ wells per square mile, requiring approximately 11 square miles for all 72 wells in the well field.

Pumped Drawdown Option Details:

There is a second way to calculate radius (R) that takes into account the pumping rate and can calculate the drawdown at various distances from the pumping location. Details of this method, and the calculations for it, are listed below and are identified as Option 2 in this report.

This option uses the following assumptions:

- The Transmissivity (0.053 ft²/s) and Storativity (0.0000018 per foot) values are the same
- Assuming a range of maximum allowable drawdown in an average well
- Assuming a 16-inch diameter well

Maximum Drawdown*	Calculated Drawdown**	Sustained Yield		Radius of 1' drawdown***
		Maximum	Optimum	
(feet)	(feet)	(gpm)	(gpm)	(feet)
10	5	115	77	1,012
20	10	230	154	3,736
30	15	346	232	6,348
40	21	462	309	8,584
50	26	577	387	10,580
60	31	692	464	12,340

* Maximum allowable drawdown in well – should not exceed 50% of the saturated thickness or 50% of the distance between the Static Water Level (SWL) and the pump intake, whichever is less. As long as this value is greater than or equal to the calculated drawdown value, then this figure does not constitute a limiting factor.

** The calculated drawdown in the pumping well at the Optimum Sustained Yield pumping rate for the T & S values of 0.053 and 0.0000018 respectively. This value should realistically be less than 50% of the saturated thickness or less than 50% of the distance between the SWL and the pump intake, whichever is less.

*** The radius at which the measurable drawdown in a fictitious observation well would be 1.0'. This is important because the drawdown at any point between two or more pumping wells is the sum of calculated drawdown from each pumping well that the point is within the maximum radius of influence for that well.

From the above table, it can be seen that the well construction can influence the well's capacity almost as much as the aquifer properties. Thus, the original assumption of a well yielding 150 gpm may be overly conservative. The example well that the assumption was based upon may be the limiting factor in the capacity of the design well, as opposed to the aquifer properties being the limiting factor.

To determine where the limiting factors for well design are (either the example well used or the aquifer properties) will require a more detailed and site specific study. It will then be possible to optimize the proposed well design to take full advantage of the aquifer properties. This may result in a well capacity greater than the 150 gpm proposed, which would result in fewer wells being required. Further design data would be required prior to final design of this alternative.

Both Option Details:

Regardless of the method to calculate the radius of influence shown above, each drill site would need a drill pad, drill rig, support vehicles, material staging, etc. Each well would need a place to discharge the water extracted during development and testing. Additionally, each well would need the required discharge permits. Temporary power would need to be provided to each well site, usually in the form of a portable generator, for testing. Permanent power would then be installed after the permanent pump and controls are installed.

It is not advisable to locate the well field to the North, Northeast, or East of Friant, CA. These

locations have geology that consists of schist, instead of the granite found to the West and South of Friant, CA. This change in geology would significantly modify the proposed well designs shown above. Additionally, these locations would have a different aquifer state, and the well logs and reports used for design would no longer be applicable.

To provide a staging area and site access for the well drilling rig and associated support vehicles, a series of 72 temporary drill pad sites will be created. These temporary drilling pads are a cleared section of land that measures 50 feet by 75 feet. These pads will have the topsoil removed to a depth of approximately 6 inches, and this material will be stockpiled for later site restoration. The remaining ground surface will be used as the temporary staging area for the drill rig, bits and steels, well casing pipes, miscellaneous well materials, and other support vehicles. After the well has been drilled, prepared, and tested for operation, the drilling rig and support vehicles will mobilize to the next site. The material that is removed from the drill hole will be collected and hauled to an approved disposal/spoil site, approximately 15 miles one-way from the site. The temporary drill pad will be reduced in size from 50 feet by 75 feet to 20 feet x 20 feet, to constitute the permanent well site. The previously stripped material that was stockpiled will be used to restore the sites. The permanent well site will require permanent O&M access. For this study, it was assumed that each permanent well site would require a 10 foot tall (8 feet of chain-link and 2 feet of barbed wire) fence surrounding the well, with a locked gate for O&M access. This was included for possible vandalism reasons, and to keep the general public from accessing these sites. If this security is deemed unnecessary, these costs could be deducted.

To provide access to the drill pads and well sites, a series of roads will be created. These roads will follow the approximate alignment of the well-string and manifold pipelines, but will be offset about 25 feet to allow for the pipe trench construction to occur without disturbing the roadways. The proposed access road will intersect with North Friant Road, which will serve as the primary access point to the well O&M roads. The access roads will also intersect with other local roads (Auberry Road, Biglione Drive, etc.), and are proposed to be constructed as 4-way intersections with stop signs. These designs have not been completed at this level, and are left to future studies if this alternative is selected as the preferred alternative. Similarly, the exact route and alignment of the access roadways has not been determined at this level, but can be designed in future studies if this alternative is selected as the preferred alternative. No estimates have been included in this study for these roadways.

The next major features of this alternative are the well conveyance pipelines, which run from the individual groundwater wells, through the well-string pipes and manifold pipes, and into the storage tank. As noted above, all of these pipes will be constructed from HDPE PE 3408 material, suitable for use with the pressures anticipated in this system. These pipes vary in diameter from 6-inches to 30-inches. All of these pipes will have a dimension ratio (DR) of DR 17, which was selected to support working pressures of 100 psi. Hydraulic calculations for these pipes were conducted using Microsoft Excel. The analysis was completed in accordance with TSC Design Standards Number 3, Chapter 11: General Hydraulic Considerations, 1994 and American Water Works Association (AWWA) M55, Polyethylene (PE) Pipe – Design and Installation. The proposed HDPE pipeline would not require additional coatings or linings to resist corrosion and environmental effects.

The new HDPE pipelines will connect directly to the groundwater well pump discharge lines,

downstream of the backflow preventing valve. The pipelines will be connected to the well-string pipes, and those to the manifold pipelines using butt fusion welds. The manifold pipe will be terminated at the storage tank using a flanged-through-wall connection. These pipes will be run as shown on the Proposed Site Plan in Appendix B. The pipes will be located in a Type 2 trench constructed for this alternative. This pipe trench would have a 4-inch uncompacted bedding. A native embedment material will be placed and compacted over the bedding to a height of 6 inches over the crown for pipes less than 12 inches in diameter, or to 0.7 of the outside diameter for pipes greater than 12 inches in diameter. The remainder of the pipe trench will have uncompacted earth fill to the original grade elevation. In locations under roadways or other vehicle areas, the backfill would be fully compacted. Reinforced concrete thrust blocks were not included in this design due to the low velocities anticipated in these pipelines. This assumption should be evaluated at the next design phase if this alternative is selected.

A secondary pipeline is required for this alternative, which is called the delivery pipeline. This pipeline is to be a 30-inch diameter, HDPE pipe. This pipe is different from the above pipes in that it will have a smaller dimension ratio of DR 26, which can safely handle working pressures up to 64 psi. This pipe will be located entirely underground, and will be placed in a pipe trench similar to the 30-inch manifold pipe above. This pipe will start at the discharge side of the booster pumping plant manifold line, and run to the recommended storage tank at the SCARF. The isolation valve and other mechanical features for this pipeline will be contained within the booster pumping plant manifold line, and is explained further in the Mechanical Section for this alternative. The proposed SCADA controls for this booster pumping plant and associated mechanical features is explained further in the SCADA Section for this alternative.

The earth work for both pipes is similar in design, and is a Type 2 trench matching TSC design standards. This trench type and details can be found on USBR drawing 40-D-6551, shown as Appendix D. The typical trench section is proposed to be excavated to a varying total depth of 6 to 8 feet. The 6 to 8 foot depth was chosen to account for the varied topography and different diameters present in this pipeline layout. The trench was designed to include an uncompacted bedding depth of 4 inches under the invert of the pipe, which provides for proper support. Since the pipe is designed to be HDPE, it is considered a flexible pipe material. Therefore, a native embedment material will be placed and compacted from the invert elevation above the uncompacted bedding to a height of 0.7 of the outside diameter. This embedment material is chosen to transfer the loading on the pipe from the HDPE into the walls of the trench. For this design, a soil E' value of 1,000 pounds per square foot (psf) was chosen, based on the limited geotechnical information at this site. This soil pressure is assumed to be adequate for weak soils, containing fine silts and sands, or other non-load bearing soils. This geology matches other sedimentary soils found near this site, along the SJR. The trench bottom width was chosen to provide at least one outside diameter clearance at the pipe springline. A two horizontal to one vertical slope was chosen for excavation, based on the short duration of the construction work and the angle of repose of the anticipated soils to be present. The embedment around the pipe will be compacted to a minimum 95% relative compaction (standard Proctor), similar to other USBR pipe projects. All fill placed above the compacted embedment will be set in lifts, with no testing or compaction requirements. No vehicle loading will be allowed until there is a minimum of 3 feet of fill over the pipe. The top layer of backfill will be replaced using the material stripped previously. No groundwater is assumed to occur that requires site dewatering in the pipe trenches, based on the low water table and invert elevation of the trenches. However, it is

anticipated that site unwatering will be required to remove precipitation and other inflows into the excavated trenches. The required unwatering is discussed below in the Other Items Section, which includes both the storage tank areas and the pipe trench areas.

This alternative includes a reinforced concrete storage tank, which serves two purposes. The first is to buffer the variable flows from the numerous groundwater well pumps that will ultimately reach the SCARF. Each well is anticipated to produce approximately 150 gpm, which is approximately equal to 0.334 cfs, which will be collected and conveyed through the well-string and manifold pipes to the storage tank. Because each well will not produce exactly the volume of water specified, nor will every well be online and delivering water at the same time, the inflow of water to the booster pumps will vary. To regulate these flows, the storage tank will buffer the variable capacity production of the wells. Additionally, the tank will buffer out any wells going offline (O&M or emergency reasons) and being replaced by another well coming online. The second function of the tank is to act as a clearwell for the booster pumps, which require a suction head to operate. By capturing the flows in a tank, the booster pumps can be mounted such that there is always an available water surface to provide the necessary suction head.

The dimensions of the tank were sized to provide for approximately 4 hours of storage time, based on a delivery flow of 20 cfs. Four hours was chosen as a minimal storage time for CDFW staff (or others) to respond to a SCADA alarm generated at either the booster pumping plant or the SCARF. This alarm would indicate a failure of the system to pump, convey, or deliver water to the SCARF. The four hour timeframe was chosen based on two primary factors: the proximity of the storage tank and booster pumping plant to the CDFW facility (~1.25 miles), and that the CDFW facility maintains a manned 24/7 presence at their facility. Based on an approximate four hour storage time, the tank was sized to be 150 feet long by 150 feet wide. The tank is proposed to be located underground, with the top deck being located at the ground surface. This placement was chosen for two primary reasons. First, this placement would provide for better aesthetics, as the tank would not be a visual obstruction in the landscape. Second, it would set the tank water surface elevation range at a level which allows the well pumps to deliver water directly, without the need for larger pumps or additional booster pump units. Based on a four hour storage timeframe, the required depth of the tank was found to be 20 feet. Because the top deck of the tank would be set at ground level, a 2 foot thick slab and roof deck were included. To support the roof deck, a series of columns would be located inside the tank, and spaced at 15 feet on center. These columns would be reinforced concrete, and would be 2 feet by 2 feet square and 20 feet tall. These columns would be connected to both the slab and roof deck. Though supported by columns, it is not anticipated that the roof deck would support vehicle loads. Instead, the roof deck was designed to support personnel loading, and part of the booster pump weight. The remainder of the booster pump weight is anticipated to be supported by a slab on grade, adjacent to the storage tank. The walls of the tank were preliminarily designed to accommodate the soil loading at a total depth of 24 feet, as well as the miscellaneous live loads, seismic loads, hydrostatic and hydrodynamic loads, and other standard loading cases. It is proposed that this tank be constructed of reinforced concrete, using reinforcing steel with yield strength of 60,000 psi, and concrete with a compressive strength of 4,500 psi as per American Concrete Institute (ACI) 350-06 and USBR Design Standards. The proposed storage tank will have two access ladders, equipped with safety cages for fall protection. These ladders will be mounted to the walls, at opposite corners of the tank. The

ladders will be covered at the deck using an aluminum access hatch, which has a 3 foot x 3 foot opening. These hatches were sized to accommodate both personnel and small equipment access.

The site of the booster pumping plant and storage tank will be located adjacent to the access roads above, as shown on the Proposed Site Plan in Appendix B. This will provide for construction access to the site, as well as permanent O&M access to the booster pumping plant and storage tank. Similar to the well sites above, the storage tank and booster pumping plant will have a 10 foot tall fence (8 feet of chain-link and 2 feet of barbed wire) that surrounds the site. A locking access gate will be installed at the roadway to provide for O&M access. To prevent vehicles from driving onto, or parking on, the deck, a series of bollards will be placed around the perimeter of the tank, at 10 foot centers. These bollards will be filled with concrete to prevent accidental damage or removal. To construct the tank an excavation area will be dug that is 5 feet larger horizontally than the tank dimensions. The excavation will be dug to a depth of 25 feet, to allow for compaction of the tank foundation and for the tank height. After the floor slab, walls, and deck are constructed, structural backfill will be placed and compacted back to the original grade elevation. The booster pumping plant is proposed to be located along the northwest corner of the storage tank, and the plant details are listed below.

The booster pumping plant will be located adjacent to the storage tank, as shown on the Proposed Site Plan in Appendix B. The booster pumping plant will consist of two pumps, one in operation and one in standby mode. The second pump has been added for redundancy, based on the requirement for a constant 20 cfs supply to the SCARF. The booster pumps will be vertical shaft pumps, which lift water out of the storage tank and into the delivery pipeline. Fixed speed pumps were used for the booster pumping plant. It is anticipated that the recommended storage tank at the SCARF will be approximately 10 feet above the ground surface. This additional elevation head was included in the booster pump sizing calculations. It is anticipated that the booster pumps will be located outdoors, and will operate in that outdoor environment. A small structure may be erected to cover the pumps, but no building is proposed at this time. If this alternative is selected as the preferred alternative, a building to enclose the pumps may be considered. The booster plant will include provisions for a SCADA system (operating in a data acquisition mode only) that will monitor the pumps and flow from the plant. If the flow drops below 20 cfs, or the pump shuts off, a SCADA alarm will be issued to the CDFW facility for O&M personnel to respond to. With the standby pump in-place, the responding personnel have the ability to switch valving over to the new pump, start the pump, and resume delivery of flows to the SCARF. The expected response times, as well as the need for a constant 20 cfs flow to the SCARF, are the primary reasons for recommending a storage tank at the SCARF. Additional details about the pumps may be found in the Mechanical section below.

As identified above, this study recommends a storage tank be included at the SCARF. The size, location, and cost estimate of this tank were not developed, as this item was beyond the scope of the study. However, during the design process, it was determined that a storage tank at the SCARF would be highly recommended to provide flexibility and redundancy of operations. Additionally, if any maintenance or emergency situation were to occur that required a temporary shutdown of flows, the storage tank could provide a source of flows during this outage timeframe. For these reasons, this study recommends that a storage tank be evaluated during future designs, and the tank included at the SCARF for this alternative. No costs were included for this recommended storage tank in this study because it would be designed and purchased by

CDFW, and it would be located on CDFW property.

Mechanical Items:

A Booster Pump Station is required at the storage tank to lift the collected groundwater to the Fish Hatchery. Two vertical turbine mixed-flow pumps (1 + 1 installed spare) provide the 20 cfs flow required to be delivered to the hatchery. A redundant pump is installed to maintain system reliability. The pumps are each rated at 20.6 cfs (with 3% wear factor) and 35 feet TDH (Total Dynamic Head). Each pumping unit is powered by a 125-hp, TEFC (Totally-Enclosed, Fan-Cooled), vertical induction electric motor operating at 900 rev/min, 460 volts/3 phase/60 hertz.

The 20 cfs pumping plant will include two 20-inch steel pipe discharge lines. These two lines will manifold into one 24-inch steel pipe downstream. These lines were sized for approx. 5 feet per second water velocity. Each pump discharge will include a throttling air valve, combination air valve, check valve, and butterfly valve. The air valve just downstream of the pump will be the type designed for vertical turbine pump service. This type of air valve gives controlled discharge of air upon pump start-up and prevents large volume of air entering the discharge piping in order to protect against surge. It also admits air during pump shut-off for breaking vacuum in order to protect the pump and mechanical seals. Further downstream on each pump discharge line will be a combination air valve which allows air out during pipe filling, allows air in during pipe draining, and releases small amounts of air that otherwise would be entrapped during operation. The check valve prevents reverse flow through the pump. The butterfly valve will open during pump startup so that the pump is always pumping against head. Pipe supports and pipe couplings will be provided where needed for anchoring of the pipe and also to allow flexibility in the system and removal of valves for maintenance.

Electrical Items:

Motor Bus Voltage Selection

Motor bus voltage selection is based on the maximum horsepower of individual pump motors and the total kilovolt-ampere (kVA) load of each pumping station. The 72 well sites each have a single 30 horsepower pump motor. The booster pumping station has two 125 horsepower pump motors. The motor bus voltage for each well site and the booster pumping station is 480 volts, 3-phase.

Motor Selection

All pump motors are single-speed, premium efficiency, squirrel-cage induction type. The motor enclosures are totally-enclosed, fan cooled (TEFC) and suitable for outdoor operation.

Motor Starting

Motors are started full-voltage, across-the-line with magnetic motor contactors. All motor contactors are housed in NEMA Type 4 combination starter enclosures and suitable for outdoor operation.

Power Distribution

For estimating purposes, it was assumed the high-volt power distribution system would be furnished by the local utility authority.

The 72 well sites are arranged in a grid pattern. The separation between sites is approximately

2,000 feet. Groups of 2, 3, or 4 pump motors are provided with 480 volt, 3-phase power from a single pole-mounted step-down transformer. The booster pumping station is provided power from a pad-mounted step-down transformer.

SCADA Items:

The SCADA system will communicate with the booster site and well sites via unlicensed spread-spectrum radio. A radio at the fish hatchery will send a demand start/stop signal to the radio at the booster pumping plant. The active booster pump will start or stop based upon this signal. The radio at the booster plant will provide the fish hatchery with flow rate, vault level and pump status information for indication and alarm.

Two high level alarms will be set at the booster plant. Upon a pre-determined high level in the vault, the active booster pump will start to allow the vault to be pumped down. A second pre-determined high level, higher than the first, will send a stop signal to the well sites.

Other Items:

For this project, construction duration of 6-12 months is currently planned, though this may be extended based on unforeseen constraints. The schedule for this construction is not critical to any other USBR or CDFW operations, as the SCARF facility will be hydraulically separated from the CDFW hatchery flows under this alternative. For this reason, it is anticipated that the construction would occur as soon as permitting, land acquisition, and other preliminary actions were completed. Due to the large number of wells in this alternative, the overall construction timeframe is expected to be longer than that of Alternative 1. Additionally, the storage tank and booster pumping plant will need to be constructed concurrent with the well and pipeline items. As these items are in separate locations, and are exclusive of one another, their construction can be scheduled in parallel. Thus, the overall construction timeframe of 6-12 months can be achieved.

A critical item to consider for this alternative is the large number of wells and access sites that need to be obtained and maintained throughout the project life. As shown on the Proposed Site Plan, the well field would extend from the southern edge of Friant, CA to the northern limits of Clovis, CA. The anticipated required area for the well field is approximately 11 square miles, with the wells spaced at a minimum of 2,000 feet. This spacing is required to maintain the delivery capacity of each well, and ensure that there is sufficient groundwater to supply the well throughout the project lifespan. The groundwater data, as noted above, is based on various county and California Department of Water Resources (CDWR) records and wells located in the vicinity of the project. This preliminary data used for this analysis is not considered to provide a complete understanding of the groundwater availability at the project site. Further analysis, including site investigations, should be completed during future studies to refine the groundwater understanding and well capacities in the area, if this alternative is selected for further development.

This alternative includes a large area of ground disturbance as a result of the construction of the roadways, storage tank, booster pumping plant, and the well pipelines. Based on the groundwater elevations found during the well investigation and design, dewatering of the construction areas is assumed to not be required. However, as the construction is expected to last between 6 and 12 months, unwatering of the excavations is assumed to be required. For this

study, a base storm event was chosen, and applied as the rainfall event expected to occur during construction at each site (storage tank/pumping plant and well pipelines). The storm event selected as the design basis was a 12-hour event occurring every two years. The 12-hour event was selected as the most likely event to occur during a single work shift/day, and that which could not be predicted and planned for. It is assumed that any larger storm event could be predicted in advance, and site precautions would be taken to avoid risk to life, loss of construction work, or other property damage. The two year recurrence period was selected based on the anticipated construction duration of 6-12 months, which could be scheduled to span over two wet seasons (e.g. October, 2015 to October, 2016). From the selected storm event and recurrence period, NOAA rainfall curves were used to determine the expected rainfall intensity. This intensity value was then applied over to the anticipated open area, which was assumed to be the full area for the storage tank, and a 200 foot length of open trench for the pipelines. To be conservative, the run-off coefficient of 1.0 was applied, which requires the entire precipitation volume to be handled by the unwatering pumps. Based on these input values and project assumptions, a series of (4) 50 gpm pumps were selected to handle the required unwatering of the excavations. It is expected that two sets of pumps will be required to complete the construction, with one at the storage tank site, and the other moving with the well pipelines as required.

Due to the large lengths of pipeline and roadway construction, site dust abatement was considered in this study. The purpose of this dust abatement is to maintain the construction roadways, as well as reduce the airborne dust and debris caused by heavy construction. Additionally, construction projects in the Central Valley region of California must meet air quality requirements, and dust abatement is one of the primary methods used to achieve this requirement. For this project, it was assumed that the roadways under construction would require a 1/8-inch layer of water applied to their full width, three times per day. A production rate of 1,162 feet per day was assumed for the roadway work, which resulted in 261 total days of construction. The source of water to be used in dust abatement was not identified in this study, and is left as a future study item, should this alternative be selected.

IV. FINDINGS

The results of this study are presented below, including construction cost estimates for each alternative (including a note regarding adding in Real Estate costs), a set of construction schedules, recommendations for future studies, and study conclusions.

A. Construction Cost Estimates

Origin and Source of the Cost Estimates

Designs and quantity estimate worksheets were developed by the various TSC design groups (Water Conveyance, Mechanical, Electrical, SCADA, etc.), and given to the Estimating, Specifications, and Construction Management group (86-68170) of the TSC for construction cost estimating. The estimates are in accordance with Reclamation Manual Directives and Standards FAC 09-01 and FAC 09-03.

Purpose and Intended Use of the Cost Estimates

For each of the alternatives, appraisal level field cost estimates were prepared. Due to the early

project stage and limited design data there is insufficient confidence at this stage to determine project budgets.

Appraisal Cost Estimates – Basic Scope

Appraisal level cost estimates are used in Appraisal level reports to determine whether more detailed investigations of a potential project are justified. These estimates are also intended to be used as an aid in selecting the most economical plan by comparing alternatives features. These estimates were developed from approximate quantities and existing data, and preliminary general designs and drawings.

The estimates generated the following major costs: Contract Cost and Field Cost. Contract Cost is the term used for the Subtotal of project feature costs, with mobilization and Design Contingencies (previously Unlisted Items) added. Field Cost is the term used for the total of Contract Costs and Construction Contingencies added. Total Field Cost is the term used for the total of Field Cost and Non-Contract costs, which are the design, data collection, permitting, approval, and other related costs not associated with the design of the project. Non-Contract Costs and the subsequent Construction Costs are to be determined by the appropriate responsible office (MP-170). Applicable contingencies were applied and are described in more detail in separate sections below.

Appraisal level cost estimates are not suitable for requesting project authorization or construction fund appropriations from Congress due to the early stages of project development.

Basis of Cost Estimate

The unit prices are based on historical, bid, and industry reference costing data. In some instances unit prices were developed from modeling labor, crew size equipment, material, and productions rates. Quotes for various materials were obtained as deemed necessary by the cost estimator.

Price Level

All costs are in October 2012 dollars.

Mobilization

A value of + 5% was utilized for mobilization. Mobilization costs include mobilizing contractor personnel and equipment to the project site during initial project start-up. The assumed + 5% value in the cost estimates are based upon past experience of similar projects.

Escalations

An allowance for escalation from the October 2012 price level to the assumed Notice to Proceed date of October 2015 is included in the estimates. Note that the escalated costs are Field Costs and do not included Non-Contract Costs that generate the Construction Costs.

Design Contingency

A value of + 15% was utilized for design contingencies based upon the completeness of the specified tasks. Design contingencies are intended to account for three types of uncertainties inherent as a project advances from the planning stage through final design which directly affects the estimate cost of the project. These include minor unlisted items, minor design and scope changes, and minor cost estimating refinements.

Allowance for Procurement Strategies

An Allowance for Procurement Strategies (APS) of + 5% is included in the cost estimates. This allowance accounts for additional costs when solicitations may be advertised and awarded under other than full and open competition. These include solicitations that will be set aside under socio-economic programs, along with solicitations that may limit competition or allow award to other than the lowest bid or proposal.

These estimates assume request for proposal acquisition with award to the lowest responsive and responsible bidder.

Construction Contingency

A value of + 25% was utilized for construction contingencies based upon the completeness and reliability of the engineering design data provided, geological information, projected quantities and the general knowledge of the conditions at the site.

Appraisal estimates include a percentage allowance for construction contingencies as a separate item to cover minor differences in actual and estimated quantities, unforeseeable difficulties at the site, variable site conditions, possible minor changes in plans, and other uncertainties. The allowance is based on engineering judgment of the major pay items in the estimate, reliability of the data, adequacy of the projected quantities, and general knowledge of the site conditions.

Non-Contract Costs

No allowance is included in the cost estimates for non-contract costs. Non-contract costs typically include but are not limited to environmental mitigation and restoration, cultural resource preservation, service facilities (camps, construction roads, utility systems, temporary plants used for construction, etc.), planning investigations (studies, permits, and surveys), engineering and other costs (design and specifications, construction engineering and management, general office salaries, supplies and expenses, general transportation expenses, security, environmental oversight, legal services, land acquisition, relocation of property, etc.

All cost estimate worksheets can be found in Appendix C.

Alternative 1 (Piping):

The total Field Cost of Alternative 1 is \$1,800,000.00. As mentioned above, this option has a non-quantified monetary risk associated with temporarily suspending flows, and using a temporary pump to supply water to the CDFW hatchery. This risk should be considered during the determination of which alternative shall be selected as the preferred option for this project.

Alternative 2 (Groundwater Wells):

The total Field Cost of Alternative 2 is \$100,000,000.00. As mentioned above, this option has a non-quantified monetary risk associated with the land acquisition and permitting required for the groundwater wells and storage tank/booster pumping plant. Additionally, it has the risk associated with the actual well production flow values that can be obtained. These risks should be considered during the determination of which alternative shall be selected as the preferred option for this project.

B. Real Estate Costs

Due to the local variability of real estate costs, the Estimating, Specifications, and Construction Management group of TSC (86-68170) does not provide costs for real estate acquisition or fees. The cost of lands for each alternative will need to be determined by the Regional (Mid-Pacific Regional Office) or Program Office (SJRRP Office) real estate team, and added to the overall construction costs listed above. It is expected that the costs for Alternative 2 would be significant due to the anticipated size of the well field.

C. Actions for Future Studies

As noted throughout this report, there are a series of actions that should be completed in future studies and designs, based upon which alternative is selected as the preferred option for this project. A summary of these recommendations is listed below for future reference:

1. A complete series of site investigations should be completed based upon the alternative that is selected as the preferred option. This site investigation series should encompass all of the civil, geotechnical, geological, electrical, SCADA, and mechanical components of the existing project site. After these items have been examined and investigated, and the necessary design data could be collected via the Design Data Request and Field Exploration Request processes. Following this step, the Feasibility and Final Design processes can be used to determine how the proposed alternatives will be integrated to produce the desired project goals and objectives.
2. The required permitting actions for both the site investigations and construction should be investigated, and the appropriate schedule and effort planned for. These permitting actions can have significant schedule implications, and should be taken into account when choosing an alternative. Similarly, the actions for Alternative 2 – Groundwater Wells may require substantial effort to obtain the required groundwater rights and permits. This effort should be determined, if this alternative is selected, and the necessary schedule and resources allocated to prevent delays.
3. The required land acquisitions for either alternative will require future study to determine accurate sizes, costs, and timeframes. Depending upon which alternative is selected, the appropriate land acquisition values and schedule should be developed in partnership with the Regional or Area Office real estate personnel. These values should be added to the total project cost as appropriate.
4. There are currently a number of other potential projects being studied at the Friant Dam site, as well as the construction of the SCARF. During future design work, coordination with all parties should be maintained to ensure that there are not conflicts between projects.
5. As noted above, part of the design for Alternative 1 may have implications that would require a Safety of Dams review. If this alternative is selected as preferred, then the necessary actions should be taken to accommodate this review.
6. For Alternative 1, it may be possible to replace the PRV arrangement shown, in the future, with a turbine-generator set for hydroelectric power generation. This option was not included in the design of this Alternative, and is left as a future study item.

7. As mentioned above in Alternative 1, the source and permitting for the temporary pumped water supply was not refined in this study. If this alternative is selected, contracts, permits, and/or agreements would likely be needed to avoid construction problems.

8. Finally, as note above in Alternative 2, the exact state of the groundwater in the region is not fully understood. The calculated well capacities used for this study were taken from rough groundwater maps of the area, and combined with the local well data that was publicly available. Based on the investigations mentioned above, a complete groundwater and well capabilities analysis should be completed to confirm the rates used for this study. This analysis should be incorporated in pilot well program, used to determine actual aquifer capabilities and well details. If variations from this studies results are found, then the appropriate modifications should be made to both the size, depth, number, and spacing of wells, such that the required 20 cfs can be delivered to the SCARF.

9. An analysis should be conducted to determine the appropriate pipe size if other parties (FCWWD18) are going to use the pipe system described in Alternative 1.

D. Project Recommendations

During the development of this study, a number of project opportunities arose that were not included in these two Appraisal designs. These items were developed to a preliminary level, and are listed here for consideration in the project at a later date.

First, it was determined that an improvement could be made over the current lack of storage conditions at the CDFW facility. The exact size, construction, details and nature of the storage facility were not calculated for this study. It is recommended, however, that a storage facility with a capacity of at least 3 hours be considered in the future plans for this site, if the full 55 cfs flow is to be stored (35 cfs for the trout hatchery and 20 cfs for the SCARF). The 3 hour value was determined based on the volume of flows entering the hatchery, the response time of USBR and CDFW personnel, and the short travel distances involved for this project. A 3 hour storage tank would need to hold approximately 4.44 million gallons for 55 cfs flows or 1.62 million gallons for 20 cfs flows.

In conjunction with the other concurrent studies, the piping at Friant Dam could be modified for Alternative 1 to reduce velocities, thus reducing overall O&M costs and increasing the available head for power generation at the OCID facility.

For Alternative 1, the 20 cfs flows bypassing the OCID facility proposed to be routed into the PRV's could be revised to pass through a hydropower generating facility. This facility could be located over the existing PRV valve vault designed for Alternative 1, which is located adjacent to the existing OCID facility. This could be accomplished by removing the proposed Pressure Regulating Valves, and replacing them with a turbine-generator set. The new turbine-generator set electrical system could connect to the existing Pacific Gas & Electric facilities which are near the OCID facility. Using this system, additional hydroelectric power could be generated from the 20 cfs flows that would otherwise bypass the OCID facility.

If Alternative 2 is selected as the preferred alternative, then an on-site storage tank is recommended to store water for the SCARF. This tank would receive flows from the booster

pumping plant, which receives source water from the groundwater wells identified. No sizing for this tank has been done for this study.

E. Study Conclusions

Given the two alternatives analyzed in this study, it was found that either one is technically possible and could be constructed to meet the projects' objectives and goals. However, as noted above, both alternatives have risks associated with them. Through additional investigations and other actions noted above, these risks can be identified and mitigated.

Through this study, it was found that either alternative could be properly investigated, designed, and constructed within the required project schedule. This schedule would include the following milestones:

1. Selection of the Preferred Alternative by April, 2013 (Final Design begins)
2. Final Design, Spec D (90% complete) by October 1, 2013
3. Final Design, Spec B (100% complete, Bid Package ready) by December 1, 2013
4. Bidding/Procurement complete by May, 2014
5. Notice to Proceed issued by June, 2014
6. Construction complete, project on-line by Fall, 2015

As noted above, there are a series of preliminary actions that would be required to support the proposed schedule. These actions would need to be accomplished within their respective listed times to maintain the overall project schedule. A delay in any step of this process could jeopardize the overall project schedule.

Finally, from the Field Cost aspect, it was found through this study that Alternative 1 has a Field Cost savings of \$98,200,000.00 over the other alternative. It should be noted that the Field Cost provided is not the total project cost (**e.g. Real Estate, Permitting, Non-Contract costs, etc. are not included**). Additionally, this project has other risks that may influence the selection of a preferred alternative, and these should be evaluated during the decision making process.

V. REFERENCES & APPENDICES

A. REFERENCES

- [1] “Treatment Report and Calculations” Ron LeBlanc, et al, United States Bureau of Reclamation Technical Service Center (86-68120), July 2012.
- [2] “Design Standards No. 3, Chapter 11 – General Hydraulic Considerations”, United States Department of the Interior, Bureau of Reclamation, Technical Service Center, Denver, Colorado, 1994.
- [3] “Design Standards No. 3, Chapter 12 – General Structural Considerations”, United States Department of the Interior, Bureau of Reclamation, Technical Service Center, Denver, Colorado, 1994.
- [4] “Reclamation Safety and Health Standards”, United States Department of the Interior, Bureau of Reclamation, Safety and Occupational Health Office, Denver, Colorado, 2001.
- [5] “Code Requirements for Environmental Engineering Concrete Structures and Commentary (ACI 350-06)”, American Concrete Institute, Farmington Hills, Michigan, 2006.
- [6] “PE Pipe – Design and Installation (M55)”, First Edition, American Water Works Association, Denver, Colorado, 2006.

B. APPENDIX B – Figures and Drawings

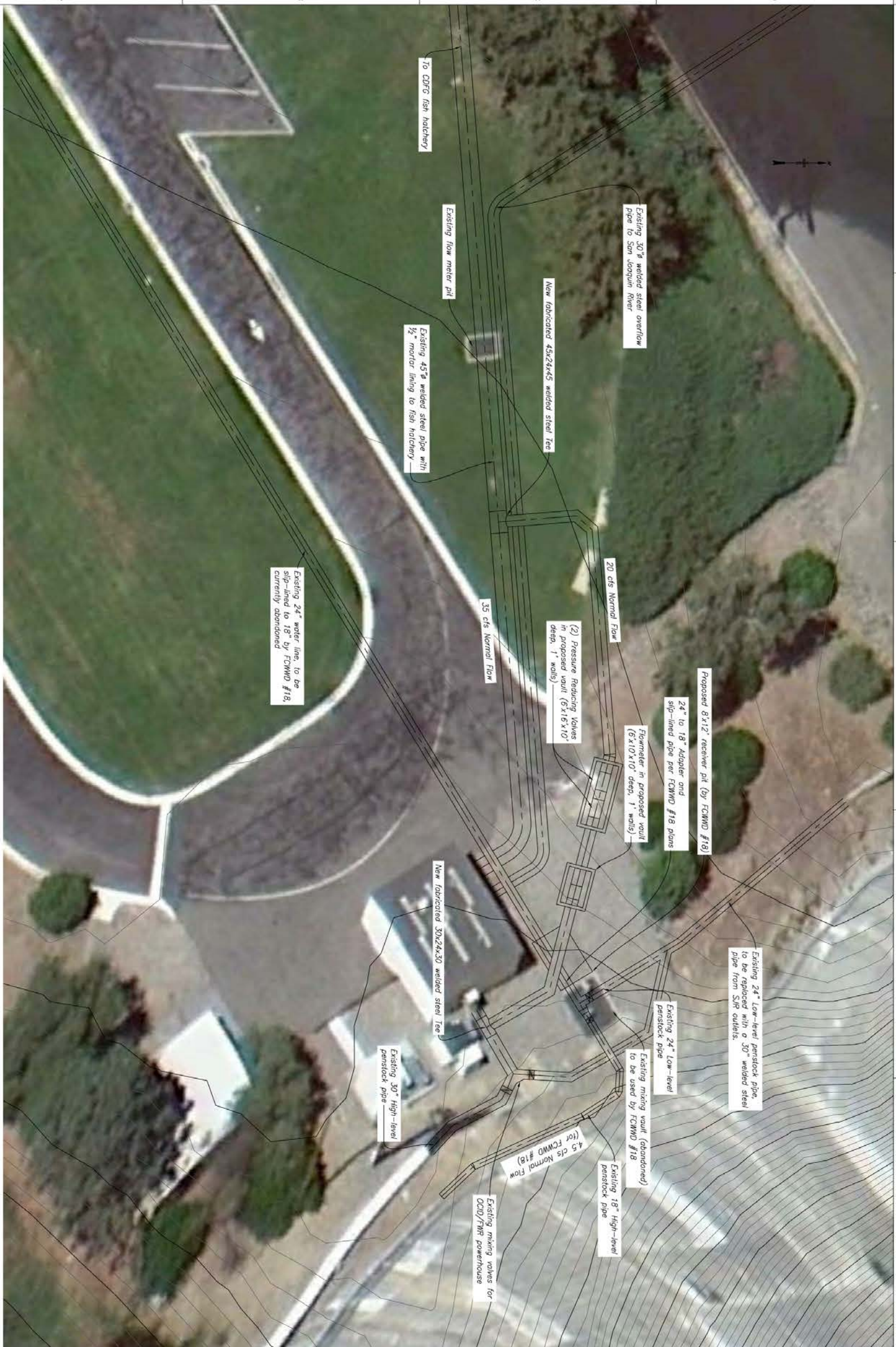

PROPOSED SITE PLAN

DESIGNED BY JERRY LONGSBILL	APPROVED BY JERRY LONGSBILL
DRAWN BY JERRY LONGSBILL	CHECKED BY JERRY LONGSBILL
DATE 11/27/12	SCALE AS SHOWN
PROJECT NO. 02029400	

ALWAYS THINK SAFETY

U.S. DEPARTMENT OF THE INTERIOR
BUREAU OF RECLAMATION
CENTRAL VALLEY PROJECT
FRIANT DIVISION - CALIFORNIA
CONSERVATION AND RESEARCH FACILITY
FRIANT FISH HATCHERY
20 CFS BYPASS PIPELINE ALTERNATIVE
PROPOSED SITE PLAN

Use Only

No Distribution

RECLAMATION
Managing Water in the West



PROPOSED GROUNDWATER WELL SITE PLAN

SCALE OF FEET
0 2000 4000 6000

DESIGNED - JENNIFER L. GIBSON
DRAWN - JESSICA L. GIBSON
CHECKED - JESSICA L. GIBSON
TECH. APPROV. - JWG - JWG
APPROVED - JWG - JWG
DENVER, COLORADO

FIGURE 1
SHEET 1 OF 1

ALWAYS THINK SAFETY
U.S. DEPARTMENT OF THE INTERIOR
BUREAU OF RECLAMATION
CENTRAL VALLEY PROJECT
FRIANT DIVISION - CALIFORNIA
FRIANT FISH HATCHERY
GROUNDWATER WELLS - ALTERNATIVE 2
PROPOSED SITE PLAN

For Internal Use Only
Draft
Not For Distribution

RECLAMATION
Managing Water for the West

C. APPENDIX C – Cost Estimates

FEATURE: San Joaquin River Restoration Program Friant Fish Hatchery Salmonid Conservation & Research Facility Alternative 1 - 20 cfs Bypass Pipeline	PROJECT: Central Valley Project - California
Civil	WOID: A029F ESTIMATE LEVEL: Appraisal
	REGION: MP UNIT PRICE LEVEL: Oct-12
	FILE: H:\D8170\Common\Jatton\San Joaquin River Restoration Program\Friant Fish Hatchery Pipeline or Wells\Estimates\Alternative 1\SJRRP Friant Fish Hatchery Alt 1 02-05-2013.xlsx\Sheet7

PLANT ACCOUNT	PAY ITEM	DESCRIPTION	CODE	QUANTITY	UNIT	UNIT PRICE	AMOUNT
	1	Site & 24" Bypass Pipe Trench Items:					
	1A	Unwatering (5 gpm pump, 4 month duration, 50% run-time for precipitation)	8140	1	ls	\$13,000.00	\$13,000.00
	1B	Stripping (1' deep, lawn & gravel parking lot)	8140	440	cy	\$7.50	\$3,300.00
	1C	Common Pipe Excavation (10' deep, 2:1 in soils)	8140	1,000	cy	\$8.00	\$8,000.00
	1D	Pipe Bedding (4" thick, select fill material)	8140	7.8	cy	\$84.00	\$655.20
	1E	Compacted Backfill to 0.7 OD	8140	44	cy	\$100.00	\$4,400.00
	1F	Compacting backfill (to 90% relative density)	8140	44	cy	\$20.00	\$880.00
	1G	Uncompacted backfill above pipe to O.G.	8140	790	cy	\$8.80	\$6,952.00
	1H	Replacing gravel surfacing (1" thick)	8140	135	cy	\$76.00	\$10,260.00
	1I	Replace lawn & topsoil, 1 foot deep	8140	570	sy	\$4.50	\$2,565.00
	1J	Reinforced concrete thrust block (7' x 7' x 7', 4,000 psi min.)	8140	12	cy	\$700.00	\$8,400.00
	1K	Reinforcement for thrust block (150 lbs/cy)	8140	1,800	lbs	\$2.00	\$3,600.00
	1L	Cementitious material (.282 tons/cy, 6 sack mix)	8140	3.4	tons	\$210.00	\$714.00
	2	Flow-meter and PRV Valve Vault Items:					
		*Note that there is (1) 8' x 10' flow meter vault & (1) 16' x 8' PRV vault. PRV vaults contains (2) PRV's to reduce head to match existing pipe.					
	2A	Structure excavation (2:1 in soils, 10' deep)	8140	225	cy	\$14.00	\$3,150.00
	2B	Reinforced Concrete (4,500 psi min.)	8140	40	cy	\$1,100.00	\$44,000.00
	2C	Reinforcement (150 lbs/cy)	8140	6,000	lbs	\$2.00	\$12,000.00
	2D	Cementitious Materials (6 sack, 0.282 tons/cy)	8140	11.3	tons	\$210.00	\$2,373.00
	2E	Structural Backfill	8140	150	cy	\$15.00	\$2,250.00
	2F	Compacting structural backfill (90% Rel. Dens.)	8140	150	cy	\$15.00	\$2,250.00
	2G	Alum. grating (2" I-bar, 19-2 spacing, 5.1#/sf)	8140	670	lbs	\$12.00	\$8,040.00
	2H	Steel access ladder (10 ft tall, embed into vault wall @ corner, includes a removable "Ladder-Up" safety rail system through grating)	8140	2	ea	\$3,700.00	\$7,400.00
	2I	Steel bollards (8' tall, embed 4', fill with concrete)	8140	8	ea	\$1,500.00	\$12,000.00
SUBTOTAL THIS SHEET							\$156,189.20

QUANTITIES		PRICES	
BY Jeremy Lorberau	CHECKED W. Chris Duke, P.E.	BY <i>[Signature]</i> Jim Jaton, P.E., C.C.E	CHECKED <i>[Signature]</i> 2/5/13
DATE PREPARED 11/29/12	PEER REVIEW / DATE W. Chris Duke, P.E.	DATE PREPARED 02/05/13	PEER REVIEW / DATE Tom Hanke <i>[Signature]</i> 2/5/13

FEATURE: San Joaquin River Restoration Program Friant Fish Hatchery Salmonid Conservation & Research Facility Alternative 1 - 20 cfs Bypass Pipeline		PROJECT: Central Valley Project - California	
WOID: A029F		ESTIMATE LEVEL: Appraisal	
REGION: MP		UNIT PRICE LEVEL: Oct-12	
FILE:		H:\D8170\Comman\Jetton\San Joaquin River Restoration Program\Friant Fish Hatchery Pipeline or Wells\Estimates\Alternative 1\SJRRP Friant Fish Hatchery Alt 1 02-05-2013.xlsx\Sheet7	

Civil

PLANT ACCOUNT	PAY ITEM	DESCRIPTION	CODE	QUANTITY	UNIT	UNIT PRICE	AMOUNT
	3	OCID Powerhouse Bypass Pipe Items:					
	3A	24" mortar lined, epoxy coated welded steel pipe 0.375" thick, 103 lbs/ft, 137 linear ft	8140	14,000	lbs	\$3.80	\$53,200.00
	3B	30x30x24 Steel Tee, Epoxy coated, HC=150 psi	8140	1	ea	\$18,000.00	\$18,000.00
	3C	45x45x24 Steel Tee, Epoxy coated, HC=150 psi	8140	1	ea	\$27,000.00	\$27,000.00
	3D	24" Gate Isolation Valve AWWA C504 Class 150	8140	2	ea	\$23,000.00	\$46,000.00
	3E	24" AWWA Flanges, Class 150	8140	2	ea	\$5,200.00	\$10,400.00
	4	Temporary Pump (for Bypass tie-in) Items:					
		Temporary 35 cfs pump to deliver water to Friant Fish Hatchery during (2) Tee installations. The temporary pump will be trailer mounted, placed along the San Joaquin River on California DFG property, with intakes placed directly in the river. Temporary piping will be run to the aeration towers as the delivery location. Temporary pump will be required for 7 days (allows for 3 days per Tee installation, sequentially placed, and 1 extra day for emergency/schedule slip). Please see quote obtained from 'Rain for Rent' during design period for specific details, and note the new 7-day duration. Include backup generator and standby pump in cost.	8140	1	ls	\$105,000.00	\$105,000.00
	5	SJR Outlet Pipe Demolition Items:					
	5A	Dewater, demo & remove existing 24" welded steel pipeline, 251 linear feet, 0.25" wall	8140	17,000	lbs	\$1.30	\$22,100.00
	5B	Remove existing 24x24x24 off-angle Tee, keep the existing 24" pipe to the abandoned mixing vault intact for connection included in this work	8140	1	ls	\$1,900.00	\$1,900.00
	5C	Remove existing 24x30 reducer at mixing valves	8140	1	ls	\$1,900.00	\$1,900.00
	5D	Demolish & remove existing concrete saddle blocks (5 blocks, 12' tall)	8140	7.8	cy	\$410.00	\$3,198.00
SUBTOTAL THIS SHEET							\$288,698.00

QUANTITIES		PRICES	
BY Jeremy Lorberau	CHECKED W. Chris Duke, P.E.	BY <i>[Signature]</i> Jim Jetton, P.E., C.C.E.	CHECKED <i>[Signature]</i> 2/5/13
DATE PREPARED 11/29/12	PEER REVIEW / DATE W. Chris Duke, P.E.	DATE PREPARED 02/05/13	PEER REVIEW / DATE Tom Hanke <i>[Signature]</i> 2/5/13

FEATURE: San Joaquin River Restoration Program Friant Fish Hatchery Salmonid Conservation & Research Facility Alternative 1 - 20 cfs Bypass Pipeline		PROJECT: Central Valley Project - California	
WOID: A029F		ESTIMATE LEVEL: Appraisal	
REGION: MP		UNIT PRICE LEVEL: Oct-12	
FILE:		H:\D81701\Common\Jetton\San Joaquin River Restoration Program\Friant Fish Hatchery Pipeline or Wells\Estimates\Alternative 1\SJRRP Friant Fish Hatchery Alt 1 02-05-2013.xlsx\Sheet7	

Civil

PLANT ACCOUNT	PAY ITEM	DESCRIPTION	CODE	QUANTITY	UNIT	UNIT PRICE	AMOUNT
	6	SJR Outlet to OCID Powerhouse Pipe Items:					
	6A	30" mortar lined, epoxy coated welded steel pipe 0.375" thick, 127 lbs/ft, 235 linear ft	8140	30,000	lbs	\$3.80	\$114,000.00
	6B	30x30x24 steel fitting, Tee w/ 45 degree angle, Epoxy coated, HC=150 psi	8140	1	ea	\$18,000.00	\$18,000.00
	6C	New concrete saddle blocks to support steel pipe from SJR outlet to daylight into hill slope. Blocks are 12' tall, 1' deep, 3.5' wide, 20' O.C.	8140	11	cy	\$2,300.00	\$25,300.00
	6D	Reinforcement	8140	1,650	lbs	\$2.00	\$3,300.00
	6E	Cementitious Materials (6 sack, 0.282 tons/cy)	8140	3.1	tons	\$210.00	\$651.00
	7	30" Main Pipe Trench Items:					
	7A	Unwatering (5 gpm pump, 4 month duration, 50% run-time for precipitation)	8140	1	ls	\$13,000.00	\$13,000.00
	7B	Stripping (1' deep, native veg. & gravel)	8140	360	cy	\$7.50	\$2,700.00
	7C	Common Pipe Excavation (10' deep, 2:1 in soils)	8140	860	cy	\$8.00	\$6,880.00
	7D	Pipe Bedding (4" thick, select fill material)	8140	8.3	cy	\$84.00	\$697.20
	7E	Compacted Backfill to 0.7 OD	8140	60	cy	\$100.00	\$6,000.00
	7F	Compacting backfill (to 90% relative density)	8140	60	cy	\$20.00	\$1,200.00
	7G	Uncompacted backfill above pipe to O.G.	8140	770	cy	\$8.80	\$6,776.00
	7H	Replacing gravel surfacing (1' thick)	8140	455	sy	\$24.00	\$10,920.00
	7I	Replace native topsoil from stripping, 1 foot deep	8140	660	sy	\$2.00	\$1,320.00
	7J	(2) Reinforced concrete thrust block (7' x 7' x 7', 4,000 psi min.)	8140	24	cy	\$700.00	\$16,800.00
	7K	Reinforcement for thrust block (150 lbs/cy)	8140	3,600	lbs	\$2.00	\$7,200.00
	7L	Cementitious material (.282 tons/cy, 6 sack mix)	8140	3.4	tons	\$210.00	\$714.00
SUBTOTAL THIS SHEET							\$235,458.20

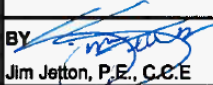
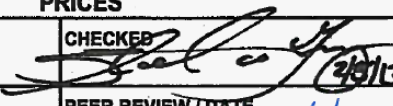
QUANTITIES		PRICES	
BY Jeremy Lorberau	CHECKED W. Chris Duke, P.E.	BY  Jim Jetton, P.E., C.C.E.	CHECKED  Tom Hanke
DATE PREPARED 11/29/12	PEER REVIEW / DATE W. Chris Duke, P.E.	DATE PREPARED 02/05/13	PEER REVIEW / DATE NA 2/5/13



FEATURE: San Joaquin River Restoration Program Friant Fish Hatchery Salmonid Conservation & Research Facility Alternative 1 - 20 cfs Bypass Pipeline		PROJECT: Central Valley Project - California	
WOID: A029F	ESTIMATE LEVEL: Appraisal	REGION: MP	UNIT PRICE LEVEL: Oct-12
FILE: H:\D8170\Common\Jetton\San Joaquin River Restoration Program\Friant Fish Hatchery Pipeline or Wells\Estimates\Alternative 1\SJRRP Friant Fish Hatchery Alt 1 02-05-2013.xlsx\Sheet7			

PLANT ACCOUNT	PAY ITEM	DESCRIPTION	CODE	QUANTITY	UNIT	UNIT PRICE	AMOUNT
	8	Removing Outlet Pipes	8420				
	8A	Remove the two 110" X 96" Flanged reducers Length of each reducer = 5'-5" Estimated Weight per Reducer = 8633 lbs. (cast iron) Weight for 2 Reducer = 17300 lbs.		17,300	lbs.	\$1.30	\$22,490.00
		Procedure (for each reducer, there are 2 reducers): For each location, unbolt existing 110" x 96" flanged reducer. Move the existing 96" Hollow-Jet Valve (86,000 lbs) with existing gantry crane. Lift up the reducer and remove. Total number of fasteners removed = 120 - 2" Dia. Bolts and nuts.					
	8B	Remove 18" diameter steel pipe: Length = 25 ft. Wt. = 25 * 48 lbs./ft. = 1200 Lbs.		1,200	Lbs.	\$2.10	\$2,520.00
SUBTOTAL THIS SHEET							\$25,010.00

QUANTITIES		PRICES	
BY Rick Frisz	CHECKED Nathan Nakamoto	BY Jim Jetton, P.E., C.C.E.	CHECKED <i>[Signature]</i>
DATE PREPARED 12/11/12	PEER REVIEW / DATE Rick Frisz	DATE PREPARED 02/05/13	PEER REVIEW / DATE Tom Hanke <i>[Signature]</i> 2/5/13

FEATURE: San Joaquin River Restoration Program Friant Fish Hatchery Salmonid Conservation & Research Facility Alternative 1 - 20 cfs Bypass Pipeline	PROJECT: Central Valley Project - California
WOID: A029F	ESTIMATE LEVEL: Appraisal
REGION: MP	UNIT PRICE LEVEL: Oct-12
FILE: H:\D8170\Common\JJetton\San Joaquin River Restoration Program\Friant Fish Hatchery Pipeline or Wells\Estimates\Alternative 1\SJRFRP Friant Fish Hatchery Alt 1 02-05-2013.xlsx\Sheet7	

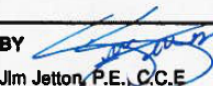
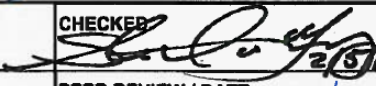
PLANT ACCOUNT	PAY ITEM	DESCRIPTION	CODE	QUANTITY	UNIT	UNIT PRICE	AMOUNT
	9	Installing Outlet Pipes	8420				
	9A	Install the two reducers: Each reducer section: 110" ID X 96" ID					
		Estimated wt. per reducer section = 8600 lbs.					
		Total wt. for 2 reducer sections = 17200 lbs.		17,200	lbs.	\$12.50	\$215,000.00
		Procedure (for each reducer, there are 2 reducers):					
		For each location, install new 110" X 96" flanged reducer. Reinstall the existing 96" Hollow-Jet Valve (86,000 lbs.) with existing gantry crane.					
		Total number of fasteners installed = 120 - 2" Dia. Bolts and nuts.					
	10	Install straight steel pipe:					
	10A	18" Sch. 10, 15 ft. @ 48 lbs/ft.		720	lbs.	\$6.00	\$4,320.00
	10B	24" ID X 1/4" wall, 8 ft. @ 64 lbs/ft		512	lbs	\$6.00	\$3,072.00
	10C	30" ID X 1/4" wall, 40 ft. @ 80 lbs/ft		3200	lbs	\$5.00	\$16,000.00
SUBTOTAL THIS SHEET							\$238,392.00

QUANTITIES		PRICES	
BY Rick Frisz	CHECKED Nathan Nakamoto	BY  Jim Jetton, P.E., C.C.E.	CHECKER  Tom Hanke
DATE PREPARED 12/11/12	PEER REVIEW / DATE Rick Frisz	DATE PREPARED 02/05/13	PEER REVIEW / DATE  Tom Hanke

FEATURE: San Joaquin River Restoration Program Friant Fish Hatchery Salmonid Conservation & Research Facility Alternative 1 - 20 cfs Bypass Pipeline	PROJECT: Central Valley Project - California
Hydraulic Equipment Group	
WOID: A029F	ESTIMATE LEVEL: Appraisal
REGION: MP	UNIT PRICE LEVEL: Oct-12
FILE: H:\D8170\Common\Jetton\San Joaquin River Restoration Program\Friant Fish Hatchery Pipeline or Wells\Estimates\Alternative 1\SJRRP Friant Fish Hatchery Alt 1 02-05-2013.xlsx\Sheet7	

PLANT ACCOUNT	PAY ITEM	DESCRIPTION	CODE	QUANTITY	UNIT	UNIT PRICE	AMOUNT
	11	Valves	8420				
	11A	2 - 24" Dia. Class 150 AWWA butterfly valves manually operated, 1085 lbs. ea.		2,170	lbs.	\$10.50	\$22,785.00
	11B	2 - 24" Dia. Class 150 Pressure reducing valves Flanged ends: 2900 Lbs. ea.		5,800	lbs.	\$6.90	\$40,020.00
SUBTOTAL THIS SHEET							\$62,805.00

QUANTITIES		PRICES	
BY Rick Frisz	CHECKED Nathan Nakamoto	BY Jim Jetton, P.E., C.C.E.	CHECKED Tom Hanke
DATE PREPARED 12/11/12	PEER REVIEW / DATE Rick Frisz	DATE PREPARED 02/05/13	PEER REVIEW / DATE Tom Hanke 2/5/13

FEATURE: San Joaquin River Restoration Program Friant Fish Hatchery Salmonid Conservation & Research Facility Alternative 1 - Flowmeter	PROJECT: Central Valley Project - California
WOID: A029F	ESTIMATE LEVEL: Appraisal
REGION: MP	UNIT PRICE LEVEL: Oct-12
FILE: H:\D8170\Common\JJetton\San Joaquin River Restoration Program\Friant Fish Hatchery Pipeline or Wells\Estimates\Alternative 1\SJRRP Friant Fish Hatchery Alt 1 02-05-2013.xlsx\Sheet7	

Civil

PLANT ACCOUNT	PAY ITEM	DESCRIPTION	CODE	QUANTITY	UNIT	UNIT PRICE	AMOUNT
	12	F&I Magnetic flowmeter system in the 20 cfs, 24" dia. pipelines, electromagnetic flowmeters with flanged, cylindrical flow-tube, Tefzel liner, grounding rings, and remote transmitter (flowrate & totalizer) (equal to Model FM656 TigermagEP as manufactured by Sparing Instruments)	86-68410	1	L.S.	\$29,000.00	\$29,000.00
		- 24" Dia. flowmeter, approx. 860 lbs.					
SUBTOTAL THIS SHEET							\$29,000.00

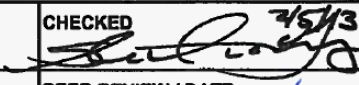
QUANTITIES		PRICES	
BY R. Stephen	CHECKED S. Reed	BY  Jim Jetton, P.E., C.C.E.	CHECKED  2/5/13
DATE PREPARED 12/07/12	PEER REVIEW / DATE Daivd Hulse	DATE PREPARED 02/05/13	PEER REVIEW / DATE Tom Hanke 2/5/13

FEATURE: San Joaquin River Restoration Program Friant Fish Hatchery Salmonid Conservation & Research Facility Alternative 1 - 20 cfs Bypass Pipeline <p style="text-align: center;">Summary Sheet</p>	PROJECT: Central Valley Project - California <table border="1" style="width:100%; border-collapse: collapse;"> <tr> <td style="width:50%;">WOID: A029F</td> <td style="width:50%;">ESTIMATE LEVEL: Appraisal</td> </tr> <tr> <td>REGION: MP</td> <td>UNIT PRICE LEVEL: Oct-12</td> </tr> <tr> <td colspan="2">FILE: H:\D81701\Common\Jetton\San Joaquin River Restoration Program\Friant Fish Hatchery Pipeline or Wells\Estimates\Alternative 1\SJRRP Friant Fish Hatchery Alt 1 02-05-2013.xlsx\Sheet7</td> </tr> </table>	WOID: A029F	ESTIMATE LEVEL: Appraisal	REGION: MP	UNIT PRICE LEVEL: Oct-12	FILE: H:\D81701\Common\Jetton\San Joaquin River Restoration Program\Friant Fish Hatchery Pipeline or Wells\Estimates\Alternative 1\SJRRP Friant Fish Hatchery Alt 1 02-05-2013.xlsx\Sheet7	
WOID: A029F	ESTIMATE LEVEL: Appraisal						
REGION: MP	UNIT PRICE LEVEL: Oct-12						
FILE: H:\D81701\Common\Jetton\San Joaquin River Restoration Program\Friant Fish Hatchery Pipeline or Wells\Estimates\Alternative 1\SJRRP Friant Fish Hatchery Alt 1 02-05-2013.xlsx\Sheet7							

PLANT ACCOUNT	PAY ITEM	DESCRIPTION	CODE	QUANTITY	UNIT	UNIT PRICE	AMOUNT
		Subtotal					
		Sheet 1		8140			\$156,189.20
		Sheet 2		8140			\$288,698.00
		Sheet 3		8140			\$235,458.20
		Sheet 4		8420			\$25,010.00
		Sheet 5		8420			\$238,392.00
		Sheet 6		8420			\$62,805.00
		Sheet 7		8140			\$29,000.00
		Subtotal for 72 Wells					\$1,035,552.40
		Mobilization	5%	+/-			\$52,000.00
		Subtotal with Mobilization					\$1,087,552.40
		Contract Cost Allowances (Sum of):	20%	+/-			\$212,447.60
		Design Contingencies, 15 % (+/-)					
		APS, 5 % (+/-). Type of procurement: Request for Proposal (Assumed)					
		CONTRACT COST					\$1,300,000.00
		Construction Contingencies	25%	+/-			\$350,000.00
		FIELD COST (Unit Price Level Oct 2012)					\$1,650,000.00
		Escalation to Notice to Proceed (NTP), from Unit Price Level (Oct 2012) to NTP (Oct 2015)					\$150,000.00
		at 3.0% per year for 3.00 years					
		FIELD COST (with Escalation to NTP, Price Level Oct 2015)					\$1,800,000.00
		Non-Contract Costs				To be determined by the appropriate responsible office	
		CONSTRUCTION COST				To be determined by the appropriate responsible office	

Ref.: For appropriate use and terminology, see Reclamation Manual, Directives and Standards FAC; 09-01, 09-02 and 09-03.

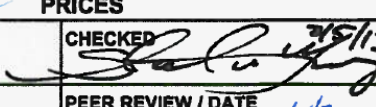
QUANTITIES		PRICES	
BY 8140 & 8420	CHECKED See Previous	BY  Jim Jetton, P.E., C.C.E	CHECKED  2/5/13
DATE PREPARED See Previous	PEER REVIEW / DATE See Previous	DATE PREPARED 02/05/13	PEER REVIEW / DATE Tom Hanke 2/5/13

FEATURE: San Joaquin River Restoration Program Friant Fish Hatchery Salmonid Conservation & Research Facility Alternative 2 - 20 cfs Groundwater Wells	PROJECT: Central Valley Project - California
WOID: A029F	ESTIMATE LEVEL: Appraisal
REGION: MP	UNIT PRICE LEVEL: Oct-12
FILE: H:\D8170\Common\Jetton\San Joaquin River Restoration Program\Friant Fish Hatchery Pipeline or Wells\Estimates\Alternative 2\SJRRP Friant Fish Hatchery Alt 2 02-05-2013.xlsx\Field Cost Summary Sht Template	

Civil

PLANT ACCOUNT	PAY ITEM	DESCRIPTION	CODE	QUANTITY	UNIT	UNIT PRICE	AMOUNT
	1	Site Items:					
	1A	Pipe Trench Unwatering (4-50 gpm pumps, 6 month duration, as-needed (20% run-time)	8140	1	ls	\$15,000.00	\$15,000.00
	1B	Storage Tank Exc. Unwatering (2-50 gpm pumps, 6 month duration, as-needed (20% run-time)	8140	1	is	\$10,000.00	\$10,000.00
	1C	Stripping (6" deep, open field soils)	8140	500,000	cy	\$1.50	\$750,000.00
	1D	Dust abatement (1/8" spray, 3x/day, road work per day = 1162', 261 days duration)	8140	850	Mgal	\$90.00	\$76,500.00
		Dewatering not anticipated due to height of the groundwater table determined using well logs in the area.					
	2	Access Roadway Items:					
		Roads consist of (72) well access gravel roads; consisting of 3" gravel over 6" aggregate base course. Roads for initial well drilling/setup and permanent O&M needs.					
		Total length of roadway (12' wide) = 151,400 ft					
	2A	3" Gravel roadway surfacing	8140	17,000	cy	\$56.00	\$952,000.00
	2B	6" Aggregate Base course	8140	34,000	cy	\$51.00	\$1,734,000.00
	3	Temporary Drill Pads:					
	3A	Provide temporary staging area for well drilling, testing, and setup. Each site is 50' x 75', with (72) total well sites to be installed.	8140	30,000	sy	\$1.85	\$55,500.00
	4	Permanent Well Sites:					
		Permanent well sites are 20' x 20' with security fencing (std. 8' chain-link w/ 2' barbed-wire)	8140	3,200	sy	No Costs. See 4A.	
	4A	Fencing	8140	5,800	lin ft	\$52.00	\$301,600.00
		SUBTOTAL THIS SHEET					\$3,894,600.00

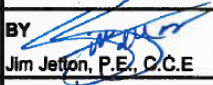
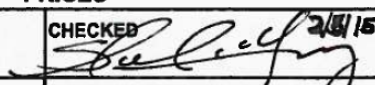
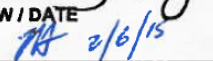
QUANTITIES		PRICES	
BY Jeremy Lorberau	CHECKED W. Chris Duke, P.E.	BY  Jim Jetton, P.E., D.C.E.	CHECKED  Tom Hanke
DATE PREPARED 12/07/12	PEER REVIEW / DATE W. Chris Duke, P.E.	DATE PREPARED 02/05/13	PEER REVIEW / DATE Tom Hanke  2/6/13

FEATURE: San Joaquin River Restoration Program Friant Fish Hatchery Salmonid Conservation & Research Facility Alternative 2 - 20 cfs Groundwater Wells		PROJECT: Central Valley Project - California	
WOID: A029F		ESTIMATE LEVEL: Appraisal	
REGION: MP		UNIT PRICE LEVEL: Oct-12	
FILE:		H:\D8170\Common\Jjetton\San Joaquin River Restoration Program\Friant Fish Hatchery Pipeline or Wells\Estimates\Alternative 2\JRPP Friant Fish Hatchery Alt 2 02-05-2013.xlsx\Sheet 2	

PLANT ACCOUNT	PAY ITEM	DESCRIPTION	CODE	QUANTITY	UNIT	UNIT PRICE	AMOUNT
	5	Well Drilling Items:					
	5A	Major work for well drilling is shown on separate cost estimate worksheet. Line item shown is to cost out haul-off of drill cuttings. Assume a 15 mile one-way haul distance to disposal site.	8140	670	cy	\$23.00	\$15,410.00
	6	Pipe Earthwork Items:					
	6A	Common Pipe Excavation (Varies 6' to 8' deep, 2:1 slope in soils)	8140	1,550,000	cy	\$4.70	\$7,285,000.00
	6B	Pipe Bedding (4" thick, select fill material)	8140	21,000	cy	\$70.00	\$1,470,000.00
	6C	Compacted Embedment (6" over crown for pipe dia. ≤ 12"; 0.7 OD for > 12" diameters) Reuse Excavated Material	8140	160,000	cy	\$9.40	\$1,504,000.00
	6D	Compacting Embedment (to 90% relative density)	8140	160,000	cy	\$6.90	\$1,104,000.00
	6E	Uncompacted Backfill (includes volume of stripped fill, replace in top 6")	8140	1,600,000	cy	\$4.50	\$7,200,000.00
	7	Pipe Items:					
		All well pipes and manifold are HDPE PE 3408, DR 17.0 IPS rated for 100 psi (AWWA M55). Pipes run from wells to well-strings to manifold to booster pumping plant. Delivery pipe runs from booster pumping plant to delivery located at CDFG hatchery (1.25 miles).					
SUBTOTAL THIS SHEET							\$18,578,410.00

QUANTITIES		PRICES	
BY Jeremy Lorberau	CHECKED W. Chris Duke, P.E.	BY <i>[Signature]</i> Jim Jetton, P.E., C.C.E.	CHECKED <i>[Signature]</i> 2/6/13
DATE PREPARED 12/07/12	PEER REVIEW / DATE W. Chris Duke, P.E.	DATE PREPARED 02/05/13	PEER REVIEW / DATE Tom Hanke <i>[Signature]</i> 2/6/13

FEATURE: San Joaquin River Restoration Program Friant Fish Hatchery Salmonid Conservation & Research Facility Alternative 2 - 20 cfs Groundwater Wells		PROJECT: Central Valley Project - California	
WOID: A029F		ESTIMATE LEVEL: Appraisal	
REGION: MP		UNIT PRICE LEVEL: Oct-12	
Civil		FILE: H:\D8170(Common\Jetton\San Joaquin River Restoration Program\Friant Fish Hatchery Pipeline or Wells\Estimates\Alternative 2\SJRRP Friant Fish Hatchery Alt 2 02-05-2013.xlsx)Field Cost Summary Sht Template	

PLANT ACCOUNT	PAY ITEM	DESCRIPTION	CODE	QUANTITY	UNIT	UNIT PRICE	AMOUNT
		Pipe Items (continued):					
	7A	(72) 25' long well to well-string pipes, 6" dia., DR 17, 3.34 lbs/ft, 1875 ft total	8140	6,300	lbs	\$3.60	\$22,680.00
	7B	Telescoping well-string pipes, 6" dia., DR 17 3.34 lbs/ft, 10,000 ft total	8140	33,000	lbs	\$3.60	\$118,800.00
	7C	Telescoping well-string pipes, 8" dia., DR 17 5.65 lbs/ft, 40,000 ft total	8140	230,000	lbs	\$3.00	\$690,000.00
	7D	Telescoping well-string pipes, 10" dia., DR 17 8.78 lbs/ft, 250,000 ft total	8140	2,200,000	lbs	\$2.50	\$5,500,000.00
	7E	Telescoping well-string pipes, 12" dia., DR 17 12.36 lbs/ft, 90,000 ft total	8140	1,100,000	lbs	\$2.40	\$2,640,000.00
	7F	Telescoping well-string pipes, 14" dia., DR 17 14.91 lbs/ft, 40,000 ft total	8140	600,000	lbs	\$2.30	\$1,380,000.00
	7G	Telescoping well-string pipes, 16" dia., DR 17 19.46 lbs/ft, 40,000 ft total	8140	780,000	lbs	\$2.25	\$1,755,000.00
		Manifold pipes connect from end of well-string to adjacent well string and to the booster pumping plant at end of last well-string.					
	7H	Manifold pipe, 16" dia., DR 17, 19.46 lbs/ft, length is 2,000 ft total	8140	39,000	lbs	\$2.20	\$85,800.00
	7I	Manifold pipe, 24" dia., DR 17, 43.81 lbs/ft, length is 2,000 ft total	8140	88,000	lbs	\$2.15	\$189,200.00
	7J	Manifold pipe, 30" dia., DR 17, 68.45 lbs/ft, length is 2,000 ft total	8140	140,000	lbs	\$2.00	\$280,000.00
	7K	Manifold pipe, 30" dia., DR 17, 68.45 lbs/ft, length is 2,000 ft total	8140	140,000	lbs	\$2.00	\$280,000.00
		Delivery pipe is 30" diameter HDPE PE 3408, DR 26 (64 psi) that runs from the booster pumping plant to the CDFG Hatchery delivery point. The length of the delivery pipe is 1.25 miles.					
	7L	Delivery pipe, 30" dia., DR 26, 45.78 lbs/ft, length is 6,600 ft total	8140	305,000	lbs	\$2.10	\$640,500.00
		SUBTOTAL THIS SHEET					\$13,581,980.00

QUANTITIES		PRICES	
BY Jeremy Lorberau	CHECKED W. Chris Duke, P.E.	BY Jim Jetton, P.E., C.C.E.	CHECKED 2/5/13 Tom Hanke
DATE PREPARED 12/07/12	PEER REVIEW / DATE W. Chris Duke, P.E.	DATE PREPARED 02/05/13	PEER REVIEW / DATE 2/6/13

FEATURE: San Joaquin River Restoration Program Friant Fish Hatchery Salmonid Conservation & Research Facility Alternative 2 - 20 cfs Groundwater Wells		PROJECT: Central Valley Project - California	
WOID: A029F		ESTIMATE LEVEL: Appraisal	
REGION: MP		UNIT PRICE LEVEL: Oct-12	
FILE:		H:\D8170\Common\J\Jetton\San Joaquin River Restoration Program\Friant Fish Hatchery Pipeline or Wells\Estimates\Alternative 2\JRPP Friant Fish Hatchery Alt 2 02-05-2013.xlsx\Sheet 4	

PLANT ACCOUNT	PAY ITEM	DESCRIPTION	CODE	QUANTITY	UNIT	UNIT PRICE	AMOUNT
	8	Underground concrete storage tank: Underground concrete storage tank is located at booster pumping plant to provide storage and provide suction head for the pumps. Tank is reinforced concrete, depth = 24', length/width = 154'. Roof, slab, and walls are 2' thick. Tank has 2' x 2' columns @ 15' O.C. Inside. Tank stores about 6 hours of water @ 20 cfs flow, and has a 3.23 Million gallon capacity.					
	8A	Reinforced concrete (4,500 psi)	8140	4,800	cy	\$800.00	\$3,840,000.00
	8B	Reinforcement (150 lbs/cy)	8140	720,000	lbs	\$1.50	\$1,080,000.00
	8C	Cementitious Materials (0.282 tons/cy)	8140	1,350	tons	\$200.00	\$270,000.00
	8D	9" Waterstop (in slab and walls)	8140	3,850	lin ft	\$32.00	\$123,200.00
	9	Underground Tank Earthwork:					
	9A	Structural excavation (25' deep, 2:1 slopes in soil, allows for 5' horizontal over-excavation for forming and working area)	8140	43,000	cy	\$10.00	\$430,000.00
	9B	Structural backfill (25' deep about tank) Reuse Excavated Material	8140	21,000	cy	\$10.00	\$210,000.00
	9C	Compacting structural backfill (to 90% rel. dens.)	8140	21,000	cy	\$10.00	\$210,000.00
	9D	Access hatches (3' x 3' Aluminum, Bilco-style, locking, mounted to top of tank)	8140	2	ea	\$2,500.00	\$5,000.00
	9E	Access ladder (24' tall steel ladder with cage for fall protection, mounted into concrete walls)	8140	2	ea	\$5,900.00	\$11,800.00
	9F	Security fencing (8' chain link w/ 2' barbed wire, extends 20' outside top of tank perimeter)	8140	780	lin ft	\$52.00	\$40,560.00
	9G	Access gate (double-swing gate, each gate = 12' wide, chain link & barbed wire w/ wheel at base of gate and locking hasp)	8140	1	ea	\$4,500.00	\$4,500.00
	9H	Bollards (10' O.C. around top of tank to prevent vehicle loading on roof of tank, 8' tall, 4' buried)	8140	62	ea	\$1,350.00	\$83,700.00
SUBTOTAL THIS SHEET							\$6,308,760.00

QUANTITIES		PRICES	
BY Jeremy Lorberau	CHECKED W. Chris Duke, P.E.	BY <i>[Signature]</i> Jim Jetton, P.E., C.C.E	CHECKED <i>[Signature]</i> 2/6/13
DATE PREPARED 12/07/12	PEER REVIEW / DATE W. Chris Duke, P.E.	DATE PREPARED 02/05/13	PEER REVIEW / DATE <i>[Signature]</i> 2/6/13 Tom Hanke

FEATURE: San Joaquin River Restoration Program Friant Fish Hatchery Salmonid Conservation & Research Facility Alternative 2 - 20 cfs Groundwater Wells	PROJECT: Central Valley Project - California
Electrical - SCADA	
WOID: A029F	ESTIMATE LEVEL: Appraisal
REGION: MP	UNIT PRICE LEVEL: Oct-12
FILE: H:\D8170\Common\Jetton\San Joaquin River Restoration Program\Friant Fish Hatchery Pipeline or Wells\Estimates\Alternative 2\SJRRP Friant Fish Hatchery Alt 2 02-05-2013.xlsx\Field Cost Summary Sht Template	

PLANT ACCOUNT	PAY ITEM	DESCRIPTION	CODE	QUANTITY	UNIT	UNIT PRICE	AMOUNT
		Site Items:	86-68450				
	10	Furnish and Install:					
	10A	CPU (Desktop computer, monitor, keyboard, mouse)		1	ea	\$6,000.00	\$6,000.00
	10B	Radio Tower ~20-30 feet		1	ea	\$14,500.00	\$14,500.00
	10C	Application Software Programming (Assume ~20 days)		1	ea	\$41,000.00	\$41,000.00
	10D	Radio - Access Point & Antenna (Unlicensed 900 MHz)		1	ea	\$5,500.00	\$5,500.00
	11	3" Diameter Pipe Items (well to manifold):	86-68450				
		Furnish and Install:					
	11A	Radio - Remote I/O & Antenna		75	ea	\$3,100.00	\$232,500.00
	11B	Antenna Pole (Assume 10-20 ft wooden pole)		75	ea	\$1,300.00	\$97,500.00
		Misc. Items		20	%	Included in Items Above	
SUBTOTAL THIS SHEET							\$397,000.00

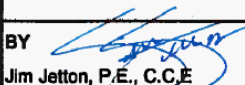
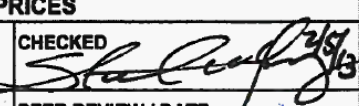
QUANTITIES		PRICES	
BY Jason Schmidt	CHECKED Paul Tinetti	BY  Jim Jetton, P.E., C.C.E	CHECKED  Tom Hanke
DATE PREPARED 12/14/12	PEER REVIEW / DATE V. Hoan 12/14/12	DATE PREPARED 02/05/13	PEER REVIEW / DATE Tom Hanke 2/6/13

FEATURE: San Joaquin River Restoration Program Friant Fish Hatchery Salmonid Conservation & Research Facility Alternative 2 - 20 cfs GW Booster Pumping Units		PROJECT: Central Valley Project - California	
WOID: A029F		ESTIMATE LEVEL: Appraisal	
REGION: MP		UNIT PRICE LEVEL: Oct-12	
FILE: H:\DB170\Common\Jetton\San Joaquin River Restoration Program\Friant Fish Hatchery Pipeline or Wells\Estimates\Alternative 2\SJRRP Friant Fish Hatchery Alt 2 02-06-2013.xlsx\Field Cost Summary Sht Template			

PLANT ACCOUNT	PAY ITEM	DESCRIPTION	CODE	QUANTITY	UNIT	UNIT PRICE	AMOUNT
		FURNISH AND INSTALL:					
	12	2 - Sulzer Pump model SJM-20MS, 1-stage, 880 rpm, vertical mixed-flow pump, Rated 20.6 cfs (9,246 gpm) @ 35 feet TDH, oil-lube line shaft, 19' long - 20" diam. column pipe assembly & 20" diam. above-deck discharge head (6,000 lbs each , 12,000 lbs total) - cast-iron bowls w/ stainless steel impellers and bowl liners - stainless steel shafts (bottom, line, top) - fabricated steel above-deck discharge head - pump vibration limits at Hydraulic Institute Standards - non-witnessed certified pump shop test - pump shop testing with job motor	86-68420	2	ea	\$195,000.00	\$390,000.00
	13	2 - 125 hp, 900 rpm, TEFC, 50-deg. C, vertical induction motor, normal thrust, solid-shaft, L447VP frame, "Premium Efficiency", 3 ph/60 hz/460 volt (2,300 lbs each, 4,600 lbs total)	86-68430	2	ea	\$23,000.00	\$46,000.00
SUBTOTAL THIS SHEET							\$436,000.00

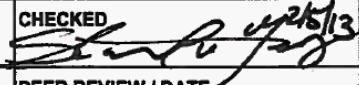
QUANTITIES		PRICES	
BY R. Zelenka	CHECKED Toby Turnage 1/8/13	BY  Jim Jetton, P.E., C.C.E.	CHECKED  2/6/13
DATE PREPARED 1/3/13	PEER REVIEW / DATE Toby Turnage	DATE PREPARED 02/05/13	PEER REVIEW / DATE Tom Hanke 2/6/13

FEATURE: San Joaquin River Restoration Program Friant Fish Hatchery Salmonid Conservation & Research Facility Alternative 2 - Pumping Plant		PROJECT: Central Valley Project - California	
WOID: A029F		ESTIMATE LEVEL: Appraisal	
REGION: MP		UNIT PRICE LEVEL: Oct-12	
FILE: H:\D8170\Common\Jetton\San Joaquin River Restoration Program\Friant Fish Hatchery Pipeline or Wells\Estimates\Alternative 2\SJRRP Friant Fish Hatchery Alt 2 02-05-2013.xlsx\Field Cost Summary Sht Template			

PLANT ACCOUNT	PAY ITEM	DESCRIPTION	CODE	QUANTITY	UNIT	UNIT PRICE	AMOUNT
		<u>Steel Manifold</u>	8420				
		FURNISH-AND-INSTALL THE FOLLOWING:					
	14	Steel Pipe					
	14A	2" Standard (=Sch. 40), L = 8 ft, Wt. = 5.5 lbs/ft		44	lbs.	\$16.50	\$726.00
	14B	20" O.D., Sch. 10, L = 45 ft, Wt. = 53 lbs/ft		2,385	lbs.	\$5.00	\$11,925.00
	14C	24" O.D. Sch. 10, L = 20 ft, Wt. = 64 lbs/ft		1,280	lbs.	\$5.00	\$6,400.00
	15	AWWA Class 150, Motor-Operated Butterfly Valves					
	15A	2 - 20" Dia. Valve, 1085 lbs with motor		2,170	lbs.	\$15.00	\$32,550.00
	16	ANSI Class 150, Tilting Disc Check Valves					
	16A	2 - 20" Dia. Valve, 1685 lbs		3,370	lbs.	\$14.00	\$47,180.00
	17	300 psi, Combination air valves (APCO bulletin 623 model 145C)					
	17A	2 - 2" Dia. Valve, 75 lbs		150	lbs.	\$16.00	\$2,400.00
	18	300 psi, Throttling air valves (APCO bulletin 586 model 144DAT)					
	18A	2 - 2" Dia. Valve, 50 lbs		100	lbs.	\$32.00	\$3,200.00
	19	Ball valves, threaded, full port, bronze, 600 psi cold-water					
	19A	4 - 2" Dia. Valves, 6.7 lbs		27	lbs.	\$200.00	\$5,400.00
		SUBTOTAL THIS SHEET					\$108,781.00



QUANTITIES		PRICES	
BY Ken Smith	CHECKED Lucas Adams	BY Jim Jetton, P.E., C.C.E.	CHECKED Steve [Signature] 4/25/13
DATE PREPARED 01/08/13	PEER REVIEW / DATE Lucas Adams 1/8/13	DATE PREPARED 02/05/13	PEER REVIEW / DATE Tom Hanke 2/6/13

FEATURE: FRIANT FISH HATCHERY WATER SUPPLY ALTERNATIVE 2: DEEP WELLS IN GRANITE Appraisal Estimate Assumed top of Aquifer Unit 500 feet bgs 1 Well	PROJECT: Central Valley Project - California <hr/> WOID: A029F ESTIMATE LEVEL: Appraisal REGION: MP UNIT PRICE LEVEL: Oct-12 FILE: H:\D8170\Commo\JJetton\San Joaquin River Restoration Program\Friant Fish Hatchery Pipeline or Wells\Estimates\Alternative 2\SJRRP Friant Fish Hatchery Alt 2 02-05-2013.xlsx\Field Cost Summary Sht Template
--	---

PLANT ACCOUNT	PAY ITEM	DESCRIPTION	CODE	QUANTITY	UNIT	UNIT PRICE	AMOUNT
---------------	----------	-------------	------	----------	------	------------	--------

The following quantities are for 1 well. There are 72 wells in the well field. See Summary Sheet for cost of 72 wells.

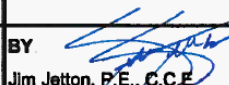
	20	SITE PREPARATION	8320				
	20A	Site Preparation: Mobilization of Equipment		1	LS	Included in Summary	
	20B	Site Preparation: access improvements, leveling drill pad, constructing mud pit, constructing or improving discharge facilities, stockpiling excavate materials		1	LS	\$8,500.00	\$8,500.00
	20C	Site Preparation: Demobilization of Equipment		1	LS	Included in Summary	
	21	PUMPING WELL INSTALLATION	8320				
	21A	Mobilization of Drilling Equipment: drill rig, support equipment and vehicles, materials, ancillary materials and facilities		1	LS	Included in Summary	
	21B	Drilling surface casing borehole, 14" diameter		3.00	LF	\$310.00	\$930.00
	21C	Set Surface Casing; Mild Steel, Schd 10, 14" diameter 0.250 wall thickness; Includes cost of labor, etc.		6.00	LF	\$360.00	\$2,160.00
	21D	Surface Casing cement (Includes 3' stickup)		2.16	FT ³	\$250.00	\$540.00
	21E	Drilling well borehole, 8" diameter ; includes cost of sampling, temporary conductor casing, labor, sample storage, sample handling, etc.		715.00	LF	\$75.00	\$53,625.00
	21F	Install wells, 8" diameter; - includes cost of labor, drill rig, centering guides, etc.		1	LS	\$12,000.00	\$12,000.00
	21G	Blank Casing, 8" Diameter: Galvanized Steel, (includes 3' stickup)		300.00	LF	\$47.00	\$14,100.00
	21H	Locking Mild Steel Surface Cap, 14" diameter		1	EA	\$260.00	\$260.00
	21I	Well development (air lift or pumping) 4 mins min development per foot of open hole		1	LS	\$19,500.00	\$19,500.00
	21J	6" diameter submersible pump or equivalent Grundfos 150S300-15, 30 HP, Nominal		1.00	EA	\$15,000.00	\$15,000.00
	21K	Riser Pipe/Conductor, Sch 40 SS or equivalent		680.00	LF	\$77.00	\$52,360.00
		SUBTOTAL THIS SHEET					\$178,975.00

QUANTITIES		PRICES	
BY W. Robert Talbot, 86-68320	CHECKED John Earle 11/30/2012	BY  Jim Jetton, P.E., C.C.E	CHECKED  Tom Hanke
DATE PREPARED 11/29/12	PEER REVIEW / DATE Leslie Stone 12/04/2012	DATE PREPARED 02/05/13	PEER REVIEW / DATE # 2/6/13

FEATURE: FRIANT FISH HATCHERY WATER SUPPLY ALTERNATIVE 2: DEEP WELLS IN GRANITE Appraisal Estimate Assumed top of Aquifer Unit 500 feet bgs 1 Well		PROJECT: Central Valley Project - California	
WOID: A029F		ESTIMATE LEVEL: Appraisal	
REGION: MP		UNIT PRICE LEVEL: Oct-12	
FILE: H:\D8170\Common\Jettor\San Joaquin River Restoration Program\Friant Fish Hatchery Pipeline or Wells\Estimates\Alternative 2\JRRP Friant Fish Hatchery Alt 2 02-05-2013.xlsx\Field Cost Summary Sht Template			

PLANT ACCOUNT	PAY ITEM	DESCRIPTION	CODE	QUANTITY	UNIT	UNIT PRICE	AMOUNT
The following quantities are for 1 well. There are 72 wells in the well field. See Summary Sheet for cost of 72 wells.							
	22	AQUIFER TESTING (PUMPING)	8320				
	22A	Aquifer Step Test, includes cost of monitoring/recording equipment, data collection, analysis and reporting; minimum testing durations (hrs). 16 Pumping 24 Recovery		1	LS	\$10,000.00	\$10,000.00
	22B	Aquifer Constant Rate Test, inclds cost of monitoring/logging equipment, data collection, analysis and reporting; minimum testing durations (hrs). 72 Pumping 48 Recovery		1	LS	\$14,500.00	\$14,500.00
	22C	Water Quality Testing: includes cost of sampling materials, sample collection, shipping, analysis, and reporting.		1	LS	\$1,100.00	\$1,100.00
	22D	Discharge System (estimated) - includes settling basin if needed, flow valves, flow meters, sampling ports, discharge point protection, etc		1	LS	\$5,100.00	\$5,100.00
	22E	Power: all necessary generators, wiring, connections, controls, fuel, maintenance, rentals, etc. to install, develop, and test PW and OWS (as needed), Conduct Constant Rate Test.		1	LS	Included in 22A-22D	\$0.00
	23	DEMOBILIZATION	8320				
	23A	Demobilization: includes cost to demob drill rig, support equipment, removal of all equipment and materials, mob and demob of equipment necessary to rehabilitate/reclaim the site, abandon wells (as necessary), and site reclamation		1	LS	Included in Summary	\$0.00
	24	CONTRACT ADMINISTRATION	8320				
	24A	Contract Close-out: reports, logs, maintenance records and schedules, as-builts, etc.		1	LS	Included in Overheads	\$0.00
	24B	Meetings, site visits, debriefings, etc.		1	LS	Included in Overheads	\$0.00
SUBTOTAL THIS SHEET							\$30,700.00

QUANTITIES		PRICES	
BY W. Robert Talbot, 86-68320	CHECKED John Earle 11/30/2012	BY <i>[Signature]</i> Jim Jettor, P.E., C.C.E	CHECKED <i>[Signature]</i> 2/6/13
DATE PREPARED 11/29/12	PEER REVIEW / DATE Leslie Stone 12/04/2012	DATE PREPARED 02/05/13	PEER REVIEW / DATE Tom Hanks 2/6/13

FEATURE: San Joaquin River Restoration Program Friant Fish Hatchery Salmonid Conservation & Research Facility Alternative 1 - 20 cfs Bypass Pipeline		PROJECT: Central Valley Project - California	
Summary Sheet		WOID: A029F	ESTIMATE LEVEL: Appraisal
		REGION: MP	UNIT PRICE LEVEL: Oct-12
		FILE: H:\D8170\Common\JJetton\San Joaquin River Restoration Program\Friant Fish Hatchery Pipeline or Wells\Estimates\Alternative 2\SJRRP Friant Fish Hatchery Alt 2 02-05-2013.xlsx\Field Cost Summary Sht Template	

PLANT ACCOUNT	PAY ITEM	DESCRIPTION	CODE	QUANTITY	UNIT	UNIT PRICE	AMOUNT	
		Subtotal						
		Sheet 1	8140				\$3,894,600.00	
		Sheet 2	8140				\$18,578,410.00	
		Sheet 3	8140				\$13,581,980.00	
		Sheet 4	8140				\$6,308,760.00	
		Sheet 5	8450				\$397,000.00	
		Sheet 6	8430				\$436,000.00	
		Sheet 7	8420				\$109,781.00	
		Sheet 8 For 1 Well	8320	72	EA	\$178,975.00	\$12,886,200.00	
		Sheet 9 For 1 Well	8320	72	EA	\$30,700.00	\$2,210,400.00	
		Subtotal for 72 Wells					\$58,403,131.00	
		Mobilization	5%	+/-			\$2,900,000.00	
		Subtotal with Mobilization					\$61,303,131.00	
		Contract Cost Allowances (Sum of):	20%	+/-			\$12,696,869.00	
		Design Contingencies, 15 % (+/-)						
		APS, 5 % (+/-). Type of procurement: Request for Proposal (Assumed)						
		CONTRACT COST					\$74,000,000.00	
		Construction Contingencies	25%	+/-			\$18,000,000.00	
		FIELD COST (Unit Price Level Oct 2012)					\$92,000,000.00	
		Escalation to Notice to Proceed (NTP), from Unit Price Level (Oct 2012) to NTP (Oct 2015)					\$8,000,000.00	
			at	3.0%	per year for	3.00	years	
		FIELD COST (with Escalation to NTP, Price Level Oct 2015)					\$100,000,000.00	
		Non-Contract Costs				To be determined by the appropriate responsible office		
		CONSTRUCTION COST				To be determined by the appropriate responsible office		
		Ref.: For appropriate use and terminology, see Reclamation Manual, Directives and Standards FAC; 09-01, 09-02 and 09-03.						

QUANTITIES		PRICES	
BY See Previous	CHECKED See Previous	BY Jim Jetton, P.E., C.C.E.	CHECKED 2/5/13
DATE PREPARED See Previous	PEER REVIEW / DATE See Previous	DATE PREPARED 02/05/13	PEER REVIEW / DATE Tom Hanke 2/6/13

D. APPENDIX D – USBR DRAWING 40-D-6551

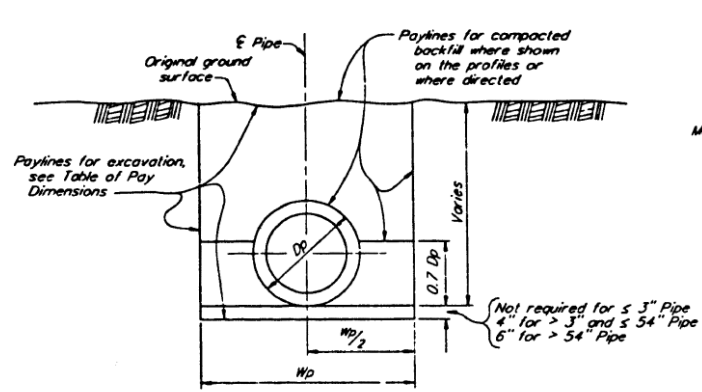

TRENCH FOR PAYLINES ONLY
ALL TYPES OF PIPE

TABLE OF PAY DIMENSIONS

Pipe I.D. (Inches)	Dp (Inches)	Wp (Feet)
6 and less	I.D. + 2	2.0
Over 6 thru 18	I.D. + 4	$\frac{1}{12}$ (I.D. + 24)
Over 18 thru 24	I.D. + 4	$\frac{1}{12}$ (I.D. + 40)
Over 24	1.167 I.D.	$\frac{1}{12}$ (1.167 I.D. + 36)

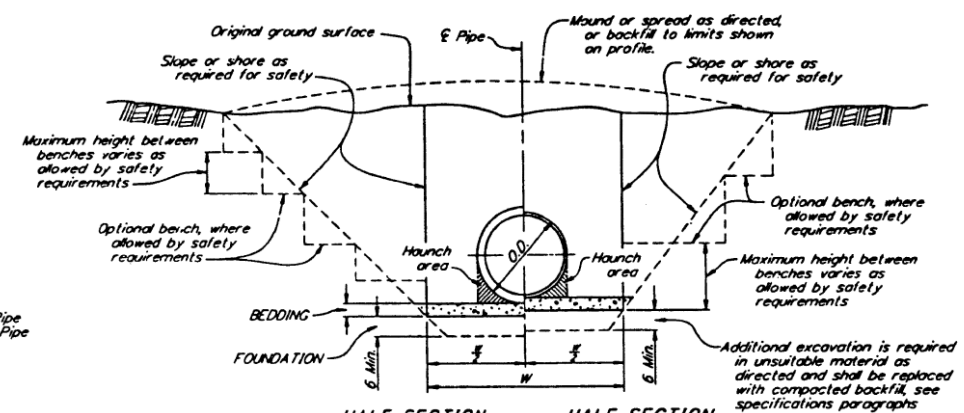

HALF SECTION RIGID PIPE
HALF SECTION FLEXIBLE PIPE
TYPICAL TRENCH DETAILS

MINIMUM INSTALLATION WIDTH

PIPE I.D. (INCHES)	W (FEET)
6 and less	2.0
Over 6 thru 18	$\frac{1}{12}$ (I.D. + 20)
Over 18	$\frac{1}{12}$ (I.D. + 36)

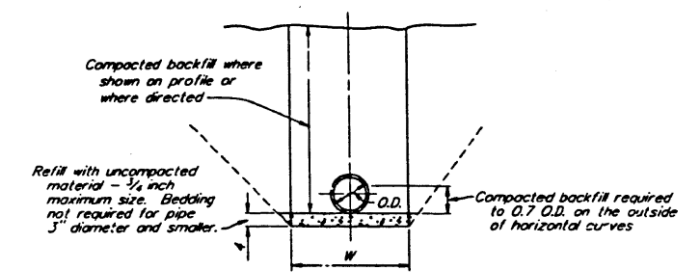

PIPE 10 INCH DIAMETER AND SMALLER

PVC
STEEL
DUCTILE IRON

GRADATION LIMITS FOR SELECT MATERIAL

SIZE #	PERCENT BY WEIGHT
Passing No. 200 sieve	5 or less
Passing No. 50 sieve	25 or less

* Maximum size shall not exceed $\frac{1}{2}$ inch.

NOTES

Dp and Wp are used for calculating pay quantities for all pipe and trench types. Calculations are based on vertical walls.
Paylines for backfill will be the paylines for excavation, except the volume of the pipe, based on the diameter Dp will be deducted, and except where the depth of backfill is limited as shown on profiles.
W is minimum width of excavation in feet at bottom of bedding. The minimum side clearance for flexible pipe may require a wider trench bottom than dimension W.
Pipe diameters shown are the nominal inside diameter (I.D.) of the pipe in inches unless otherwise indicated.
O.D. is outside diameter in inches of the pipe actually installed. Where pipe slope exceeds 0.3, see specifications paragraphs for backfill in pipe trenches.
Shoring, benching and benching shall be in accordance with Reclamation Construction Safety Standards.
Other installation methods with comparable pipe designs may be submitted for approval.

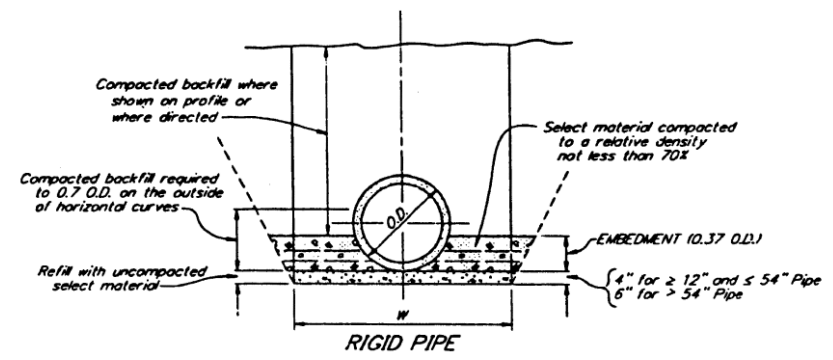

DUCTILE IRON ----- 12" - 20"
REINFORCED CONCRETE ----- 12" AND LARGER
REINFORCED CONCRETE CYLINDER ----- 48" AND LARGER

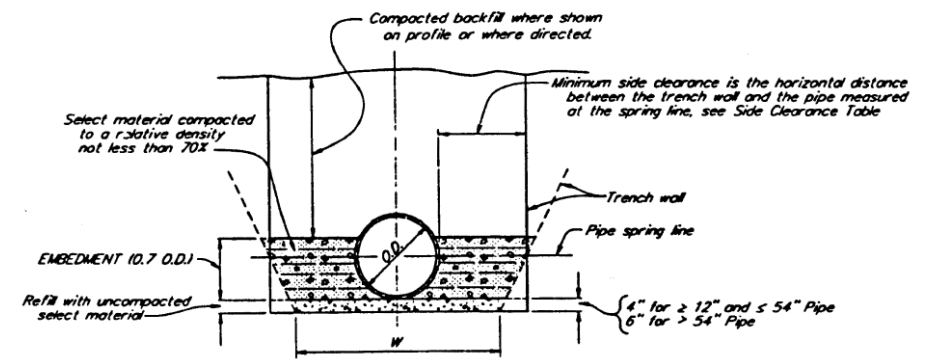

FLEXIBLE PIPE

PVC ----- 12" - 36"
PRETENSIONED CONCRETE CYLINDER ----- 12" - 66"
STEEL ----- 12" AND LARGER
FIBERGLASS ----- 12" AND LARGER
DUCTILE IRON ----- 24" AND LARGER

SIDE CLEARANCE TABLE

TRENCH TYPE	MINIMUM SIDE CLEARANCE (INCHES)
1	10 INCHES FOR 12" THRU 18" I.D. 18 INCHES FOR OVER 18" I.D.
2	ONE O.D.
3	TWO O.D.

For location of Trench Types, see Specifications.

11/31/91
D-10K
D-10K
D-10K

REMOVED NOTES ABOUT EQUAL LIFTS UNDER "RIGID PIPE" AND "FLEXIBLE PIPE".
REDRAWN WITH MINOR REVISIONS.

ALWAYS THINK SAFETY

UNITED STATES
DEPARTMENT OF THE INTERIOR
BUREAU OF RECLAMATION
STANDARD DESIGN

**PRESSURE PIPE
TRENCH INSTALLATION
SELECT MATERIAL**

DESIGNED: Richard T. Fuerst
DRAWN: Bob Scully
CHECKED: Leo A. Kinney, Jr.

TECHNICAL APPROVAL: Leo A. Kinney, Jr.
SUBMITTED: Douglas H. Wegener
APPROVED: W. L. Long

DATE: APR 1 1991
PROJECT: 40-D-6551