

## Appendix B

# Reports

### 2011 Draft Annual Technical Report





# Table of Contents

<b>1.0 Introduction .....</b>	<b>1</b>
<b>2.0 Juvenile Salmonid Survival and Migration (Preliminary Report).....</b>	<b>5</b>
<b>3.0 Thermal Tolerance Study .....</b>	<b>11</b>
<b>4.0 Reach 1A Bed Mobility Monitoring.....</b>	<b>15</b>
<b>5.0 Bed Mobility: Channel Bathymetric Surveys.....</b>	<b>18</b>
<b>6.0 Bed Mobility: Cross-Section Surveys .....</b>	<b>23</b>
<b>7.0 Bed Mobility: Scour Chains .....</b>	<b>25</b>
<b>8.0 Bed Mobility: Grain Size Data .....</b>	<b>27</b>
<b>9.0 Bed Mobility: Tracer Data.....</b>	<b>35</b>
<b>10.0 Bed Profile Surveys .....</b>	<b>38</b>
<b>11.0 Bed Sampling.....</b>	<b>43</b>
<b>12.0 Additional Water Level Recorders.....</b>	<b>48</b>
<b>13.0 Report: Water Surface Profile.....</b>	<b>54</b>
<b>14.0 Discharge Measurements .....</b>	<b>58</b>
<b>15.0 Topographic Surveys .....</b>	<b>64</b>
<b>16.0 Adult Passage Study .....</b>	<b>66</b>
<b>17.0 Fall-Run Captive Rearing Update .....</b>	<b>72</b>
<b>18.0 2010 Baseline Soil Salinity .....</b>	<b>77</b>

**19.0 1D Inundation Mapping ..... 107**

**20.0 Fish Passage Evaluation Task 1**

## Abbreviations and Acronyms

Act	San Joaquin River Restoration Settlement Act
ADCP	Acoustic Doppler Current Profiler
ATR	Annual Technical Report
CDEC	California Data Exchange Center
cfs	cubic feet per second
CSUF	California State University, Fresno
CVP	Central Valley Project
CVRWQCB	Central Valley Regional Water Quality Control Board
CTK	Cottonwood Creek
Delta	Sacramento-San Joaquin Delta
DFG	California Department of Fish and Game
DO	dissolved oxygen
DPR	California Department of Pesticide Regulations
DWR	California Department of Water Resources
FMP	Fisheries Management Plan
FMWG	Fisheries Management Work Group
FWUA	Friant Water Users Authority
GBP	Grasslands Bypass Project
GIS	graphical information systems
GRF	Gravelly Ford
GPS	global positioning system
HEC-RAS	Hydrologic Engineering Centers River Analysis System
LDC	Little Dry Creek
mg	milligram
MIL	Millerton Lake gaging station
mm	millimeters
NAD	North American Datum
N/L	nitrogen per liter
NMFS	National Marine Fisheries Service
NRDC	Natural Resources Defense Council
Order	State Water Resources Control Board Order WR-2009-0058-DWR
PVC	polyvinyl chloride
QA/QC	quality assurance/quality control
RA	Restoration Administrator
Reclamation	U.S. Department of the Interior, Bureau of Reclamation
RFID	radio frequency identification
RM	river mile

RTK	real-time kinematic
Secretary	Secretary of the U.S. Department of the Interior
Settlement	Stipulation of Settlement in NRDC, et al., v. Kirk Rodgers, et al.
SJR	San Joaquin River
SJRRP	San Joaquin River Restoration Program
SWAMP	Surface Water Ambient Monitoring Program
TMDL	total maximum daily load
USGS	U.S. Geological Survey
USFWS	U.S. Fish and Wildlife Service
WLR	water level recorder
WSE	water surface elevation
WY	Water Year

*This page left blank intentionally.*

# 1.0 Introduction

Reports summarize results from SJRRP studies and reference to the appropriate ATR Data Appendices. Reporting includes presentation of methods, data, interpretation, and describing applicability and limitations of results. This evaluation leads to recommendation of a management action, future reevaluation, or no further action. **Table 1-1** presents status updates for studies included in the 2011 Agency Plan.

**Table 1-1 Reporting for 2011 Agency Plan Studies**

2011 Agency Plan Appendix A Section	Study	Point of Contact/ Agency	ATR Section	Notes
2.0	Historical and Water Year Flow Gage Record Analysis	Katrina Harrison, Reclamation		In progress.
3.0	Flow Travel Time from Friant Dam and Tributaries to Gravelly Ford	Katrina Harrison, Reclamation		In progress.
4.0	Sediment and Hydraulics Monitoring and Analysis	Elaina Gordon, Reclamation	2010 ATR, Appendix B Section 15.0	
5.0	Lateral Gradient of Water Table	Stephen Lee, Reclamation		In progress.
6.0	Terrain Comparison Between Wells and Fields	Stephen Lee, Reclamation		Seepage Mgmt Plan, Appendix H
7.0	Changes in Salinity Conditions Resulting from Interim Flows	Joe Brummer, Reclamation	Draft 2011 ATR, Appendix B Section 18.0	
8.0	Flow Restrictions Due to Seasonal	Stephen Lee, Reclamation		Information under development in Seepage and Conveyance Technical Feedback Group



2011 Agency Plan Appendix A Section	Study	Point of Contact/ Agency	ATR Section	Notes
	Groundwater Conditions			
9.0	Monitoring Well Network Optimization	Katrina Harrison, Reclamation	Monitoring Well Atlas	
10.0	Surface Water Profile Surveys and Discharge Measurements	Dave Encinas, DWR	2010 ATR, Appendix B Section 5.0-6.0	
11.0	Monitoring Cross Section Resurveys	Dave Encinas, DWR	Draft 2011 ATR, Appendix B Section 6.0	
12.0	Effects of Sand Mobilization on High-Flow Water Surface Elevations	Dave Encinas, DWR	2010 ATR, Appendix B Attachment 1: Evaluation of Sand Storage, Supply, Transport in Reach 1A-1B TM	
13.0	Sand Storage in Reach 1	Dave Encinas, DWR	2010 ATR, Appendix B Section 10.0	
14.0	Additional Water-Level Recorders	Dave Encinas, DWR	2010 ATR, Appendix B Section 7.0	
15.0	Temperature Monitoring for Millerton Cold Water Pool	Erin Rice, Tracy Vermeyen, Reclamation	2010 ATR, Appendix B Section 2.0	
16.0	Evaluation of Law Enforcement Needs and Regulatory Changes to Limit Harvest	Eric Guzman, DFG		Revised study anticipated for 2012 MAP
17.0	Reach 1A Spawning Area Bed Mobility	Matt Meyers, DWR	Draft 2011 ATR, Appendix B Section 4.0-9.0; 2010 ATR Bed Sampling and Bed Mobility Reports, Appendix E	
18.0	Monitoring Spawning Gravel Quality and Quantity	Eric Guzman DFG	2010 ATR, Appendix B Section 3.0	

2011 Agency Plan Appendix A Section	Study	Point of Contact/ Agency	ATR Section	Notes
19.0	Effect of Scour and Deposition on Incubation Habitat in Reach 1A	Matt Meyers, DWR	Draft 2011 ATR, Appendix B Section 4.0-9.0; 2010 ATR Bed Sampling and Bed Mobility Reports, Appendix E	
20.0	Juvenile Salmonid Survival and Migration	Michelle Workman, USFWS	Draft 2011 ATR, Appendix B Section 2.0	
21.0	Floodplain Inundation	Katrina Harrison Reclamation	Draft 2011 ATR, Appendix B Section 19.0	
22.0	Water Quality Study	Chris Eacock, Reclamation	Appendix D in 2010 and Draft 2011 ATRs; 2010 ATR Appendix B Section 14.0 "Water Quality and Fish"	
23.0	Effect of Altered Flow Regime on Channel Morphology in Reach 1A	Matt Meyers, DWR	Draft 2011 ATR, Appendix B Section 4.0-9.0; 2010 ATR Bed Sampling and Bed Mobility Reports, Appendix E	
24.0	Temperature Monitoring for Adult Migration	Eric Guzman, DFG	2010 ATR, Appendix B, 4.0	
25.0	Adult Passage Study	Amanda Peisch, DWR	16.0 and Task 1 Draft TM	
26.0	Hyporheic pots	Eric Guzman, DFG; S. Mark Nelson, Reclamation		Data collection complete; report in progress.
27.0	Hills Ferry Barrier Evaluation	Matt Bigelow, DFG; Don Portz, Reclamation		Reclamation report is in review
28.0	Temperature modeling	Katrina Harrison, Reclamation		In progress.
29.0	Fall-run Chinook Experimental Captive Rearing Study	Paul Adelizi, DFG	Draft 2011 ATR, Appendix B Section 17.0	

<b>2011 Agency Plan Appendix A Section</b>	<b>Study</b>	<b>Point of Contact/ Agency</b>	<b>ATR Section</b>	<b>Notes</b>
30.0	Temperature Tolerance Study	Paul Adelizi, DFG	Draft 2011 ATR, Appendix B Section 3.0	
31.0	Benthic Macroinvertebrate SWAMP Bioassessment	Abimael León, DWR; Margarita Gordus, DFG	Main Body 2.9.7	
32.0	Egg Survival Study	Michelle Workman, FWS	Scheduled for September 2011	
33.0	Monitor Intragravel Dissolved Oxygen Concentrations in the San Joaquin River	S. Mark Nelson, Reclamation; Gregory Reed, Reclamation	Scheduled for September 2011	
N/A	Steelhead Monitoring Plan		N/A	WY2012 Interim Flows Supplemental EA, Appendix D

1

**Key:**

ATR = Annual Technical Report

DFG = California Department of Fish and Game

FMWG = Fisheries Management Working Group

GRF = Gravelly Ford

MIL = Friant Dam

Reclamation = U.S. Department of the Interior, Bureau of Reclamation

SJRRP = San Joaquin River Restoration Program

USFWS = U.S. Fish and Wildlife Service

WY = water year

# 2.0 Juvenile Salmonid Survival and Migration (Preliminary Report)

## 2.1 Introduction

The Fisheries Management Plan of the San Joaquin River Restoration Program (Program) (FMWG 2010) sets population goals for Chinook salmon (*Oncorhynchus tshawytscha*) to achieve the Restoration Goal for the Program. The Fisheries Implementation Plan (FIP) (FMWG 2010b) prioritized studies to address information needs to evaluate the Restoration Area for various fisheries needs. The FIP identified a study of juvenile salmonid migration and survival as a high priority for Interim Flows prior to the reintroduction of salmon which is required by the Stipulation of Settlement by December 31, 2012 (NRDC vs. Rodgers 2006). Study 20.0 in Appendix A of the 2011 Agency Plan for the San Joaquin River Restoration Program proposed a study utilizing acoustic telemetry to identify and characterize three limiting factors for juvenile Chinook survival through the Restoration Area: predation, entrainment, and physical habitat. Knowledge of these limiting factors will determine the best approach for initial reintroduction efforts, assist in developing habitat enhancement projects, and prioritize and recommend actions for the reduction or elimination of predation, entrainment and habitat impacts to survival.

The study was designed to provide information of survival of juvenile Chinook salmon during their spring downstream migration through the Restoration Area. Stationary telemetry receivers were deployed to assess survival through mining pits, at unscreened diversions, and in bypasses and river channel in all available reaches (1-5) of the Restoration Area.

Preliminary results of the first year of acoustic tracking of juvenile Chinook salmon is described in this report. At the time of submission, one final data download covering 2011 is still pending. A final report will be submitted in the December Monitoring and Assessment Plan.

## 2.2 Methods

- Receiver Deployment.** Receiver deployment planning was based on the following criteria: potential to address appropriate limiting factors (predation, entrainment, habitat), ability to access, and risk of vandalism. Receiver deployment followed the schedule and locations outlined in Table 1 below. Receivers were cabled to existing woody vegetation and/or structures available on the bank in chosen locations using 3/8 inch stainless steel cable. Concrete block anchors were used to weight the receivers, buoys were cabled to the anchors on approximately 3 feet of cable. The receiver was attached to the cable using hose clamps and suspended in the water column.

Table 1. Receiver Deployment Locations in the San Joaquin River Restoration Area

Date Deployed	Site Name	River Mile	Description
4/21/2011	Hatchery		
3/23/2011	Above Lost Lake - 1	265	above lost lake
3/23/2011	Above Lost Lake -2	265	above lost lake
3/24/2011	River Bend North Channel	260	upstream of first mine pits - split channel
4/6/2011	Vulcan Property	258	upstream of first mine pits - split channel
3/24/2011	Above Hwy 41-1	256	downstream of first mine pits
3/24/2011	Above Hwy 41-2	256	downstream of first mine pits
3/24/2011	Scout Island	250	downstream of second mine pits
4/4/2011	Pashyan Camp -1	234	downstream of third mine pits
4/4/2011	Pashyan Camp -2	234	downstream of third mine pits
4/13/2011	Gravelly Ford - 1	228	downstream of sixth mine pits and upstream of chowchilla
4/13/2011	Gravelly Ford - 2	228	downstream of sixth mine pits and upstream of chowchilla
4/12/2011	Downstream Chowchilla Bypass -1	214	downstream of chowchilla
4/12/2011	Downstream Chowchilla Bypass -2	214	downstream of chowchilla
4/19/2011	Columbia	205	above Mendota Pool
4/19/2011	MP1 (Mendota Pool)	205	diversion @MP
4/19/2011	MP2 (Mendota Pool)	205	diversion @MP
4/19/2011	JBP1 (Mendota Pool)	205	James Bypass diversion @MP
4/19/2011	JBP2 (Mendota Pool)	205	James Bypass diversion @MP
4/5/2011	MPDS-1	204	downstream of MP
4/5/2011	Chowchilla Bypass	216b	DFG lease in Chowchilla
4/13/2011	Sand Sloug - 1	169	ESB connection to river
4/13/2011	Sand Sloug - 2	169	ESB connection to river
4/18/2011	East Side SS1	169b	ESB at Sand Slough
4/18/2011	East Side SS2	169b	ESB at Sand Slough
4/15/2011	Mariposa Bypass	148mb	fish in mariposa
4/15/2011	East Side Bypass Up (Below Mariposa)	147eb	Mariposa Bypass
4/15/2011	East Side Bypass Down (Below Mariposa)	147eb	East Side Bypass
4/20/2011	HFB1 (Hills Ferry)	118	End of Restoration Area
4/20/2011	HFB2 (Hills Ferry)	118	End of Restoration Area

1

2

3 2. **Technology.** Specific acoustic technology for the study was based on a number of  
4 criteria. Size and battery length of transmitter was considered. Juvenile Chinook  
5 salmon pose a unique constraint in their small size at emigration from freshwater to  
6 the ocean. A number of companies produce transmitters sized to fit these small fish  
7 and have varying specifications regarding battery length, ping rate, detection range of  
8 receivers, and frequency of tag used. VEMCO VR2W-180khz receivers and V-6  
9 acoustic transmitters were used. VR2W-180 khz receivers have a detection range of  
10 approximately 75 m. V-6 tags weigh 0.65 grams in air and can be used on fish >  
11 13.0g, to adhere to a maximum of 5% body weight tag burden (Adams et al 1998).

12 3. **Source Fish.** Juvenile fall-run Chinook salmon from the Feather River Annex  
13 Facility were used in this study. Feather River fall-run are the earliest returning fall-  
14 run, and provided the best opportunity to get fish to the appropriate size for acoustic  
15 tracking at the earliest date. On April 6, 2011 staff from the California Department of  
16 Fish and Game and US Fish and Wildlife Service hand sorted approximately 1200  
17 fish from the Feather River Annex Facility using 19L (5 gallon) buckets and dip nets.  
18 Buckets were filled 1/2 full with raceway water. Fish were counted by groups of 25  
19 into the buckets and then hand carried to the transport tank and loaded into the tank.

1 The transport tank was filled with pumped water from the facility and temperature  
2 and dissolved oxygen were closely monitored. Dissolved oxygen was kept at or  
3 slightly above saturation. Fish were transported from the Feather River facility to the  
4 San Joaquin Interim Conservation Facility located at the San Joaquin River Hatchery  
5 complex in a 500 gallon double-walled insulated aluminum tank (Aquaneering INC,  
6 San Diego, CA) equipped with two mechanical aerators (Fresh-flo Corporation,  
7 Sheboygan, WI) and pure oxygen gas supplied from pressurized cylinders through  
8 two ceramic micro-bubble diffusers (Point Four Systems, Coquitlam, BC). Four  
9 mortalities were attributed to transport and handling stress.

10

11 4. **Surgery and Fish Release.** Fish were held in circular tanks with a flow through  
12 water system in the San Joaquin Interim Conservation Facility from April 6<sup>th</sup> to April  
13 18<sup>th</sup>. Fish tagging began on April 18<sup>th</sup>. All fish for tagging were anaesthetized using  
14 50 mg/L of tricaine methansulfonate (MS-222) for initial sedation and 15 mg/L for a  
15 maintenance solution during surgery. Fish were anaesthetized for 45 sec to 1 min  
16 max, then transferred to the maintenance solution for remainder of process. All fish  
17 were weighed, measured, adipose fin excised, and coded wire tagged. A subset of 200  
18 was surgically implanted with an acoustic transmitter. Transmitters were inserted  
19 through an approximate 1.5 cm incision into the peritoneal cavity of each fish just off  
20 the midline and anterior to the pelvic fins. The incision was made using a number 12  
21 surgical scalpel blade and closed with 2 - 3 interrupted stitches using 5-0 nylon  
22 braided sutures. Approximately 50-75 acoustic tags were placed each day, and 300  
23 coded wire tags implanted. Fish were tagged into 4 holding groups to provide two  
24 replicates for each release location. Approximately 250 coded wire tagged only fish  
25 and 50 acoustic tagged fish were held in four separate tanks. All fish were tagged by  
26 noon on April 20<sup>th</sup> and releases were conducted in the afternoon of the 21<sup>st</sup>, so all fish  
27 were held for a minimum of 24 hours and some a maximum of 3 days. All fish  
28 tolerated sedation, surgery and recovery well, and only one mortality occurred due to  
29 injuries suffered during netting. Two acoustic tagged fish from each replicate were  
30 held back in the interim facility to monitor long-term survival from surgery and  
31 assess true tag life compared to tag life rating provided by VEMCO. At the time of  
32 this report preparation (June 27, 2011), tags in the hatchery were still active.

33 5. **Receiver Downloads.** Each deployed receiver recorded the identification number and  
34 time stamp from the coded acoustic transmitters as tagged fish traveled within the  
35 detection range, estimated to be 75 m. Data were downloaded monthly in the field  
36 using a wireless personal computer interface. Data summaries were appended in the  
37 office after monthly downloads. Data collection is still ongoing.

38 6. **Data Summary.** Data from receiver downloads was transferred from Excel to MS  
39 Access for analysis. Detection data was summarized separately from Below Friant  
40 releases and San Mateo Crossing releases. Total number of fish making it to the end  
41 of the Restoration Area (Hills Ferry Barrier) was characterized by length of migration  
42 time and release group origin. Last detection location for individual fish was assessed  
43 as a determinant of survival-to- location. Data summary is incomplete as of this date

B-7- July 2011

1 as final downloads have not been conducted and receivers in the Mendota Pool area  
2 have not been downloaded to minimize access to the site. Data from these receivers  
3 will be downloaded when receivers are retrieved in late July 2011, once all  
4 transmitter batteries can be safely assumed to have expired. Detections from the  
5 receiver downstream of Mendota Pool are used as an assessment of survival through  
6 the pool, but retrieval from the Columbia Canal (above Mendota Pool) receiver will  
7 need to be downloaded to finalize that assessment. Preliminary data assessment  
8 compares the downstream of Chowchilla receiver (RM 214) to the below Mendota  
9 Pool receiver (RM 204)

## 10 **2.3 Results**

11 Preliminary results of acoustic tracking are separated into Below Friant Release and San  
12 Mateo Crossing Release.

13 Results of Below Friant (RM 266) Release include:

- 14 • 96 acoustic tagged fish were released in a group of 596 fish
- 15 • All acoustic tagged fish released Below Friant Dam were detected at least one  
16 time downstream of release.
- 17
- 18 • 46 fish from the Friant release group made it all the way to the end of the  
19 Restoration Area (Hills Ferry Barrier, RM 118)
- 20
- 21 • 39 fish were detected in the Chowchilla Bypass and 31 of these made it to HFB.
- 22
- 23 • Migration days from Friant Release (RM 266) to Hills Ferry Barrier (RM 118)  
24 ranged from 4-35 days and fish were detected in groups of 1-7 when detected.

25 Results of San Mateo Crossing (RM 212) releases include:

- 26 • 96 acoustic tagged fish were released in a group of 631 fish
- 27 • 31 of 96 acoustic tagged fish released at San Mateo Crossing were detected at  
28 least one time downstream of release (note: none of the receivers in and around  
29 Mendota Pool have been downloaded to date).
- 30 • 25 fish from the San Mateo Crossing Release group made it all the way to the end  
31 of the Restoration Area (HFB, RM 118).
- 32 • Migration days from San Mateo Crossing Release (RM 212) to Hills Ferry Barrier  
33 (RM 118) ranged from 3 days to 33 days, and fish were detected in groups of 1-7  
34 when detected.

35

36

## 1    **2.4    Discussion**

2    Seventy-one fish out of 192 acoustic tagged fish released ultimately made it out of the  
3    Restoration Area successfully. Fish migrated to Hills Ferry Barrier in as few as 3 days  
4    from San Mateo Crossing and 4 days from Below Friant. Maximum time to HFB  
5    preliminarily is 33 and 35 days respectively from San Mateo Crossing and Below Friant.  
6    More fish from the Below Friant Release were successful than the San Mateo Crossing  
7    release (46 v. 25).

8    This was the first year of a multi-year study. As such, detection resolution was better at  
9    some of the receiver locations than others. Even though 39 transmitters were detected in  
10   the Chowchilla Bypass, only two transmitters were detected at Gravelly Ford, the last  
11   receiver upstream of the bifurcation structure. Additionally, only 3 detections occurred at  
12   the below Chowchilla receiver in the river channel (RM 214), even though 46 fish made  
13   it to the end of the Restoration Area from the Below Friant Release. Better resolution of  
14   detections around the flow split between the bypass and river channel is needed to assess  
15   fish migration routes during flood flows.

16

## 17   **2.5    Conclusions and Recommendations**

18   Conclusions from this study would not be warranted at this time, since data collection is  
19   not complete. Conclusions will be provided when final reporting is complete. All data  
20   presented in this report are preliminary and subject to revision as a result of subsequent  
21   data collection and quality control/quality assurance procedures. Preliminary data  
22   assessment does provide the opportunity for the following recommendations:

- 23    • Some receiver locations should be moved to improve detection capabilities  
24    (Gravelly Ford, below Chowchilla)
- 25    • More receivers in the river between Mendota Pool and Sand Slough will help with  
26    resolution of results of survival and migration through those reaches.
- 27    • Additional receivers downstream of the Restoration Area and into the  
28    Sacramento-San Joaquin River Delta boundary will improve resolution of final  
29    disposition of tagged fish.
- 30    • Addition of mobile tracking between data downloads to increase resolution of  
31    data.

## 32   **2.6    References**

33   Adams NS, Rondorf D, Evans S, Kelly J, Perry R (1998) Effects of surgically and  
34   gastrically implanted radio transmitters on swimming performance and predator  
35   avoidance of juvenile Chinook salmon (*Oncorhynchus tshawytscha*). *Can J Fish Aquat.*  
36   *Sci.* 55:781–787



1 FMWG. 2010. Fisheries management Plan: a framework for adaptive management in the  
2 San Joaquin River Restoration Program. 147 pages plus appendices.

3 [FMWG]. 2010b. Fisheries Implementation Plan. Prepared for the San Joaquin River  
4 Restoration Program.

5 NRDC vs. Rodgers, et al. 2006. Stipulation of Settlement. 80pp.

6

# 1 **3.0 Thermal Tolerance Study**

## 2 **3.1 Introduction**

3 This study will test thermal tolerance of fall-run Chinook salmon in a controlled  
4 laboratory environment to evaluate gene expression under different thermal regimes.  
5 Experimentation using fall-run Chinook salmon will allow for investigation using non-  
6 ESA listed species prior to working with listed (spring-run Chinook salmon) species.  
7 This study will be conducted by the University of California Davis (UCD) Genomic  
8 Variation Laboratory.

9 Thermal tolerance is well-studied in Chinook salmon and is an important variable for  
10 fitness at various life stages. It is therefore a key factor to consider in a successful  
11 reintroduction program. This is particularly critical for the reintroduction of Chinook  
12 salmon to the San Joaquin system, the southernmost limit of the species' native range;  
13 great potential exists for climate change impacts to be felt early and severely in this  
14 portion of the range. Higher temperatures are known to directly affect salmonid growth  
15 and mortality, and to indirectly affect other variables such as behavior (e.g., habitat  
16 selection, swimming performance, relationship to prey-predator community  
17 structure),(Angilletta et al, 2008, Richter and Kolmes, 2005), all of which likely have  
18 some degree of genetic basis and heritability (Perry et al, 2001, Perry et al, 2005).  
19 Obtaining a gene expression profile of fall-run Chinook under variable thermal regimes  
20 will improve our understanding of the genetic basis of thermal tolerance in this run and  
21 other genetically similar runs such as spring-run Chinook. Specifically, genes with  
22 significantly different expression patterns at extreme thermal regimes in fall-run Chinook  
23 will enable a candidate gene approach to be undertaken for spring-run Chinook, which  
24 will increase study efficiency and lower sample sizes for this listed species. Gene  
25 expression patterns will be useful in understanding the mechanisms of response to heat  
26 shock and more importantly in monitoring and predicting changes in wild populations  
27 facing thermal stress (e.g., juveniles in the rewatered upper San Joaquin). Juveniles have  
28 been selected as the experimental life stage as they are biologically sensitive and likely to  
29 be present in-stream during the warmest times of year (Coutant, 1973).

## 30 **3.2 Methods**

31 The Thermal Tolerance study consists of two similar experiments, (1) thermal expression  
32 experiment, and (2) loss of equilibrium thermal expression experiment.

- 33 • For both experiments:
- 34 ○ All experimental activity conducted under an approved UC Davis Animal
  - 35 Care and Use protocol, and CDFG Scientific Collection permit.
  - 36 ○ Collect a total of 500 fertilized eggs from 10-20 different single pair fall-
  - 37 run Chinook matings (so that multiple families are represented in each

B-11- July 2011

- 1 temperature treatment) performed at Merced River hatchery as crosses are  
2 made. Fin clips from parents will also be taken at that time. All fin clips  
3 will be sent to the CDFG Tissue Archive.
- 4 ○ Keep families separated until individually tagged.
  - 5 ○ All rearing and experimentation performed at Academic Surge, UC Davis.
  - 6 ○ Incubate eggs and rear juveniles at a common acclimation temperature  
7 (12°C) prior to initiation of experiments.
- 8 • Thermal expression experiment:
    - 9 ○ Conduct three replicates of five temperature exposures (12, 15, 18, 21,  
10 25°C) for the experimental timeframe (3 hours) performed on juvenile  
11 Chinook. Exposures are followed by a 1 hour recovery period at the  
12 acclimation temperature.
    - 13 ○ Collect tissue from individuals, immediately after being euthanized, from  
14 each temperature treatment at relevant time points for use in gene  
15 expression analysis via RNAseq.
  - 16 • Loss of equilibrium thermal expression experiment:
    - 17 ○ Expose fish to a raising thermal regime, 6°C/hr from 12°C to 23°C.
    - 18 ○ Increase thermal regime to 0.5°C/30 minutes until the temperature reaches  
19 26°C.
    - 20 ○ During the thermal regime exposure, observe fish behavior for loss of  
21 equilibrium.
    - 22 ○ Once fish have lost equilibrium, immediately collect tissue from these  
23 individuals for use in gene expression analysis via RNAseq.

### 24 **3.3 Results**

25 This study is ongoing results are currently not available.

### 26 **3.4 Discussion**

27 Merced River Hatchery (MRH) fall-run Chinook salmon, brood year 2010, were used for  
28 this study. Merced River hatchery fish were preferred for this study as they are the  
29 Chinook population geographically closest to the reintroduction area. While studies  
30 suggest that California fall-run Chinook are genetically homogenous (Williamson and  
31 May 2005), slight genetic differences have been found between Merced River hatchery  
32 fall-run and other Central Valley fall-run (Garza et al. 2008). Additionally, there may be  
33 local adaptation that has not been detected with the limited number of markers used to  
34 study California Central Valley Chinook to date (Bekessy et al, 2002).

35 The temperature spread, in the Thermal Expression Experiment, is meant to approximate  
36 very low, medium and high temperature stress. One fish from each of the 11 families was  
37 included in each exposure group. Tissues collected include blood, gill, liver, muscle, and  
38 fin. The next steps are to isolate mRNA and proceed with RNAseq to obtain quantitative  
39 comparisons of genome-wide gene expression at these different temperature exposures.

1 The Loss of Equilibrium Expression experiment is designed to identify gene expression  
2 differences between more and less heat tolerant individuals from within a group of fish.  
3 A group of 110 fish composed of individuals from each of the 13 families was used. Loss  
4 of equilibrium was used as a physiologic time point at which to sample the fish. The first  
5 15 fish and the last 15 fish to lose equilibrium were sampled. Ten fish not exposed to any  
6 thermal regimes, and kept at 12°C, were sampled as a control. Tissue samples included  
7 blood, gill, liver, brain and muscle.

8 CDFG and UCD scientist assisted MRH staff during the spawning period, in order to  
9 collect a small number of eggs from different crosses. Eggs from 13 different crosses  
10 were collected and kept separate in incubation trays at the MRH. Eyed eggs were  
11 transferred from the MRH to the UCD Center for Aquatic Biology and Aquaculture  
12 Facility (CABA). Hatching occurred around late December 2010, and families were  
13 reared in separate tanks at CABA from January through March 2011. In April 2011  
14 families were tagged using visible implant elastomer tagging, and 11 families were  
15 pooled into 3 tanks for rearing in a common environment. Two out of the 13 families had  
16 insufficient numbers for the Thermal Expression Experiment, however, they were used in  
17 the Loss of Equilibrium Thermal Expression Experiment. In May 2011 the Thermal  
18 Expression Experiment. was conducted, and in June the Loss of Equilibrium Thermal  
19 Expression Experiment was conducted.

## 20 **3.5 Conclusions and Recommendations**

21 Studies are ongoing. It is pre-mature to make conclusions and recommendations at this  
22 time. However, a similar study may be repeated with spring-run fish, pending availability  
23 of fish and permitting, after 2012, using the candidate genes or the approach identified in  
24 the fall-run study.

## 25 **3.6 References**

- 26 Angilletta, MJ, EA Steel, KK Bartz, JG Kingsolver, MD Scheuerell, BR Beckman, LG  
27 Crosier. 2008. Big dams and salmon evolution: changes in thermal regimes and their  
28 potential evolutionary consequences. *Evolutionary Applications* 286-299.
- 29 Bekessy, SA, RA Ennos, MA Burgman, AC Newton, and PK Ades, 2002. Neutral DNA  
30 markers fail to detect genetic divergence in an ecologically important trait. *Biological*  
31 *Conservation*, 110:2, 267-275.
- 32
- 33 Coutant, C.C. 1973. Effect of thermal shock on vulnerability of juvenile salmonids to  
34 predation. *J. Fish. Res. Bd. Can.*, 30:965-973.
- 35
- 36 Garza, J. C., Blankenship, S. M., Lemaire, C. and Charrier, G. 2008. Genetic population  
37 structure of Chinook salmon (*Oncorhynchus tshawytscha*) in California's Central Valley.  
38 *CalFed Final Report*.

- 1 Perry, MPL, RG Danzmann, MM Ferguson, and JP Gibson. 2001. Quantitative trait loci  
2 for upper thermal tolerance in outbred strains of rainbow trout (*Oncorhynchus mykiss*).  
3 *Heredity*, 86: 333-341.  
4
- 5 Perry, MLP, CM Martyniuk, MM Ferguson, and RG Danzmann. 2005. Genetic  
6 parameters for upper thermal tolerance and growth-related traits in rainbow trout  
7 (*Oncorhynchus mykiss*). *Aquaculture*, 250: 120-128.  
8
- 9 Richter, A and SA Kolmes. 2005. Maximum Temperature Limits for Chinook, Coho, and  
10 Chum Salmon, and Steelhead Trout in the Pacific Northwest. *Reviews in Fisheries*  
11 *Science*, 13: 1: 23-49.  
12
- 13 Williamson, K. and B. May. 2005. Homogenization of fall-run chinook salmon gene  
14 pools in the Central Valley of California, USA. *N. Am. J. Fish. Man.* 25:993–1009.  
15

## 4.0 Reach 1A Bed Mobility Monitoring

### Introduction

In their Interim Flow Monitoring and Evaluation Recommendations (TAC 2009), the Technical Advisory Committee (TAC) recommended the following:

*Recommendation #26:* Field-based bed mobility studies should be initiated in Reach 1A to document flow thresholds that initiate movement of different bar surfaces during flood control releases, and Interim Flows and Restoration Flows (during wetter water years once channel capacity constraints have been removed).

Furthermore, the Fisheries Management Plan stated as Goal O the need to provide sufficient quantity and quality of spawning habitat for Chinook salmon (FMWG 2009).

Bed mobility is of importance to salmonids in that a periodically mobilized bed maintains a loose bed structure for spawning salmon and conditions conducive to embryo survival. Adequate ventilation is required for delivery of dissolved oxygen to incubating embryos and removal of their metabolic wastes. If fine sediment accumulates between gravel framework particles, ventilation of the subsurface is reduced. Therefore, by mobilizing the coarse surface layer of the bed the fine matrix can be flushed from the gravel interstices thereby increasing ventilation.

Hydraulic and sediment transport analyses by MEI (2008) indicate that the river bed in Reach 1A is immobile for the range of flows in the Settlement Agreement, but there is some local reworking of the bed at flows in the 1,000 to 8,000 cubic feet per second (cfs) range. The analysis specifically indicated that bed mobilization would occur at flows less than 3,500 cfs at some riffle clusters that exist in the upper part of Reach 1A between Friant Dam and Highway 41. As one of the goals of this work it is intended that the MEI (2008) analysis will be validated and if necessary refined using the results from this bed mobility study.

In order to assess the amount of gravel that is of sufficient quality and its ability to be maintained as suitable spawning gravel DWR has implemented a bed mobility study for upper Reach 1A of the San Joaquin River. An earlier draft of the study is located in the 2011 Agency Plan (Section 17), and a more detailed version of the study is presented in Draft 1 of the Annual Technical Report's Attachment A1: Bed Mobility Data Report (SJRRP 2010). The purpose of this study is to assess the mobility of the river bed in Reach 1A. The degree to which the bed is mobilized by pulse flows is anticipated to be low. Since mobilizing the bed is considered critical to the maintenance of spawning gravels future efforts to enhance the spawning habitat will require knowing:

- 1) The amount of area that is currently maintained by flushing flows;
- 2) The flows necessary to mobilize the native bed surface materials; and

1           3) The potential gravel sizes to use for anticipated spawning gravel  
2           augmentation.

3 The following data reports are included for this study:

- 4       • **Channel Bathymetric Surveys:** Channel topography was surveyed for building a  
5       topographic mesh for use with a flow and sediment transport model.
- 6       • **Channel Evolution Monitoring:** In order to validate a channel evolution model  
7       the channel geometry was monitored with repeat cross-sectional surveys of the  
8       channel. In addition, scour chains were installed to measure erosion and  
9       deposition associated with elevated flow events.
- 10      • **Grain Size Monitoring:** To analyze for grain size composition bulk samples  
11      were collected at bed locations sampled in 2008 as well as a new location along  
12      an eroding bank. The results from this analysis will be used to evaluate bed load  
13      supply, armoring, and channel evolution.
- 14      • **Tracer Monitoring:** RFID tagged tracer gravels were located and their position  
15      surveyed. Areas of tracer mobilization were observed and distance of travel  
16      measured. Future use of the tracer movement patterns will include validating a  
17      critical shear stress prediction, and a flow and sediment transport model.

18 The measurements associated with these tasks have been ongoing since summer 2007 and  
19 are described in this report. All data within the Data Appendix for this report are being  
20 presented for the first time.

## 21 **Conclusions and Recommendations**

22 Bed mobility appears to be limited within the study sites under flows as high as 7,080 cfs  
23 (CDWR 2011) that occurred in early January 2011. The following observations are based  
24 on incomplete analysis of data collected to-date and are preliminary.

- 25      ▪ Bar surfaces that are relatively higher in elevation are immobile under the  
26      monitored flow levels and therefore are not likely to:
  - 27           (1) Serve as high-quality salmon spawning habitat or
  - 28           (2) Provide a gravel supply to downstream areas.
- 29      ▪ Areas downstream of the riffle head and proximal to the thalweg appear to be the  
30      most mobile: experiencing mobility at bank full conditions (~1,700 cfs).
- 31      ▪ Other locations were mobile at low flows (i.e. 700 cfs) but were aided by large  
32      woody debris (LWD) that altered the hydraulic conditions within the vicinity.
- 33      ▪ Given the limited mobility that was observed since the original 2008 bulk samples  
34      were collected the negligible change in texture is expected.

35 A mobilized bed surface flushes the trapped, underlying fine material and therefore  
36 produces a coarsening of the subsurface. Samples were collected along the thalweg  
37 margins near locations where the flow velocity is increasing (e.g. head of riffles) under  
38 low flow conditions. The sampling location was limited by flow depth and velocity. So  
39 the areas experiencing the greatest mobility (e.g. thalweg) are not sampled. Still, the

B-16- July 2011

1 morphology (e.g. riffle head), flow depth (~2 ft) and velocity (~2 ft/s) of the locations  
2 sampled are typically sufficient for salmon spawning under low flows (~300 cfs).  
3 Therefore, the observed lack of textural change is believed to be representative of some  
4 of the most optimum salmon spawning habitat in the river.

5 Given the lack of mobility at the subject sites, which are believed to be two of the most  
6 mobile areas within upper Reach 1A (MEI 2008) we recommend:

- 7     ▪ Implementing alternatives to enhance and/or increase the amount and quality of  
8     suitable spawning gravels.
- 9     ▪ Continued monitoring of the recent 8,000 cfs flow.
- 10    ▪ Developing a flow and sediment transport model and calibrating and validating it  
11    with previously reported tracer, hydraulic, grain size, force gauge, and  
12    topographic data.
- 13    ▪ Expanding the validated flow and sediment transport model to other sites  
14    anticipated to have salmon spawning potential to predict the area of bed mobility  
15    and flushing maintenance.

## 16 **4.1 References**

17 CDWR. 2001. Department of Water Resources, California Data Exchange Center: San  
18 Joaquin River below Friant (SJF); Flow, river discharge, real time, provisional data.  
19 Retrieved from <http://cdec.water.ca.gov/>

20  
21 FMWG. 2009. Fisheries management plan: A framework for adaptive management in the  
22 San Joaquin River Restoration Program.

23  
24 Mussetter Engineering, Inc. 2008. DRAFT San Joaquin River Data Collection and  
25 Monitoring Plan, prepared for California Department of Water Resources, August 27, 31  
26 pp.

27  
28 SJRRP. 2010. 2010 Annual Technical Report, Draft 1, August 2010.

29  
30 TAC. 2009. San Joaquin River Restoration Program Interim Flow Monitoring and  
31 Evaluation Recommendations, prepared for San Joaquin River Restoration Program  
32 Restoration Administrator, February 2009.

33

34

35



1 **5.0 Bed Mobility: Channel Bathymetric**  
2 **Surveys**

3 The data in this report were collected as part of the Reach 1A Spawning Area Mobility  
4 Study (2011 Agency Plan Section 17). Channel topography was surveyed for building a  
5 topographic mesh for use with a flow and sediment transport model.

6 **5.1 Methods**

7 Two sites were selected for bed mobility measurements and monitoring activities  
8 (Figure 1). They are located at river miles (RM) 260.7 and 261.6 and are denoted as  
9 Riffle Clusters 38 (RC38) and 40 (RC40), respectively (MEI 2008). At each of these sites  
10 5 channel-spanning cross-sections were staked on both banks to stretch a tape measure  
11 across and define measurement locations. The cross-sections were selected to monitor  
12 and assess the upstream pool tail (XSA), riffle head (XS1), middle riffle (XS2), riffle tail  
13 (XS3), and downstream pool head (XS4) morphological zones (Figures 2 and 3).  
14

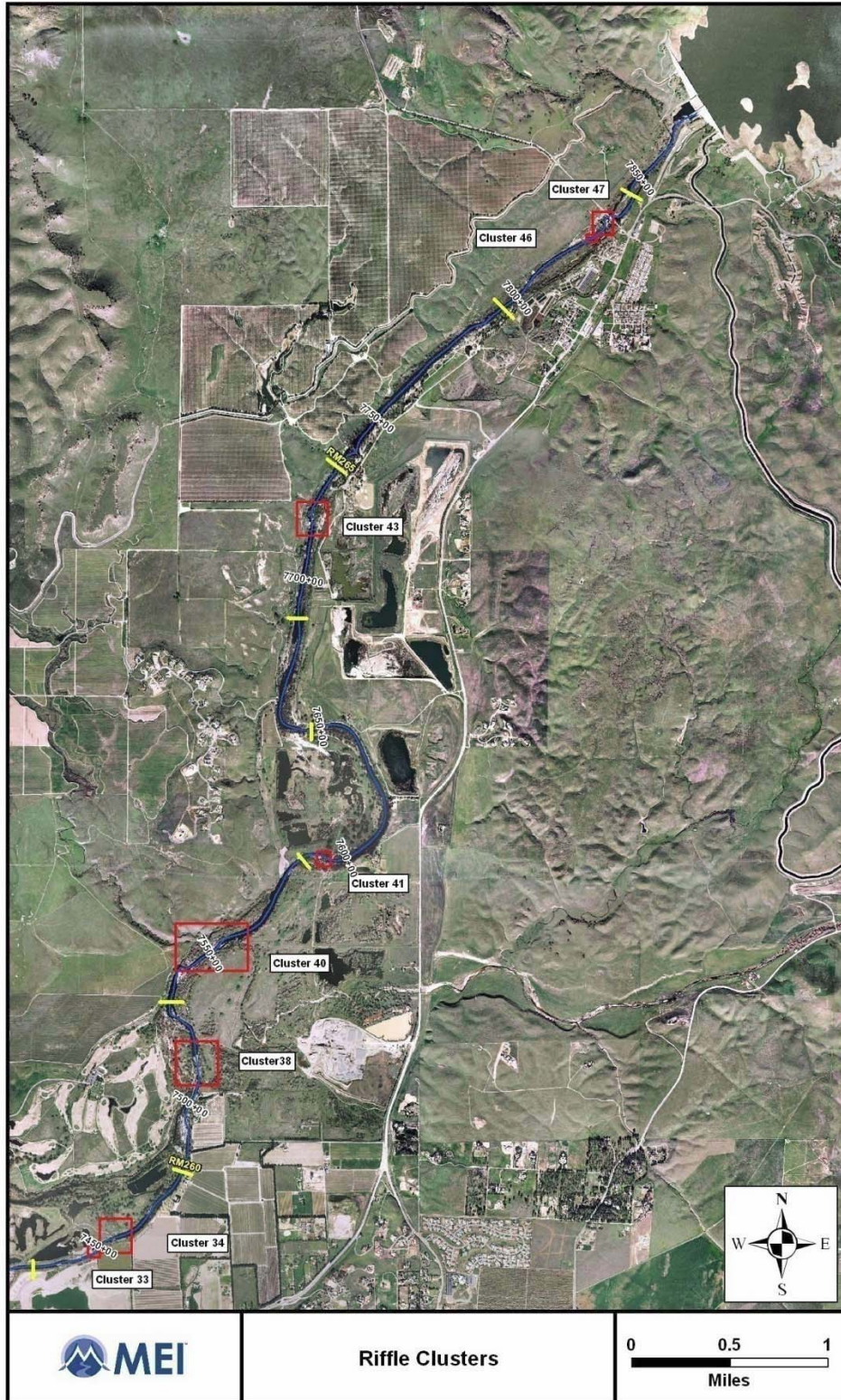

1  
 2 **Figure 5-1:** Riffle cluster areas where gravel mobilization studies were proposed. Sites  
 3 selected for this study are labeled Cluster 38 and Cluster 40 (Source: MEI 2008).

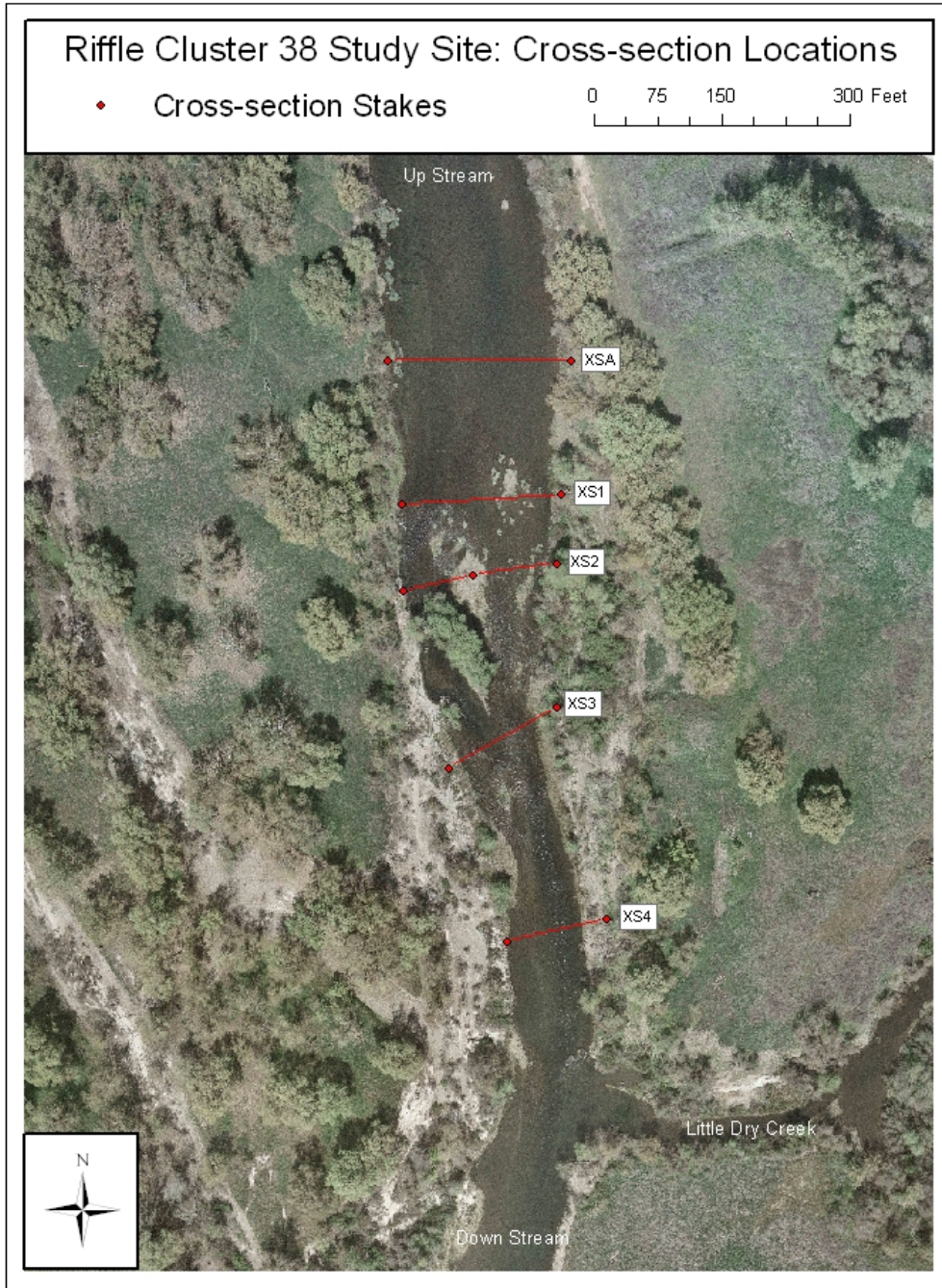

1  
 2 **Figure 5-2:** Riffle Cluster 38 study site's staked cross-sections XSA, XS1, XS2, XS3,  
 3 and XS4.



1  
 2 **Figure 5-3:** Riffle Cluster 40 study site's staked cross-sections XSA, XS1, XS2, XS3,  
 3 and XS4.  
 4

- 1 1. **Channel Bathymetric Surveys:** Ongoing surveys of the channel features were  
2 conducted for the purpose of developing a topographic mesh of the study sites. The  
3 topographic mesh will be used to develop a flow and sediment transport model.
- 4 a. **Topographic Surveys:** The topography in and around the channel was surveyed  
5 using a real-time kinematic (RTK) global position system (GPS) as the primary  
6 method of horizontally and vertically surveying the site. In situations where  
7 riparian canopy cover was too dense to maintain a satisfactory signal with GPS  
8 satellites a conventional total station and survey rod were used. All surveys are  
9 tied to the 2007/2008 established control points local to each study site. The  
10 horizontal datum used is the California Coordinate System Zone 3, US Survey  
11 Feet, based on California Geodetic Coordinates of 1983, Epoch 2007.0. The  
12 vertical datum used is the North American Vertical Datum of 1988. Established  
13 control points are presented in the 2010 Annual Technical Report. Existing  
14 control points are used to validate the accuracy of the data. At the commencement  
15 of a survey, several times per day, and at day's end the accuracy of the survey  
16 readings are verified by positioning the rover on a control point to make certain  
17 that the horizontal and vertical location is within 0.01 and 0.1 ft, respectively.  
18 Survey data presented with this report were collected from both study sites on  
19 September 2, 2010, December 2010 and February 2011.

## 20 **5.2 Results**

21 These data continue to be collected and should be complete for the final 2011 ATR.

## 22 **5.3 References**

23 Mussetter Engineering, Inc. 2008. DRAFT San Joaquin River Data Collection and  
24 Monitoring Plan, prepared for California Department of Water Resources, August 27, 31  
25 pp.  
26

27

## 1    **6.0    Bed Mobility: Cross-Section Surveys**

2    The data in this report were collected as part of the Reach 1A Spawning Area Mobility  
3    Study (2011 Agency Plan Section 17). In order to validate a channel evolution model the  
4    channel geometry was monitored with repeat cross-sectional surveys of the channel.

### 5    **6.1    Methods**

6    See the report titled “Bed Mobility: Channel Bathymetric Surveys” for information about  
7    location and configuration of the study sites.

- 8    1. **Channel Evolution Monitoring (Cross-Section Surveys):** Repeated cross-sectional  
9    surveys were performed to monitor change in bed elevation and location of the banks.  
10   Each monitoring event followed a high flow event such as the January 5, 2011 7,080  
11   cfs peak flow. Topography along monumented, channel spanning cross-sections was  
12   surveyed using a RTK GPS and methodology described under “Channel Bathymetric  
13   Surveys: Topographic Surveys” (Figure 4).



14

- 15   Figure 6-1: RTK GPS rover used while repeat surveying XS1 at RC38. The yellow tape  
16   is stretched between monument stakes on both banks and the rover rod is held plumb  
17   while placed tangential to the tape at each survey point.

## 6.2 Results

### Channel Evolution

Post Fall 2010 and January 2011 peak flow topographic survey results are illustrated and compared with previous surveys in the Data Appendix. A brief summary of the observations are as follows:

- RC38 XSA: No net change is observed.
- RC38 XS1: No net change is observed.
- RC38 XS2: No net change is observed.
- RC38 XS3: Approximately 1.0 ft of erosion along the left bank and 0.25 ft within the channel toward the right side of the channel is observed following the Fall 2011 event. A small amount of erosion (~0.25 ft) occurred from the January 2011 flow event which may have been the consequence of the large woody debris (LWD) that was removed from immediately upstream of the cross-section.
- RC38 XS4: No net change is observed.
- RC40 XSA: No net change is observed.
- RC40 XS1: Approximately 0.25 ft of erosion of the mid-channel bar following the Fall 2010 flow event. No net change after the January 2011 event.
- RC40 XS2: No net change is observed.
- RC40 XS3: A minor amount of erosion in the main channel and along the mid-channel bar following the Fall 2011 event. No net change after the January 2011 event.
- RC40 XS4: No net change is observed.

## 6.3 Discussion

### Channel Evolution

The channel geometry was predominantly stable with only minor erosion along small portions of the channel. Observed differences were typically on the order of a median grain diameter and are, therefore, considered within the error of the measurement. A larger amount of erosion was observed along RC38 XS3's right bank following the 700 cfs flow in Fall 2010. This was likely the result of the LWD upstream of XS3 deflecting flow and causing convergence in the vicinity of the right bank. Due to the relatively low discharge that produced that erosion and lack of significant erosion measured after much larger events it is suspected that the erosion is anomalous and this area should not be considered scour-able at such flow levels without the aid of flow perturbation.

# 1    **7.0    Bed Mobility: Scour Chains**

2    The data in this report were collected as part of the Reach 1A Spawning Area Mobility  
3    Study (2011 Agency Plan Section 17). In order to validate a channel evolution model  
4    scour chains were installed to measure erosion and deposition associated with elevated  
5    flow events.

## 6    **7.1    Methods**

7    See the report titled “Bed Mobility: Channel Bathymetric Surveys” for information about  
8    location and configuration of the study sites.

- 9
- 10    1. **Channel Evolution Monitoring (Scour Chains):** Scour chains were installed to  
11    measure erosion and deposition that occurs during elevated flow events. Scour chains  
12    were installed within 30 ft upstream of RC38’s XS2 and XS3 in February 2011. Due  
13    to limited time only six chains were installed, three at both cross-sections. These two  
14    cross-sections were selected due to past bed elevation changes. All other cross-  
15    sections have been stable. Each scour chain was hammered 2.5 to 3 ft in to the  
16    substrate, clasped with a hog ring at the link closest to the bed surface, surveyed with  
17    an RTK GPS, measured from the left bank monumented stake, and number of links  
18    exposed on the bed surface counted. Locations of scour chains are illustrated in  
19    Figure 5.

20





1  
 2 Figure 7-1: Scour chains locations at RC38. The first installation of scour chains were  
 3 placed along XS2 and XS3 due to previously observed erosion and deposition in these  
 4 areas.

## 5 **7.2 Results**

6 Chains were installed but have not been revisited yet due to high flows.

B-26- July 2011

1

## 2 **8.0 Bed Mobility: Grain Size Data**

3 The data in this report were collected as part of the Reach 1A Spawning Area Mobility  
4 Study (2011 Agency Plan Section 17). To analyze for grain size composition, bulk  
5 samples were collected at bed locations sampled in 2008 as well as a new location along  
6 an eroding bank. The results from this analysis will be used to evaluate bed load supply,  
7 armoring, and channel evolution.

### 8 **8.1 Methods**

9 See the report titled “Bed Mobility: Channel Bathymetric Surveys” for information about  
10 location and configuration of the study sites.

11 **1. Grain Size Monitoring:** Bulk samples were collected to determine the existing grain  
12 size composition and analyze for change by comparing with samples collected at the  
13 same locations in 2008 (DWR 2010). Additionally, bank samples were collected to  
14 estimate sediment supplied to the channel as a result of bank erosion. All samples  
15 were collected and surveyed at the end of February 2011.

16 a. **Bed Sampling:** Bulk samples of the bed were collected using a McNeil sampler  
17 (Figure 6) (McNeil & Ahnell 1964). At least two 5-gallon buckets worth of  
18 sediment were extracted from each location. The sample from each location was  
19 divided into two samples: a surface and a subsurface sample. The surface samples  
20 represent the coarse armor layer. They were sampled to a depth approximately  
21 equal to the surface’s largest particle’s intermediate diameter. The underlying  
22 sediment was then excavated until the McNeil sampler’s basin was in contact with  
23 the stream bed on all sides. This depth was typically about 25 to 30 mm below  
24 grade.



1

2 Figure 8-1: McNeil sampler used to collect a bed sample at RC38 location 14C  
3 approximately 20 ft upstream of XS3.

- 4       b. Bank Sampling: Bulk samples of the material making up the right bank, between  
5 XS2 and XS3, at RC38 were collected using a shovel, 5-gallon buckets, and  
6 measuring tape. The excavated sediment was divided into separate samples based  
7 on depth and type. Prior to sample collection the face of the bank was scraped  
8 clean of loose material. The *in situ* bank material was then discretized into 7-inch  
9 depths. A sample was carved out of the bank from its upper surface to a vertical  
10 depth of about 7 inches, another was collected from 7 to 14 inches, and a third  
11 from 14 to 21 inches. Each of these samples extended horizontally into the bank  
12 about 7 inches and filled 2/3 of a bucket. Finally, a similar volume of sediment  
13 was collected at the toe of the bank, representing the lag material. See Figure 7 for  
14 photos of the bank sampling.



1



2

3 Figure 8-2: The right bank at RC38 between XS2 and XS3 that is eroding during elevated  
4 flow events. Above is the bank near the sampling location. Below are the sample  
5 excavations for the bank (left) and the lag material at the toe of bank (right)

6 c. Location Survey: Each sample's location was surveyed using a RTK GPS using  
7 methodology described under "Channel Bathymetric Surveys: Topographic  
8 Surveys" above. See Figures 8 and 9 for sample locations at RC38 and RC40,  
9 respectively.

B-29- July 2011

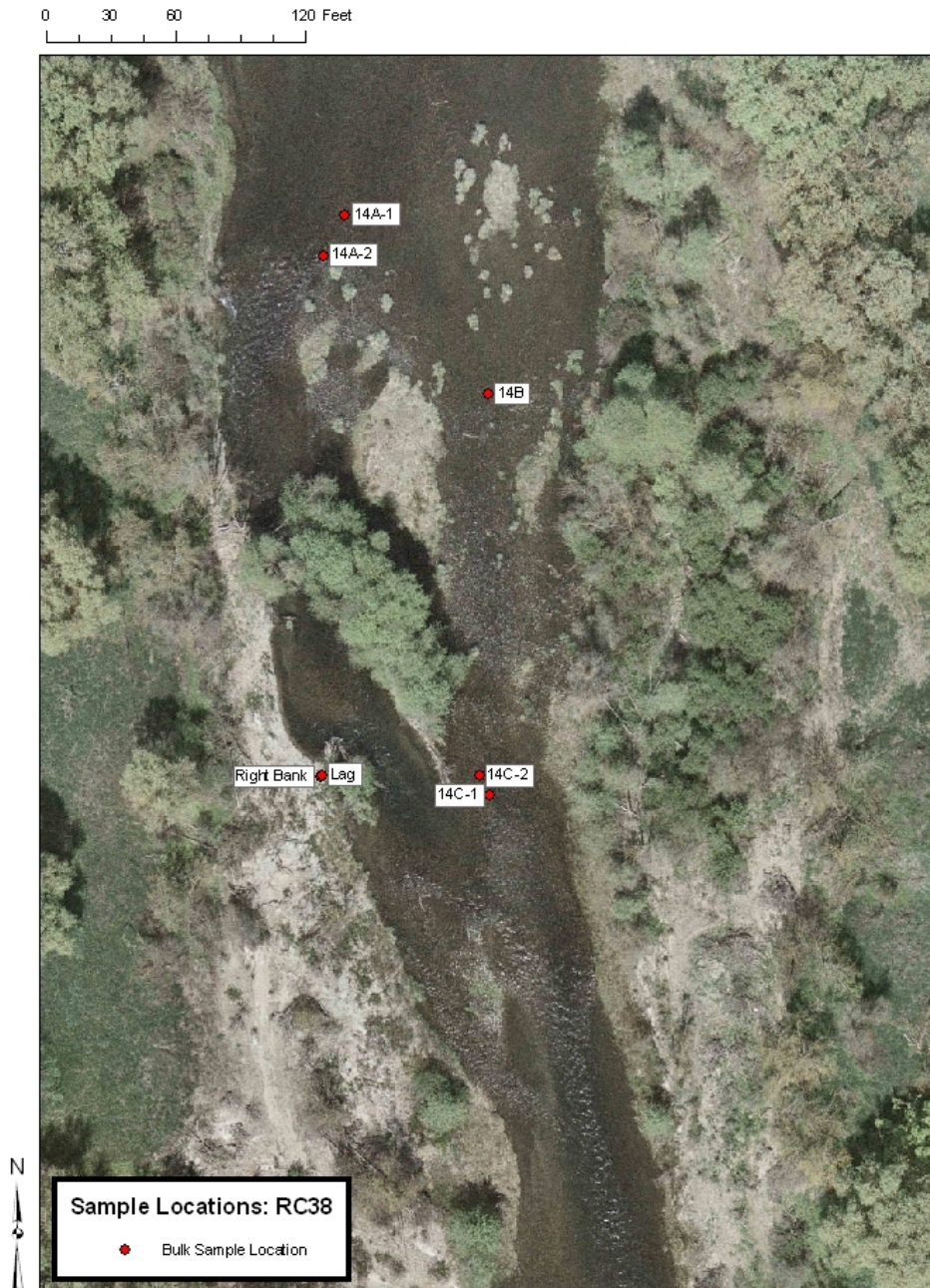

1  
 2 Figure 8-3: February 2011 sample locations at RC38. Samples 14A, B, and C are re-  
 3 sampled locations. Each of these sample locations was previously sampled in 2008.  
 4 Additional samples were collected on the right bank and the lag deposits along the right  
 5 bank. Note: the “Right Bank” and “Lag” sample locations are actually on the bank edge.  
 6 This aerial photo predates the erosion of the tree and bank to the east of these locations.

0 50 100 200 Feet



Figure 8-4: February 2011 sediment sample locations at RC40. Each of these sample locations was previously sampled in 2008.

B-31- July 2011

1 d. Sieving: Each sample had its coarser fraction sieved by manually shaking a stack  
2 of field sieves composed of 128 mm, 101.6 mm, 88.9 mm, 63.5 mm, 44.5 mm,  
3 31.8 mm, 22.2 mm, 15.9 mm, 11.1 mm, and 6.4 mm sieves. These coarse particles  
4 were weighed with a hanging scale and five gallon bucket to the nearest 100  
5 grams. The largest particle by weight of each sample was weighed using a digital  
6 scale to the nearest 0.1 grams for inspecting for influence on sample statistics by  
7 comparison with overall sample weight. The finer material (< 6.4 mm) was sieved  
8 in a laboratory shaker and sieves ranging from 5.6 mm to 0.063 mm in half phi  
9 intervals. These finer fractions were weighed using a digital scale to the nearest  
10 0.1 gram. Each sample was dried in an oven and sieved in its entirety.

## 11 **8.2 Results**

### 12 **Grain Size Analysis**

13 Grain size compositions are plotted as cumulative distributions for surface, subsurface,  
14 and undifferentiated bulk samples collected at RC38 and RC40 prior to the Interim Flows  
15 in Summer 2008 and after the January 2011 peak flow (Data Appendix). By comparing  
16 sample results at each location the 2011 samples are described relative to the 2008  
17 samples:

- 18     ▪ RC38 14A: Slightly finer surface with more medium gravel; slightly finer  
19     subsurface with more fine to medium sand; and slightly finer undifferentiated  
20     sample having relatively less cobble.
- 21     ▪ RC38 14B: Negligible change in all samples.
- 22     ▪ RC38 14C: Negligible change in the surface and subsurface being within the  
23     range of the duplicate sample error; negligible change in the undifferentiated  
24     sample with a slight increase in medium to coarse gravel.
- 25     ▪ RC40 11-1: Much coarser surface (most changed of all samples); negligible  
26     change in the subsurface; and an overall coarser undifferentiated sample.
- 27     ▪ RC40 11-2: Negligible change in the surface; and a finer subsurface and overall  
28     undifferentiated sample.
- 29     ▪ RC40 11-4: Coarser surface; much finer subsurface; and an overall finer  
30     undifferentiated sample.
- 31     ▪ RC40 12: Negligible to slightly finer surface; finer with an increase in coarse sand  
32     to fine gravel in the subsurface; and an overall finer undifferentiated sample.

## 33 **8.3 Discussion**

### 34 **Bed Textural Change**

35 Comparison of samples collected before and since Interim Flows suggest localized  
36 change. Differences between samples at RC38 were negligible. However, differences  
37 between RC40's samples 11-1 and 11-4 were significantly coarser and finer, respectively.  
Reports  
Appendix

1       ▪ Sample 11-1's surface was measured to be much coarser, while the subsurface  
2       remained unchanged.

3       ▪ Sample 11-4's surface was measured to be finer but the subsurface had  
4       significantly more sand sized material.

5       Due to the difficulty in capturing the sand sized component, especially in the surface  
6       layer sample, the combined samples (i.e. the undifferentiated sample) results should be  
7       evaluated to see if the surface sand may have instead been captured in the lower sample.

8       ▪ The combined surface and subsurface results in a coarser overall sample for the  
9       11-1 sample with a decrease in the sand and fine gravel content.

10      ▪ The combined surface and subsurface results in a finer overall sample for the 11-4  
11      sample with an increase in coarse sand and fine gravel content.

12      ▪ The combined surface and subsurface results for the remainder of the samples  
13      show remarkably little change and appear to be within the sampling error as  
14      indicated by the range in the duplicate sample's (14A-1, 14A-2; and 14C-1,  
15      14C-2) CDF curves.

16      Greater variation can be seen between the differentiated samples. This is most likely the  
17      result of sample size. As the sample becomes larger it is more likely to better represent  
18      the population. For this reason there is greater difference between the surface samples;  
19      meaning the surface sample is the smallest. In addition, the surface samples are coarser  
20      and the presence or absence of a larger particle can make a significant difference.  
21      Generally, samples should be sampled such that no one particle exceeds 5% of the  
22      sample weight. Among our samples few met this criteria:

23      ▪ The subsurface and undifferentiated samples for 14A when two duplicate samples  
24      are combined.

25      ▪ The subsurface and undifferentiated samples for 14C-2.

26      All the surface samples' largest particles were 16 to 37% of the sample weight; indicating  
27      a need for three to four times the sample mass to overcome the associated error. The  
28      other subsurface samples had percentages below 19%; while the other undifferentiated  
29      samples had percentages less than 14%. The bank samples faired better with the 0 to 7.5  
30      inch and 7.5 to 14 inch samples at 5% or less; while both the 14 to 21 inch and Lag  
31      samples had the largest particle take up 8% of the sample weight. Therefore, those  
32      samples with larger percentages should be interpreted with caution.

## 33      **8.4   References**

34      DWR. 2010. DWR 2009 Interim Flows Data Report DRAFT, 3/26/2010, Appendix IV:  
35      San Joaquin River Riffle Particle Size Composition Survey Interim Report, River Miles  
36      247 – 267, Final Draft, 3/17/2010.

37

38      McNeil, W. J. and W. H. Ahnell. 1964. Success of pink salmon spawning relative to size  
39      of spawning bed materials. US Fish and Wildlife Service Special Scientific



1 Report, Fisheries No. 469.

2

## 1    **9.0    Bed Mobility: Tracer Data**

2    The data in this report were collected as part of the Reach 1A Spawning Area Mobility  
3    Study (2011 Agency Plan Section 17). RFID tagged tracer gravels were located and their  
4    position surveyed. Areas of tracer mobilization were observed and distance of travel  
5    measured. Future use of the tracer movement patterns will include validating a critical  
6    shear stress prediction, and a flow and sediment transport model.

### 7    **9.1    Methods**

8    See the report titled “Bed Mobility: Channel Bathymetric Surveys” for information about  
9    location and configuration of the study sites.

10   **1. Tracer Monitoring:** Gravel and cobbles fitted with radio frequency identification  
11    (RFID) tags were located and surveyed. In addition, new tracers were placed where  
12    previous tracers mobilized.

13    a. Tracer Locating: Tracers were located both visually and using a radio antenna. In  
14    order to determine the identity of each tracer the radio antenna and a reader were  
15    used that reads the code from the RFID tags when the antenna is hovered above  
16    the tracer. Upon locating each tracer several notes were taken including: its  
17    orientation relative to the flow direction and perpendicular to the bed surface,  
18    depth of burial under coarse sediment, percent embeddedness in fine sediment,  
19    relationship with neighboring particles (e.g. clustered, imbricated, loosely  
20    exposed, embedded, or pocketed), and, if near a cross-section, its distance from  
21    the left bank stake. All tracers were left in place for future monitoring unless its  
22    position appeared to be compromised by human interference or its RFID was  
23    missing/broken. Tracer surveys were performed at all cross-sections at both study  
24    sites in February 2011.

25    b. Tracer Installation: New tracers were constructed of gravel and cobbles collected  
26    from the two study sites. Each tracer was (1) drilled, (2) fitted with a RFID tag,  
27    (3) painted, and (4) recorded for weight, three dimensional axes, roundness, size  
28    class, and RFID code. After tracer locating was performed (see above) mobilized  
29    tracers along the cross-section were noted and later replaced with a new tracer.  
30    Each tracer’s placement was done such that it replaced an *in situ* particle of  
31    similar size and shape and placed so as to mimic its orientation and relationship  
32    with neighboring particles. While installing each new tracer its orientation,  
33    relationship with neighboring particles, and distance from left bank stake were  
34    recorded.

- 1 c. GPS Surveying: Upon locating or placing each tracer its position was surveyed  
2 using an RTK GPS as above. Tracer GPS surveys were performed in February  
3 2011.
- 4 d. Mobilization Analysis: Each located particle was compared with the last location  
5 in which it was surveyed. The before and after easting and northing coordinates  
6 were used to calculate the distance traveled.

## 7 **9.2 Results**

### 8 **Tracer Monitoring**

9 To better illustrate the tracer travel patterns each mobilized tracer was connected with a  
10 line to its previous surveyed location. Results following each elevated flow event since  
11 tracer deployment are presented in the Data Appendix. Tracer survey results after each  
12 elevated flow event are summarized below:

- 13 1) Spring 2010 Peak Flow of 1,700 cfs:
- 14 RC38 XS1: Minor mobility along thalweg.
- 15 RC38 XS2: Some significant mobility along thalweg including 128 mm  
16 tracers.
- 17 RC38 XS3: Significant mobility along thalweg including 128 mm tracers.
- 18 2) Fall 2010 Peak Flow of 700 cfs:
- 19 RC38 XSA: Negligible mobility.
- 20 RC38 XS1: Some mobility along thalweg including 128 mm tracer; scoured  
21 area develops downstream of XS1 along right bank.
- 22 RC38 XS2: Some significant mobility along thalweg including 45 mm tracers.
- 23 RC38 XS3: Significant mobility along thalweg including 64 mm tracers; may  
24 be influenced by large woody debris (LWD) pile upstream of XS3 by about  
25 30 ft.
- 26 RC38 XS4: Negligible mobility.
- 27 RC40 XSA, XS1, XS2, XS3, XS4: Negligible mobility (only 64, 90, 128 mm  
28 tracers).
- 29 3) January 2011 Peak Flow of 7,080 cfs:
- 30 RC38 XSA: Negligible mobility.
- 31 RC38 XS1: Some mobility along thalweg including 128 mm tracers;  
32 negligible mobility at head of bar.
- 33 RC38 XS2: Some significant mobility along thalweg including 90 mm tracers;  
34 negligible mobility on bar.

- 1 RC38 XS3: Significant mobility along thalweg including 128 mm tracers;  
2 may be influenced by removal of LWD by high flows; left channel area  
3 significantly less mobility.
- 4 RC38 XS4: Significant mobility up to 90 mm tracers.
- 5 RC40 XSA: Negligible mobility.
- 6 RC40 XS1: Negligible mobility.
- 7 RC40 XS2: Minor mobility of up to 90 mm tracers along a small ~25 ft wide  
8 section.
- 9 RC40 XS3: Negligible mobility.
- 10 RC40 XS4: Moderate mobility of up to 90 mm tracers.

## 11 **9.3 Discussion**

### 12 **Tracer Mobility**

13 Tracer mobility monitoring results suggest localized mobility under even the highest  
14 flows monitored to date.

- 15     ▪ The pool tail cross-sections (XSA) at both study sites experienced negligible  
16 mobility.
- 17     ▪ Riffle head cross-sections (XS1) experienced negligible to limited mobility with  
18 the thalweg area at RC38 having the most mobility and the bar being stable.
- 19     ▪ Mid-riffle cross-sections (XS2) experienced similar mobility patterns as XS1 but  
20 generally greater amount of particles mobilized were it occurred.
- 21     ▪ Riffle tail cross-sections (XS3) were variable. RC40 had a stable bed under all  
22 flows monitored. RC38 had the greatest amount of mobility amongst all cross-  
23 sections. This result may have been influenced by the LWD occurrence but was  
24 not likely the sole result of it. Previous pilot tracer results suggest this area to be  
25 mobile under moderate flow conditions without the aid of flow perturbation.
- 26     ▪ Pool head cross-sections exhibited significant mobility under the highest flows  
27 and stability otherwise.
- 28     ▪ Tracer travel distances did not reach the downstream riffle but instead deposit in  
29 the downstream pool to pool tail region.

30

# 1 **10.0 Bed Profile Surveys**

## 2 **10.1 Introduction**

3 The data presented in this report are related to the study “Effects of Sand Mobilization on  
4 Water Surface Elevation” that specifically addresses needs related to Problem Statement  
5 5 in the 2011 Agency Plan, San Joaquin River Channel Capacity Management. Resulting  
6 data will be used to evaluate the changes in bed formation and to create stage-discharge  
7 rating curves to assess the extent to which potential bed mobilization affects channel  
8 capacity.  
9

10 Two monitoring sites in Reach 2A were selected for this task and one cross section per  
11 each site was monumented. Cross sectional and longitudinal profiles at the selected cross  
12 section sites were repeatedly surveyed during one release event in January 2011. During  
13 the survey, a discharge measurement along with multiple water surface elevation  
14 measurements was also made.

## 15 **10.2 Methods**

### 16 **10.2.1 Site Selection**

17 The locations for the data collection sites were selected based on the previously  
18 established Vegetation Monitoring Sites M6.5 (River Mile (RM) 223.8) and M10 (RM  
19 219.8) in Reach 2A. The locations of the selected cross sections are shown in Figure 1.

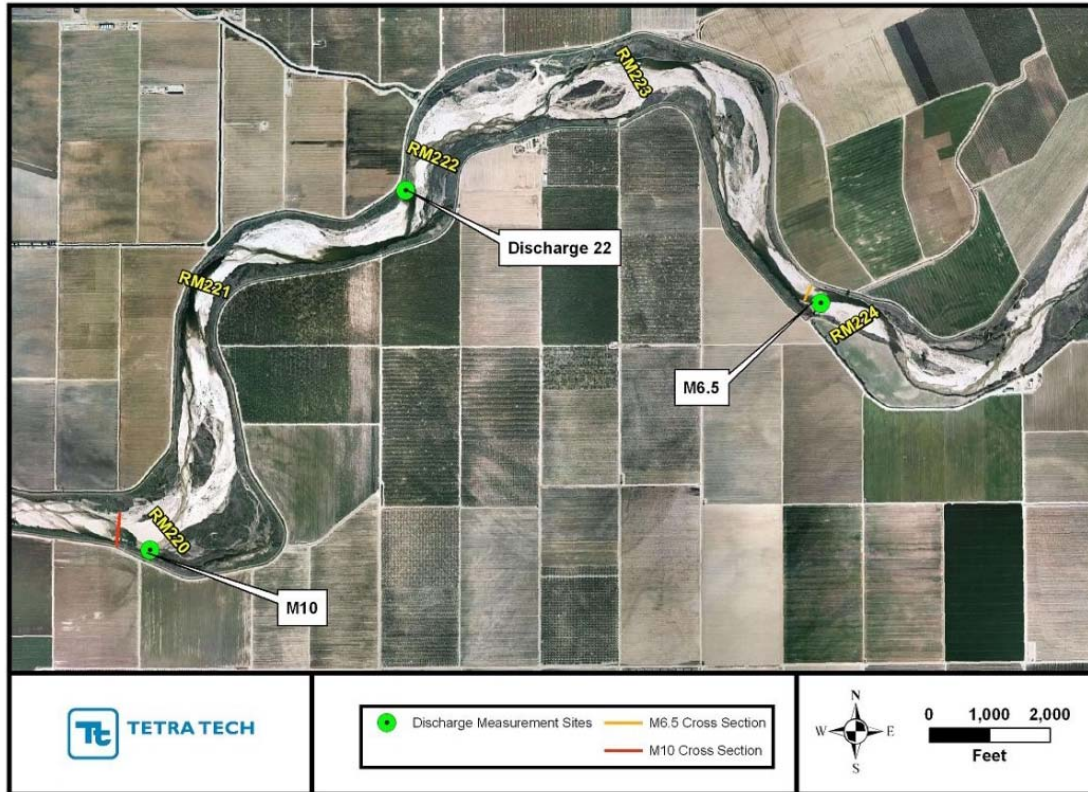

Figure 10-1. General Location of Monitoring Sites M6.5 and M10

### 10.2.2 Monitoring Activity

In January 2011, the bed profile survey was performed in M6.5 for the flood flow release of 6,000cfs from Friant Dam. The discharge was measured with DWR’s TRDI Rio Grande ADCP and bed profile was measured using a cataraft mounted echo sounder linked to survey-grade GPS rover. Detailed methodologies of this monitoring task were described in 2010 ATR.

### 10.3 Results

Bed profile surveys were performed during five interim flow release benches from Friant Dam in 2010 that ranged from 800 to 1,550cfs and the associated data was presented in the 2010 ATR. Results of the survey performed in January 2011 are compared with previous data and presented below.

The comparisons of plan and profile views of thalwegs at Site M6.5 for various flow release benches that occurred in 2010 along with the Friant release of 6,000cfs that occurred early in 2011 are presented in Figure 2 and Figure 3. The measured discharge at Site M6.5 was 4,480cfs on January 10, 2011. The comparisons of cross-sectional profiles and the respective plan views for Site M6.5 are shown in Appendix D.

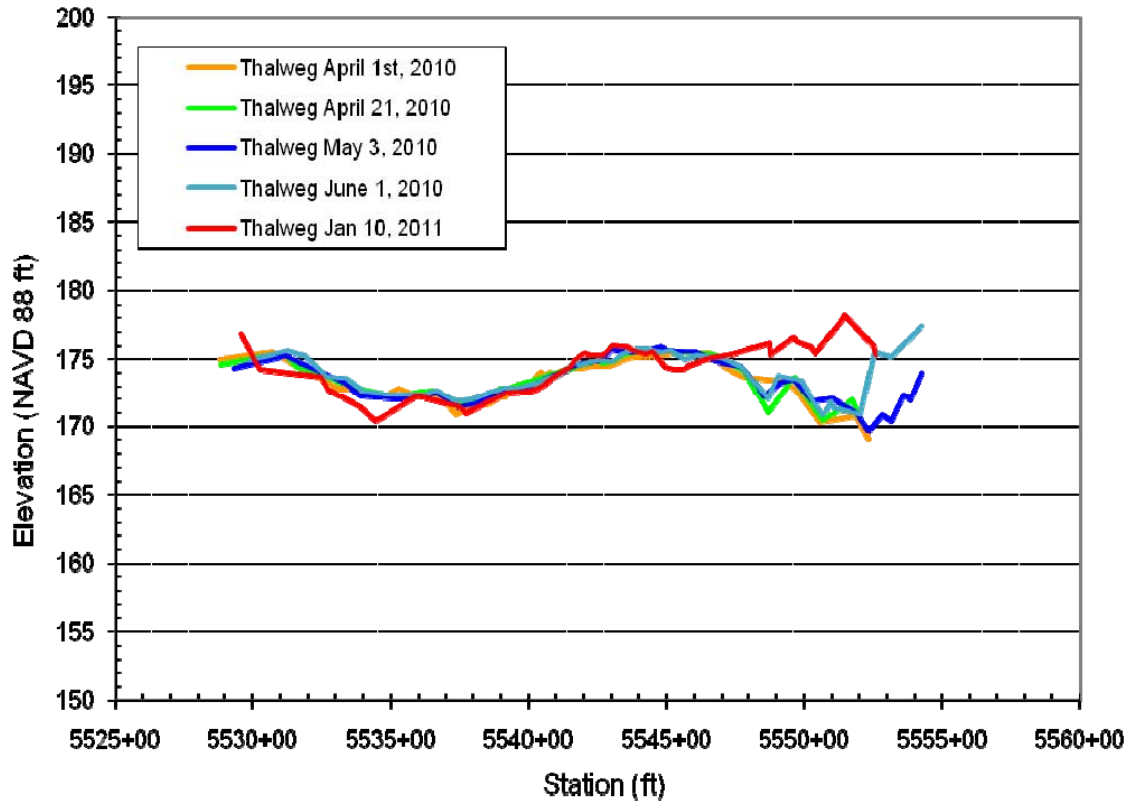

1  
2  
3  
4  
5

Figure 10-2. Profile View of the Thalweg during the spring 2010 and 2011 bathymetric surveys at M6.5

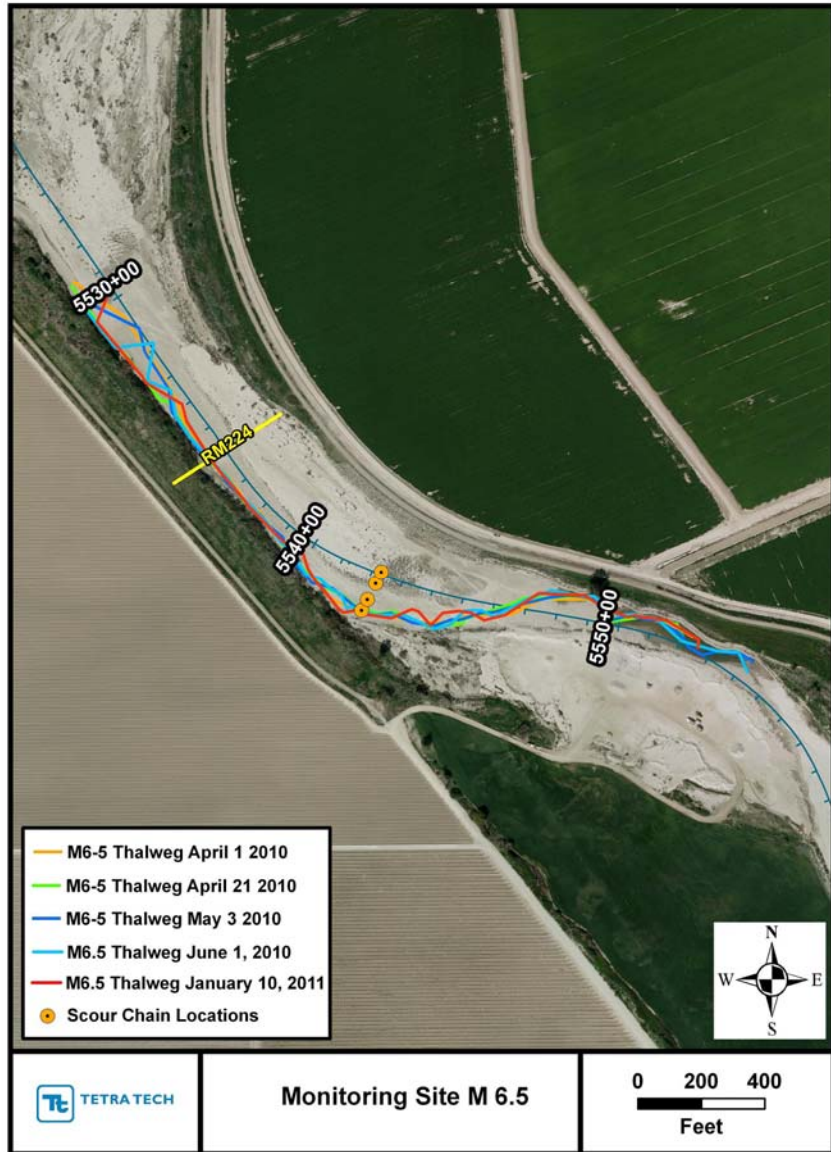

1  
2  
3

Figure 10-3. Plan View Showing the Location of the Thalweg during the spring 2010 and 2011 bathymetric surveys at M6.5

4 **10.4 Discussion**

5 In general, comparison of the bed elevation data shows that very little change in bed  
6 elevations or horizontal locations of thalweg occurred at Site M6.5 over the range of  
7 surveyed flows (Figure 2 and Figure 3). Some deposition occurred in the pool on river  
8 right (north) at the upstream end of the survey area at Site M6.5 between River Stations  
9 5547+34 and 5552+48 between June 1, 2010 and January 10, 2011 (Figure 2). Deposition  
10 was observed at the same vicinity (between Sta. 5545+52 and 5554+25) between May 3  
11 and June 1, 2010 also. The deposition might have occurred due to localized bed material  
12 movement from sand bar on river left (south) during the higher flood flow release. It is



1 not known whether the formation of this sand bar in early spring 2010 was due to natural  
2 behavior of the river or any possible human activities.

3  
4 Analysis of the data collected in January 2011 is not complete. The final 2011 ATR will  
5 include analysis results that should help determine the impact of bed mobilization on  
6 water surface in this area.

## 7 **10.5 Conclusions and Recommendations**

8 General scour was not observed over the range of surveyed flows (800cfs to 6,000cfs).  
9 Local scour and deposition was observed at the sites but human influences at Sites M6.5  
10 and M10 make it very difficult to measure general scour at these locations. The final  
11 2011 ATR will include conclusions regarding the success of this study to-date, whether  
12 the study should be continued, and whether any adjustments to site location or methods  
13 should be made.

14  
15 Water surface elevation data that were collected during the bed profile survey should be  
16 compared with HEC-RAS model predicted water surface elevation data. The Reach 2A  
17 data that were collected from the above two sites should further be analyzed to evaluate  
18 general trends in aggradation and degradation.

## 19 **10.6 References**

20 Powell, D.M., R. Brazier, J. Wainwright, A. Parsons and M. Nichols, 2006. Spatial  
21 patterns of scour and fill in dryland sand bed streams, *Water Resources Research*, v42,  
22 W08412, pp 1-11.

23  
24 Harvey, M.D. and Watson, C.C., 1988. Channel response to grade control structures on  
25 Muddy Creek, Mississippi. *Regulated Rivers, Research and Management*, v.2, 79-92.

26  
27 Foley, M.G., 1975. Scour and fill in ephemeral streams, W.M. Keck Laboratory of  
28 Hydraulics and Water Resources, California Institute of Technology, Report No. KH-R-  
29 33, 202 pp.

30  
31 Culbertson, J.K. and Dawdy, D.R., 1964. A study of fluvial characteristics and hydraulic  
32 variables, Middle Rio Grande, New Mexico. US Geological Survey Water Supply Paper  
33 1498-F, 74p.

34

# 1 **11.0 Bed Sampling**

## 2 **11.1 Introduction**

3 Data discussed in this report were collected as a part of the Channel Capacity  
4 Management study, Monitoring Cross Sections Re-surveys (2011 Agency Plan Section  
5 11) which expands on the monitoring plan from Mussetter Engineering (2008). This  
6 monitoring task includes collecting and analyzing river bed samples in the sand-bed reach  
7 of the San Joaquin River in order to improve understanding of the sediment transport  
8 behavior of the river.

9  
10 Channel bed samples from Reaches 1B, 2A, and 2B were collected at the topographic  
11 survey sites during the survey performed in February 2011, after the flood flow release of  
12 6,000cfs from Friant Dam during the first week of January and prior to 7,500cfs during  
13 the first week of April 2011. Bed samples were then analyzed in the DWR laboratory and  
14 the data is presented in this report.

## 15 **11.2 Methods**

### 16 **11.2.1 Sampling Locations**

17 The riverbed sampling sites were located between River Mile 212 and River Mile 235.  
18 The sampling locations were selected within the selected topographic monitoring sections  
19 (see Report: Topographic Surveys) designated as M1, M2, M3, M4, M5, M6, M6½, M7,  
20 M8, M9, M10, M11, M12, M13, and M14. The sampling locations are displayed in  
21 Figure 1. Samples that had significant sediment size variation within one section were  
22 designated M#-# (ex. M5-2).

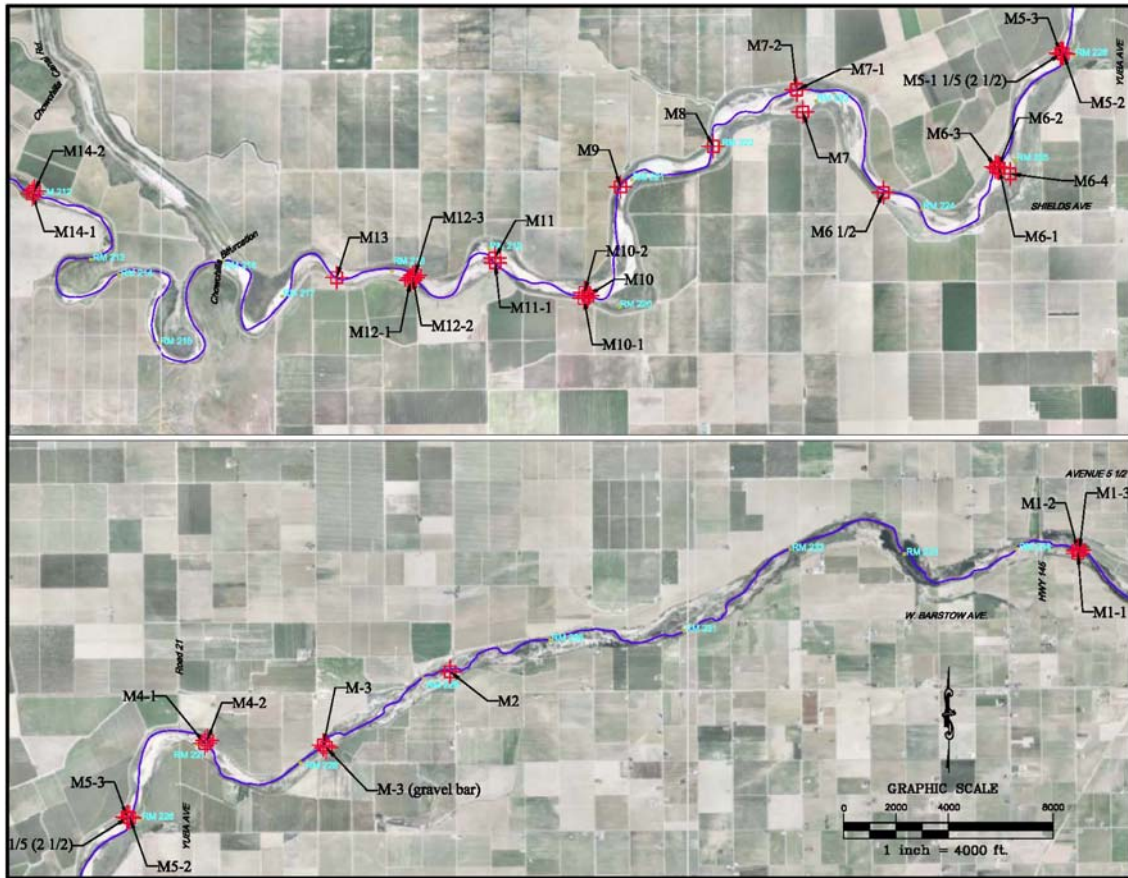

Figure 11-1. Sampling Location Map

### 11.2.2 Sample Collection

The bed samples were collected at a minimum of one location at each site during monitoring cross section surveys performed after each significant flow releases from Friant Dam. During each set of sample collection, the sampling locations were kept as close as possible to the initial locations using a handheld GPS.

The coordinates of the new sampling locations were recorded using a Total Station right before sampling. The bed samples were collected using a shovel and placed in either 1-gallon Ziploc bags for sandy material or a 5-gallon plastic bucket for coarser material. Only the top six inches of the surface was taken from each sample location. When the sizes were more variable, the sample locations were chosen to represent the variation. Multiple samples (four maximum) were obtained from each section. Analyses were performed as described in the 2009 ATR.

### 11.2.3 Sample Analysis and Calculation – $D_{84}$ and $D_{50}$

Analyses and necessary calculations were performed as described in 2009 and 2010 ATRs.

1 **11.3 Results**

2 Bed samples were collected three times in 2009 and 2010 to evaluate the changes in the  
3 substrate characteristics after each seasonal interim flow releases from Friant Dam. Those  
4 samples were analyzed and the data were presented in 2009 and 2010 ATRs.

5  
6 Another set of sample collection was performed in February 2011, after the 6,000cfs  
7 flood release from Friant Dam. The D84 and D50 values of these samples were computed  
8 and compared with the data from previous samplings. The summary of the comparison is  
9 tabulated in Table 1.

10

Table 11-1. Sample analyses results

Reach	RM	Cross Section	After Spring 2009 Flow		Before Spring 2010 Flow		After Spring 2010 Flow		After Winter 2010 High Flow (Jan 2011)	
			D84, mm	D50, mm	D84, mm	D50, mm	D84, mm	D50, mm	D84, mm	D50, mm
Reach 1B	234.4	M1-1					1.2	0.7	n/a	n/a
		M1-2					4.0	1.0	2.3	0.8
		M1-3					41.6	22.1	42.1*	18.8*
	229.2	M2					20.8	2.0	17.1	1.8
Reach 2A	228.1	M3 (gravel bar)	34.2	5.9	n/a	n/a	n/a	n/a	37.4	6.9
		M3	1.7	0.8	1.5	0.9	40.5	24.2	28.1	14.7
	227.0	M4-1	19.4	8.1	28.3	15.6	25.3	4.8	15.4	9.1
		M4-2	1.8	1.0	n/a	n/a	19.3	5.9	24.0	2.2
	226.0	M5-1.5	2.0	0.5	7.3	1.3	2.2	1.1	13.4	1.6
		M5-2	6.3	1.1	2.1	1.0	2.1	0.8	3.5	1.0
		M5-3	1.2	0.8	n/a	n/a	3.6	1.2	1.8	1.0
	224.9	M6-1	14.3	2.3	n/a	n/a	14.2	1.1	13.9	1.2
		M6-2	2.1	0.9	7.9	1.4	2.0	1.0	13.0	1.7
		M6-3	1.3	0.9	n/a	n/a	1.2	0.9	1.1	0.6
		M6-4			13.5	3.6	10.9	1.0	16.0	8.4
	223.8	M6½	10.8	0.6	1.9	0.9	13.7	1.2	1.4	0.8
	222.9	M7	1.2	0.5	n/a	n/a	1.1	0.7	0.9	0.5
		M7-1			2.1	1.1	1.9	0.9	2.5	1.1
		M7-2			1.4	0.9	1.5	0.8	2.1	1.0
	222.0	M8	1.3	0.7	1.2	0.7	1.8	0.9	1.0	0.5
	220.9	M9	1.1	0.7	1.2	0.7	1.9	0.9	2.0	0.9
	219.9	M10	1.2	0.8	1.1	0.8	1.7	1.0	1.0	0.6
		M10-1					1.7	1.0	1.2	0.9
		M10-2					2.6	0.9	1.2	0.8
	219.0	M11	1.2	0.6	1.4	0.8	1.0	0.5	0.7	0.4
		M11-1					1.3	0.8	1.1	0.6
	218.2	M12-1	3.1	0.9	n/a	n/a	2.9	1.3	0.6	0.4
M12-2		1.7	0.9	n/a	n/a	1.6	0.7	2.9	0.8	
M12-3						1.1	0.6	1.9	1.0	
217.5	M13	1.7	0.8	1.1	0.8	1.5	0.8	1.4	0.7	
Reach 2B	212.0	M14-1					1.7	0.6	3.2	0.9
		M14-2					2.1	0.7	1.1	0.6

3 Note: \* - Sampled at approximately 15 ft upstream of original location.

1

## 2 **11.4 Discussion**

### 3 **11.4.1 Reach 1B**

4 There was no significant change in particle size observed in M1 and M2 sites. M1-1  
5 sample was not collected and M1-3 sample was collected at approximately 15 ft upstream  
6 of the previous location due to high water level.

### 7 **11.4.2 Reach 2A**

8 Some significant changes in particle size were observed at a few sampling locations from  
9 Sites M3 through M6½, whereas the rest of the sites showed slight or no changes (see  
10 Table 1). M5-1.5, M6-2, and M6-4 showed a significant increase in particle size after the  
11 high flood flow release, whereas, M3, M4-1, and M6½ showed a decrease in particle size.  
12 Site M3 (gravel bar) was sampled after fall 2009, since it was inundated for the first time  
13 during our monitoring period. There was no significant change in particle size observed  
14 in M3 (gravel bar) during this high flow release.

### 15 **11.4.3 Reach 2B**

16 There was no significant change in particle size observed in M14, which is the only  
17 selected site in Reach 2B.

## 18 **11.5 Conclusions and Recommendations**

19 No significant changes in bed material size were observed before and after the scheduled  
20 flood flow release of 6,000cfs from Friant Dam except sites from M3 through M6½.

21

22 At most of the sampling locations at Sites M5 and M6, bed materials collected after the  
23 scheduled flood flow release of 6,000cfs are significantly coarser than the sample  
24 collected in October 2010 (after spring 2010 flow releases), whereas samples from Sites  
25 M4 and M6½ are finer than the October 2010 samples. The reason for these phenomena  
26 may be either due to coarse/fine material movement from upper reaches or loss of fine  
27 material during high flows.

28

29 Sample collection should be performed again after flood and spring flow releases from  
30 Friant Dam has subsided. Data should be analyzed to determine channel response at each  
31 location due to flow events and to try to identify trends. Depending on analysis results,  
32 future data collection may be triggered by higher flow events than the interim flow  
33 regime currently provides.

34

# 12.0 Additional Water Level Recorders

## 12.1 Introduction

The data reported in this section is related to the study “Additional Water Level Recorders” that specifically address needs related to Problem Statement 5 in the 2011 Agency Plan, San Joaquin River Channel Capacity Management, and indirectly address certain aspects of other problem statements by providing a continuous record of water surface elevations at key locations during interim flow releases to calibrate hydraulic models being used to assess channel capacity, fishery habitat, channel bed stability and many other aspects of Restoration Planning and Design.

Five additional water level recorders (Recorders 1 through 5) were installed at Reach 1A prior to the start of the 2009 Interim Flow releases and another one (Recorder 6) was installed at Reach 1B prior to the start of the 2010 Spring Interim Flow release. The stage data are continuously being collected from the dates of installations.

## 12.2 Methods

As shown in Figure 1, this particular type of Water Level Recorder (WLR), Global Water-WL16U, is an integrated unit consisting of a submersible pressure transducer (pressure sensor) connected to the data logger with a standard 25-foot cable (longer cable lengths are available). Refer to the 2009 ATR for more detailed information about installation methods.



Figure 12-1. Water Level Recorder

The data from the recorders were downloaded periodically and used to compute Water Surface Elevation (WSE). The necessary calculation methods were described in detail in the 2010 ATR.

## 12.3 Results

Coordinates of WLR locations and the recording dates for 2010/2011 are summarized in Table 1. The coordinates associated with each recorder refer to the position of the Reports Appendix

1 corresponding transducer located in the channel bed. Recorder 4 was replaced with a new  
 2 one on February 2011 and the new coordinates were updated in the table displayed below  
 3 (Table 1).  
 4

**Table 12-1. Location of Water Level Recorders**

<b>WLR No</b>	<b>Location</b>	<b>Reach</b>	<b>River Miles</b>	<b>Northing</b>	<b>Easting</b>	<b>Elevation</b>	<b>Date Recorded</b>
1	Head Ledger Island	1A	263.4	1806574	6783091	289.21	10/01/2010 - 5/31/2011
2	Willow Unit Grade Control		261.5	1800801	6781533	284.93	
3	Rank Island Grade Control		260.4	1796241	6780278	274.85	
4	Sycamore Island Flow Split		251.1	1769841	6755774	245.35	
5	Milburn Unit		248.4	1769997	6747942	232.90	
6	R 1B-1_RM 237.7	1B	237.7	1760168	6704615	206.91	

5  
 6 Water stage data that were stored in data loggers of all WLRs were downloaded  
 7 periodically using a field computer with Global Logger v2.0.6 software installed.  
 8 Collected stage data from October 2010 through May 2011 were converted as elevation  
 9 data as described in the 2010 ATR and are presented in this report. The data collected  
 10 prior to this period were reported in 2009 and 2010 ATRs.

11  
 12 The data from the additional WLRs located in Reach 1A are presented in Figure 2 and  
 13 Figure 3. In addition, the data from US Geological Survey (USGS) gauges located in the  
 14 same reach are extracted on-line from California Data Exchange Center (CDEC) website  
 15 and presented in Figure 4 for comparison purposes.  
 16



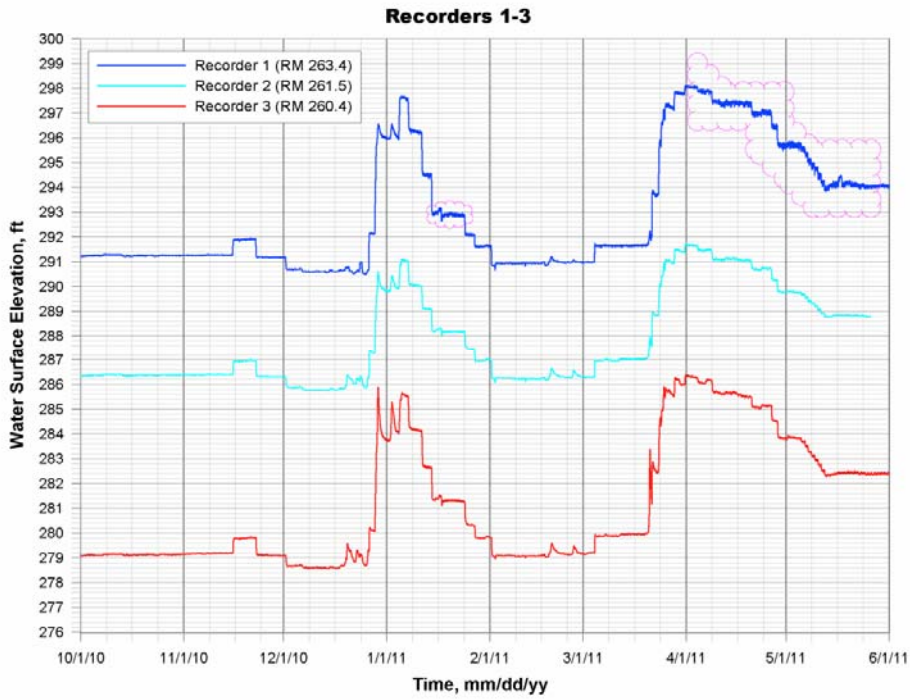

Figure 12-2. Water Level Recorders 1, 2, & 3 Elevation Data

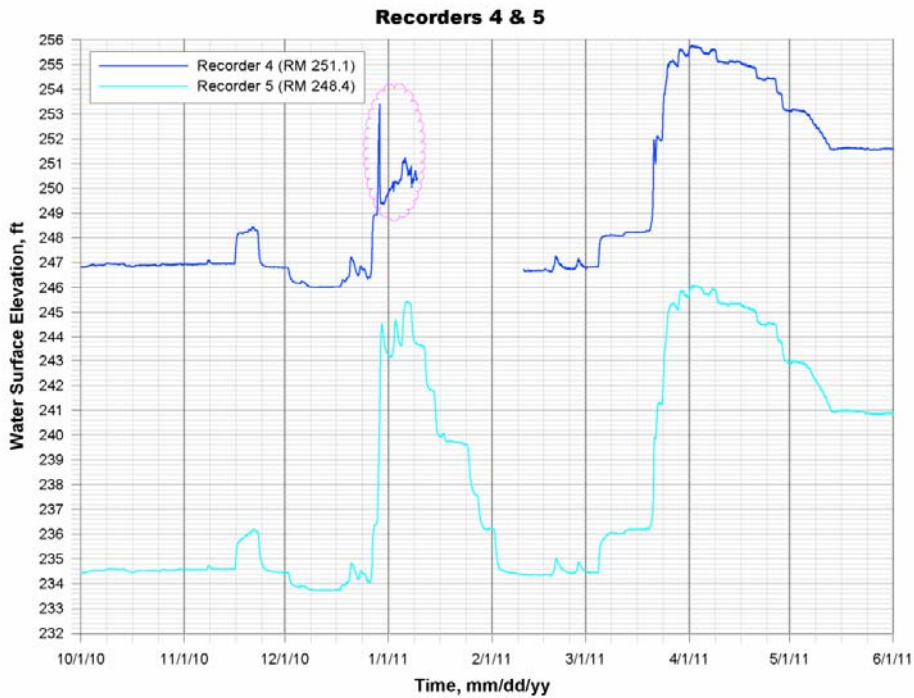
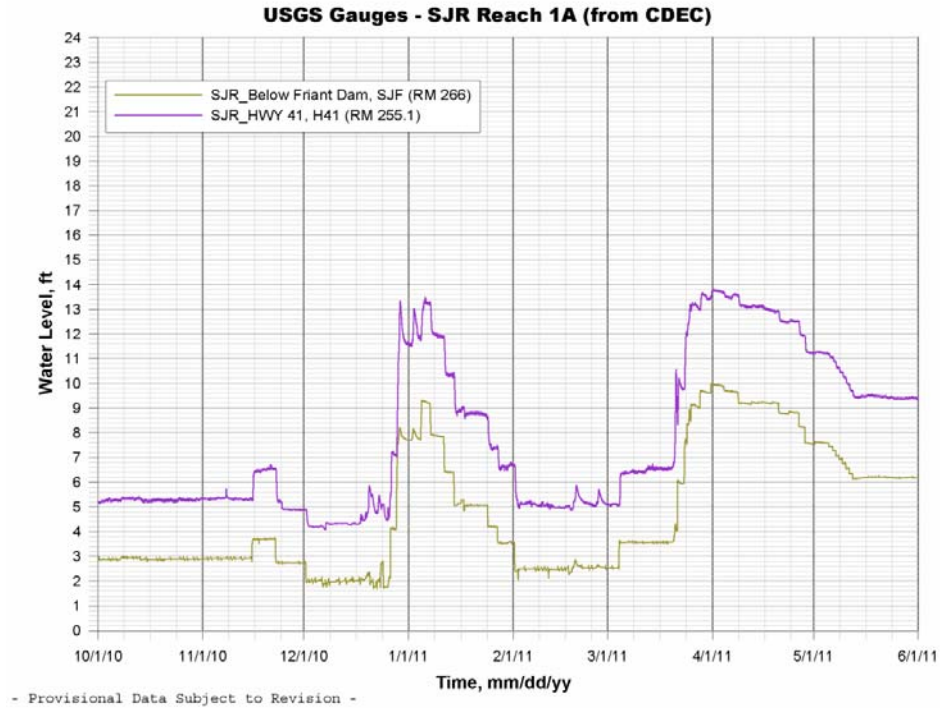

Figure 12-3. Water Level Recorders 4 & 5 Elevation Data



1  
2  
3  
4  
5  
6

Figure 12-4. USGS Gauge at Reach 1A Elevation Data

Similarly, the data from WLR 6 located in Reach 1B and the USGS gauge located in the same reach at Donny Bridge is presented in Figure 5 and Figure 6.

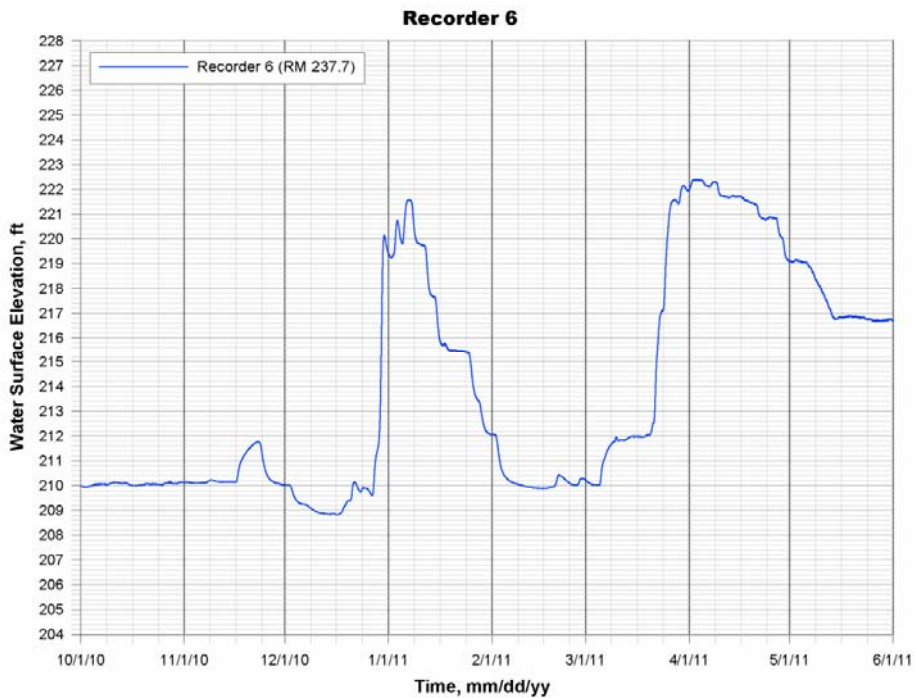

7  
8

Figure 12-5. Water Level Recorder 6 Elevation Data

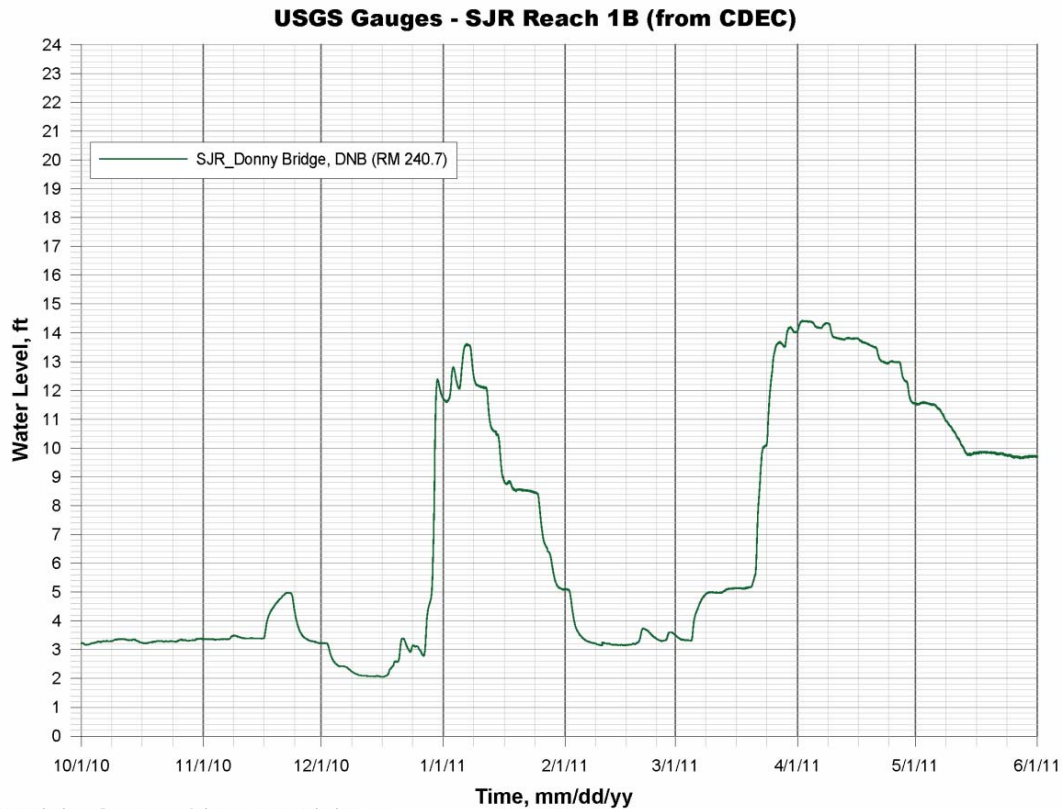

1  
2

**Figure 12-6. USGS Gauge at Reach 1B Elevation Data**

### 3 **12.4 Discussion**

4 According to Figure 2, Recorder 1 indicates water level fluctuations during the third  
 5 week of January 2011 as well as in April and May (see pink markups). However,  
 6 Recorder 2 and 3 located downstream of Recorder 1 did not show any significant  
 7 fluctuation in the data during the same period. As a result, the accuracy of the data for  
 8 Recorder 1 during this period of time is suspect. A similar type fluctuation in the data  
 9 from the same recorder was observed in 2009 and our field investigation at that time  
 10 identified that accumulated vegetation and debris loosened one of the anchors and made  
 11 the end of the pipe, which accommodates the transducer, move vertically about 2-3  
 12 inches due to water force. A similar issue might have occurred again due to high flood  
 13 flow releases from Friant Dam. A field inspection will be performed to rectify this issue  
 14 during this summer as soon as the water level comes to a safe working condition.

15  
 16 In addition, a sudden fluctuation in water levels within a day was observed from  
 17 Recorders 1 through 5 in between March 20 and March 22, 2011. The amplitude of this  
 18 fluctuation increased from Recorder 1 through 3, peaked at approximately 2 ft at  
 19 Recorder 3, and then receded at Recorder 5 (see Figure 2 and Figure 3). This sudden  
 20 fluctuation was also observed in the USGS gauges located in Reach 1A (see Figure 4).  
 21 The gauge at HWY 41 showed approximately the same amplitude as Recorder 3, which

1 is located about 5 miles upstream of HWY 41. The storm event that occurred right before  
2 and during this period is the likely explanation for the above phenomena. According to  
3 National Oceanic and Atmospheric Administration website (www.noaa.gov), total  
4 precipitation in Friant and Fresno area for the 48 hours period ending at 4:00 pm PDT  
5 March 21, 2011 was ranging from 2.1 – 2.6 inches and there were also some relatively  
6 smaller amount of precipitation (~ 0.2 inches) accounted on the day before the above  
7 period.  
8

9 The data logger of Recorder 4 was over-topped during the high flood flow releases that  
10 occurred at the end of last year. It started collecting unusual data from December 29,  
11 2010 and stopped functioning on January 9, 2011 (see pink markup in Figure 3). A  
12 sudden drop in the data of Recorder 4 can be observed in Figure 4, when the WSE  
13 reached the approximate elevation of the data logger (253.3 ft). This recorder was  
14 replaced with a new one and was back on-line February 10, 2011 after water levels in the  
15 river came to a safe working condition.  
16

17 The data from Recorder 6 matches with that of the USGS gauge at Donny Bridge, which  
18 is about 3 miles upstream (see Figure 5 and Figure 6).

## 19 **12.5 Conclusions and Recommendations**

20 Data from the transducers will be compared to model results, and adjustments will be  
21 made to the models, as necessary, to better match the data. This data will also be cross  
22 checked with WSE data measured during water surface profile survey for quality control.  
23

24 The existing recorders should continuously be monitored and the data collection should  
25 be done periodically. Necessary action should be taken to investigate and rectify the  
26 fluctuation of readings in Recorder 1, after the water level in the river returns to safe  
27 conditions. All WLRs will be resurveyed to make sure that no movement occurred during  
28 high flood flow releases.  
29

30 It is recommended to evaluate the possibility of moving a recorder from Reach 1A or to  
31 install a few additional recorders in Reach 2 to provide wider spatial distribution of  
32 calibration data. We are currently reviewing possible options for relocation.  
33

# 1 **13.0 Report: Water Surface Profile**

## 2 **13.1 Introduction**

3 The data in this report was collected as part of the Channel Capacity Management study,  
4 Surface Water Profile Surveys and Discharge Measurements study (2011 Agency Plan  
5 Section 10).

6  
7 Inundation levels, channel capacity and channel response to restoration releases requires  
8 knowledge of the water surface elevations and hydraulic conditions along the reach.  
9 Specific measurements of the water surface elevations at about 0.5-mile intervals, with  
10 more frequency at water surface slope changes, that can be correlated with concurrent  
11 discharge measurements at known, steady-state discharges provide a means of assessing  
12 water surface elevations and associated hydraulic conditions, and the extent of inundation  
13 along the reach. These data provide a direct means of calibrating the hydraulic models to  
14 specific ranges of discharge.

## 15 **13.2 Methods**

### 16 *Procedure*

17 Water surface profiles were obtained using a survey grade GPS (3D quality of 0.1 foot) to  
18 record the water surface elevations along the river. The horizontal datum used was the  
19 California Coordinate System Zone 3, US Survey Feet, based on the California Geodetic  
20 Coordinates of 1983, Epoch 2007.0. The vertical datum used was the North American  
21 Vertical Datum of 1988. Orthometric heights were derived from RTK observations and  
22 application of GEOID03 to the RTK values. RTK observations were received from the  
23 Leika network solution via a cell phone modem attached to the GPS receiver. Existing  
24 control points were used to validate the accuracy of the data.

25

### 26 *Timing*

27 Below is a table showing when each reach was surveyed.

28

Table 13-1. Timing for water surface elevation survey

Reach	Start Location	End Location	Date	# of WSP collected
1A	Road 206	Hwy 41	2011-01-05	111
1A	Hwy 41	Hwy 99	2011-01-06	107
1B	Hwy 99	Gravelly Ford	2011-01-07	100
2A	Gravelly Ford	Chowchilla Bifurcation Structure	2011-01-08	68
Chowchilla Bypass	Chowchilla Bifurcation Structure	Avenue 14 Bridge	2011-01-09	48
3	Mendota Dam	Firebaugh Park	2011-01-10	31
3	Firebaugh Park	Sack Dam	2011-01-11	53
1A	Road 206	Hwy 41	2011-03-29	124
1A	Hwy 41	Hwy 99	2011-03-30	97
1B	Hwy 99	Gravelly Ford	2011-03-31	97
2A	Gravelly Ford	Chowchilla Bifurcation Structure	2011-04-01	55
3	Mendota Dam	Firebaugh Park	2011-04-04	41
3	Firebaugh Park	Sack Dam	2011-04-05	52
Chowchilla Bypass	Avenue 14	Road 9	2011-04-06	21
Eastside Bypass	Road 9	Road 4	2011-04-06	45
Eastside Bypass	Road 4	Washington Rd.	2011-04-07	39
4A	Sack Dam	Washington Rd.	2011-04-12	61
1A	Road 206	D7/Riffle 38	2011-05-02	45
1A	D7/Riffle 38	Hwy 41	2011-05-03	55
1A	Hwy 41	Hwy 99	2011-05-04	87
1B	Hwy 99	Gravelly Ford	2011-05-05	105
2A	Gravelly Ford	Chowchilla Bifurcation Structure	2011-05-06	65

2

3

4 *Locations*

5 Survey locations were placed at the top and bottom of hydraulic controls, at the top and  
6 bottom end of long pools, and about 500 feet upstream, at, and 500 feet downstream of  
7 discharge measurement cross-sections. An attempt was made to limit the drop between  
8 points to no more than half a foot.

Reports

Appendix

1 **13.3 Results**

2 Data tables containing all of the survey point locations and elevations are available in  
3 electronic format and are distributed on an as-requested basis.

4  
5 The number of data points collected for each reach is reported above in Table 1.

6 **13.4 Discussion**

7 As established prior to the monitoring effort, the spacing of surveyed water surface points  
8 varied, as necessary, according to channel slope and local conditions. Longitudinal  
9 distances between survey points were often reduced significantly as specific locations in  
10 order to refine abrupt changes in the water surface profile by collecting data at the top  
11 and bottom of riffles and other hydraulic controls. Larger distances between points were  
12 used in the large pools and backwater areas without impacting the accuracy of the water  
13 surface profile.

14  
15 A preliminary comparison of the surveyed and computed water surface profiles based on  
16 the current 1-D HEC-RAS model indicates that the majority of significant hydraulic  
17 controls were sufficiently characterized by the survey data, and that no noticeable gaps in  
18 the data exist. Brief comparisons of the survey data and current model results also  
19 indicate that additional model calibration is necessary and can now be performed in  
20 numerous locations where previous calibration data didn't exist.

21  
22 The preliminary review of the data also indicates that, in general, no significant  
23 anomalies exist. However, an occasional subtle rise in water surface elevation in the  
24 downstream direction does exist, but the average magnitude of these instances is only  
25 approximately 0.1 feet and can be explained by a combination of error tolerance in the  
26 equipment and error in the exact placement of the survey rod. In some cases, it could  
27 also possibly be a hydraulic jump occurring after a steep riffle or weir.

28  
29 For the April 1<sup>st</sup> survey of Reach 2A, GPS error correction network coverage was poor  
30 from river mile 226.0 to river mile 223.6, so no water surface elevation data was  
31 recorded. For the May 6<sup>th</sup> survey, a base station with radio transmitter was setup at  
32 Gravelly Ford. When the survey crew reached river mile 226.0, the rover was switched  
33 to a radio modem until river mile 223.6. At river mile 223.6, it was switched back to a  
34 cell modem.

35 **13.5 Conclusions and Recommendations**

36 *Conclusions*

37 Comparisons between predicted water surface elevations in the 1D model and measured  
38 water surface elevations have improved the model's performance, and will provide more

1 certainty in predicted inundation levels, channel capacities and other channel responses to  
2 the restoration releases.

3  
4 *Recommendations*

5 Trigger flows to conduct measurements that would aide modeling most are flows confined by  
6 the following indications:

- 7 1) lowest commonly expected flow,
- 8 2) flows wetting the bottom of the low flow channel,
- 9 3) flows near the bank full flow that govern channel shape,
- 10 4) flows that just wet the overbank floodplain areas, and
- 11 5) flood flows that produce significant overbank flow.

12 Most of these trigger flows have been monitored for each reach. During the month of June,  
13 2011, monitoring was done on Reach 1A, 1B, and 2A at a flow of about 2,500cfs. The data  
14 collected from the June run is not reported in this ATR release, but will be reported in the  
15 next ATR. The flows and associated reaches that have yet to be surveyed are listed below in  
16 Table 2.

17  
18 **Table 13-2. Future monitoring trigger flows**

Reach	Trigger CFS		
	1	2	5
1B	350	700	
2B		700	
3	350		4,500
Chowchilla		700	



# 1 14.0 Discharge Measurements

## 2 14.1 Introduction

3 The data in this report was collected as part of the Channel Capacity Management study,  
4 Surface Water Profile Surveys and Discharge Measurements study (2011 Agency Plan  
5 Section 10), which is based on the measurement plan from Mussetter Engineering (2008).  
6 Discharge data is collected to evaluate discharge at specific split flow locations and at a  
7 five mile maximum increment along the river to correlate with the continuous record of  
8 water surface elevations. The discharge measurements are being used to calibrate and  
9 validate hydraulic models that are used to assess channel capacity, channel stability,  
10 fishery habitat, and other aspects of restoration planning and design.

## 11 14.2 Methods

### 12 1. Discharge Measurements. 6,000, 7,500, and 4,500 cfs Scheduled Release.

13 b. An Acoustic Doppler Current Profiler (ADCP) was towed behind an inflatable  
14 kayak or in front of a raft, to measure velocities and flow area along a path  
15 between banks to determine the discharge at a site. The sites were located at  
16 existing sites from D4 (Discharge 4) in reach 1A-1 through D32 in reach 3. Maps  
17 locating these sites can be found in the 2010 Annual Technical Report. Sites were  
18 added for Chowchilla Bypass and Eastside Bypass channels. The Bypass sites  
19 will be reported on more fully in the 2011 Final Annual Technical Report  
20 document. Specific dates for measurements by reach are indicated in Table along  
21 with the scheduled release discharge for Friant reported on CDEC for station  
22 MIL.

Reach	Date	Scheduled Release (cfs)
1A-1	1/5/11	6,000
1A-2	1/6/11	6,000
1B	1/7/11	6,000/5,500/5,000/4,500
2A	1/8/11	4,500
3-1	1/10/11	4,500
3-2	1/11/11	4,500/4,000/3,500/3,000

Chowchilla Bypass	1/9/11	4500
1A-1	3/28/11	6,000/6,500/7,000
1A-1	3/29/11	7,000
1A-2	3/29/11	7,000
1A-2	3/30/11	7,000
1B	3/31/11	7,000/7,500
2A	4/1/11	7,500
3-1	4/4/11	7,500/7,250
3-2	4/5/11	7,250
Chowchilla Bypass	4/6/11	7,250
East Side Bypass	4/7/11	7,250
1A-1	5/2/11	4,500
1A-1	5/3/11	4,500
1A-2	5/4/11	4,500
1B	5/5/11	4,500/4,300
2A	5/6/11	4,300/4,100

1 Table 14-1 Discharge Measurement Date by Reach and Friant Scheduled Release in cubic feet per second  
2 reported from CDEC

3

#### 4 **14.3 Results**

5 Three measurement sets performed during spring are being reported on. The sequence  
6 and quantity of sites measured was modified due to the flows encountered during  
7 measurements. Summaries of the results in Data Appendix G are tabulated here:

1

• Table 14-2 Measured Discharge during Jan 2011, 6,000 cfs Friant Scheduled Release

Reach	Site	Location (RM)	Date/Time	Flow Measured (cfs)
Reach 1A	Discharge 4	263.6	1/5/2011 10:00 - 10:35	5,866
	Discharge 4s	263.6	1/5/2011 11:00 - 11:30	561
	Discharge 6	261.5	1/5/2011 15:30 - 16:00	6,130
	Discharge 7	260.8	Inaccessible	N/A
	Discharge 8	260.5	1/5/2011 15:30 - 16:00	6,510
	Discharge 8s	260.4	No Split - Fully Inundated	N/A
	Discharge 11	255.3	1/6/2011 9:15 - 10:00	6,290
	Discharge 12	251.9	1/6/2011 11:15 - 11:35	6,350
	Discharge 12s	251.0	No Split - Fully Inundated	N/A
	Discharge 16	248.8	1/6/2011 13:20 - 13:50	6,380
Discharge 17	243.5	1/6/2011 14:20 - 15:10	6,430	
Reach 1B	Discharge 18	237.7	1/7/2011 11:00 - 11:30	6,160
	Discharge 19	232.5	1/7/2011 15:00 - 15:20	5,980
Reach 2A	Discharge 22	221.8	1/8/2011 12:10 - 12:45	5,730
	Discharge 23	218.5	1/8/2011 15:00 - 15:40	5,760
Reach 3	Discharge 28	202.9	1/10/2011 10:45 - 11:00	1,790
	Discharge 29	197.7	1/10/2011 12:30 - 12:50	1,790
	Discharge 30	193.6	1/11/2011 10:30 - 10:50	1,770
	Discharge 31	189.8	1/11/2011 12:45 - 13:00	1,750
	Discharge 32	184.5	1/11/2011 14:20 - 14:40	1,740
Chow-chilla Bypass	Discharge 51		1/9/2011 11:10 - 11:45	3,820
	Discharge 52		1/9/2011 15:10 - 15:50	4,120

2

3

• Table 14-3 Flow Measurement Data During March 2011, 7,000 cfs Friant Scheduled Release

Reach	Site	Location (RM)	Date/Time	Flow Measured (cfs)
Reach 1A	Discharge 4	263.6	3/29/2011 9:52 - 10:18	6,334
	Discharge 4s	263.6	3/29/2011 11:18 - 11:46	571
	Discharge 6	261.5	3/29/2011 13:56 - 14:15	6,939
	Discharge 6s	261.5	3/29/2011 14:49 - 15:13	320

Reach	Site	Location (RM)	Date/Time	Flow Measured (cfs)
	Discharge 6r	261.5	3/29/2011 10:41 - 11:03	220
	Discharge 7	260.8	3/29/2011 12:15 - 12:31	6,378
	Discharge 8	260.5	3/29/2011 14:10 - 14:27	7,370
	Discharge 8s	260.4	No Split - Fully Inundated	
	Discharge 11	255.3	3/29/2011 16:29 - 17:02	7,396
	Discharge 11	255.3	3/30/2011 7:17 - 7:42	6,849
	Discharge 12	251.9	3/30/2011 10:04 - 10:28	6,575
	Discharge 12s	251.0	No Split - Fully Inundated	
	Discharge 12c	252.9	3/30/2011 11:04 - 11:10	409
	Discharge 16	248.8	3/30/2011 11:52 - 12:00	6,765
	Discharge 17	243.5	3/30/2011 12:37 - 13:21	6,949
Reach 1B	Discharge 18	237.7	3/31/2011 10:27 - 11:17	7,094
	Discharge 19	232.5	3/31/2011 13:40 - 13:55	7,122
Reach 2A	Discharge 22	221.8	4/1/2011 11:21 - 11:43	7,031
	Discharge 23	218.5	4/1/2011 13:38 - 14:16	7,294
Chowchilla Bypass	Discharge 52		4/6/2011 8:41 - 9:57	5,798
	Discharge 53		4/6/2011 11:59 - 12:33	7,156
Eastside Bypass	Discharge 55		4/6/2011 15:55 - 16:17	7,471
	Discharge 55		4/7/2011 8:44 - 9:43	7,207
	Discharge 56		4/7/2011 12:15 - 12:28	6,745

1

2

• [Table 14-4 Flow Measurement Data During May 2011, 4,500 cfs Friant Scheduled Release](#)

Reach	Site	Location (RM)	Date/Time	Flow Measured (cfs)
Reach 1A	Discharge 4	263.6	5/2/2011 10:22 - 10:39	4,518
	Discharge 4s	263.6	5/2/2011 9:07 - 9:37	86
	Discharge 6	261.5	5/2/2011 13:54 - 14:26	4,484
	Discharge 7	260.8	5/2/2011 15:52 - 16:25	4,180
	Discharge 8	260.5	5/3/2011 9:27 - 9:54	4,418
	Discharge 8s		No Split - Fully Inundated	

Reach	Site	Location (RM)	Date/Time	Flow Measured (cfs)
	Discharge 11	255.1	5/3/2011 12:44 - 13:27	4,460
	Discharge 12	251.2	5/4/2011 8:45 - 8:59	4,470
	Discharge12s		No Split - Fully Inundated	
	Discharge12c		5/4/2011 10:00 - 10:08	95
	Discharge 16	248.3	5/4/2011 11:39 - 12:18	4,078
	Discharge 17	245.2	5/4/2011 14:19 - 14:34	4,693
Reach 1B	Discharge 18	237.7	5/5/2011 9:18 - 10:03	3,946
	Discharge 19	232.5	5/5/2011 13:26 - 14:35	4,105
Reach 2A	Discharge 22	222	5/6/2011 9:34 - 10:17	4,134
	Discharge 23	218.3	5/6/2011 12:09 - 13:10	4,169

1

## 2 14.4 Discussion

3 January discharge measurements at the scheduled release of 6,000 cfs were performed  
4 due to the uncertainty of a larger flow occurring within this study's duration. If the  
5 desired 8,000 cfs release could not be obtained, the 6,000 cfs release would make an  
6 acceptable calibration point. The 6,000 cfs point generally overtopped the low flow  
7 banks, inundated the floodplains but did not wet the bottom of the flood levees. At this  
8 flow, connectivity with many of the high flow side channels and gravel pits was  
9 established. Some measurements of the 6,000 cfs Friant Scheduled Release are missing  
10 data from the lower portion of active flow in the transect. The measurement software  
11 automatically made assumptions for the velocities in the missing area in determining a  
12 discharge at the site. Precursory examination of the discharge measurements based on  
13 the transects' missing data appear consistent with other discharge measurements

14 In March, a scheduled release was seen at 7,500 cfs providing a much better fit for the  
15 8,000 cfs calibration flow. At 7,500 cfs the floodplain was fully inundated for most of  
16 the reaches and the bottom of the flood levees were wetted.

17 In May, scheduled releases from Friant included a 4,500 cfs bench to fill in the targeted  
18 4,000 cfs desired flow for calibration. 4,500 cfs flows overtopped the low flow banks  
19 and wetted most of the flood plain. 4,500 cfs flows also continued to wet most of the  
20 high flow side channels and pits that were inundated at higher flows.

1 **14.5 Conclusions and Recommendations**

- 2 • Additional location data analysis needs to be performed to indicate the specific  
3 locations at which the measurements were taken and how some of the  
4 measurements relate to surrounding split flow conditions. The split flow  
5 conditions may best be analyzed in the models.
- 6 • Analyses of reaches and discharge collections need to be performed to determine  
7 which reaches require additional measurements and the flow events that  
8 measurements are required at.
- 9 • The applicability of measurements that have transects that contain missing bottom  
10 velocities needs to be determined through further analysis of the measurements  
11 and consideration of how they are applied in the models.

12 **14.6 References**

- 13 2011 SJRRP Agency Plan 27-28 <http://restoresjr.net/flows/atr.html>  
14
- 15 Mussetter Engineering, Incorporated, (2008). DRAFT San Joaquin River Data Collection  
16 and Monitoring Plan, prepared for California Department of Water Resources, August  
17 27, 2008.  
18  
19

# 1 15.0 Topographic Surveys

## 2 15.1 Introduction

3 Data collections discussed in this report are performed as a part of the Channel Capacity  
4 Management study, Monitoring Cross Sections Re-surveys (2011 Agency Plan Section  
5 11) which expands on the monitoring plan from Mussetter Engineering (2008) by  
6 establishing topographic patches to better describe the channel and increase the contrast  
7 between surveys. Topographic surveys make a record of the existing channel bed, bank  
8 and feature elevations after potential bed forming flows have had a potential to disturb  
9 the previous elevations.

## 10 15.2 Methods

- 11 1. **Topographic Surveys.** Topographic surveys used a total station to complete a 3D  
12 survey of existing elevations of the channel. The survey method used multiple  
13 transects perpendicular to the channel extending between the left and right levee tops.  
14 Transects were spaced longitudinally along the channel at approximately 15 ft  
15 increments to encompass an area covering approximately 60 ft of channel length.  
16 This was performed in February 2011, after the Friant Scheduled Release of 6,000 cfs  
17 and before the Friant Scheduled Release of 7,500 cfs.

## 18 15.3 Results

19 Processing and analysis of data is currently incomplete. Results from this survey are  
20 planned to be reported on in the 2011 Final Annual Technical Report document.

## 21 15.4 Discussion

22 The results are expected to refine the estimated trigger conditions that determine the need  
23 for return surveys and are planned to be added to the 2011 Final Annual Technical  
24 Report.

## 25 15.5 Conclusions and Recommendations

- 26 • Current survey data collected for this study require additional analysis for  
27 presentation and should be incorporated into the 2011 Final Annual Technical  
28 Report document.

- 1 • Return surveys after the Friant Scheduled Release of 7,500 cfs should be planned  
2 for after discharge is returned to near baseline level.
- 3 • Analysis of the post- 7,500 cfs release survey should be performed and added to  
4 the 2011 Final Annual Technical Report document.
- 5 • Analysis contrasting all surveys for this study should be performed with a  
6 component relating the discharge volume and intensity required to cause  
7 significant alteration of the channel. This analysis should be used to aide in  
8 determining the trigger levels to re-survey for this study.

## 9 **15.6 References**

- 10 2011 SJRRP Agency Plan <http://restoresjr.net/flows/atr.html>  
11  
12 Mussetter Engineering, Incorporated, (2008). DRAFT San Joaquin River Data Collection  
13 and Monitoring Plan, prepared for California Department of Water Resources, August  
14 27, 2008.  
15



# 1 16.0 Adult Passage Study

## 2 16.1 Introduction

3 This document describes the Task 1 and Task 2 data collection and evaluation of  
4 potential fish passage barriers on the main stem of the San Joaquin River and bypass  
5 system, from Friant Dam to the Merced River confluence. The Department of Water  
6 Resources is performing this work as part of a Fish Passage Evaluation Plan that will be  
7 implemented for the San Joaquin River Restoration Program to identify and prioritize fish  
8 passage barriers in the Restoration Area in an effort to minimize migration delays,  
9 stranding, and mortality of juvenile and adult salmon and other native fish. The fish  
10 passage evaluation plan (2009) follows a phased approach separated in three main tasks.  
11 Task 1, deemed first pass, of the SJRRP fish passage evaluation has been completed  
12 (**Fish Passage Evaluation Draft TM** included in this ATR Reports Appendix) and  
13 identifies the potential passage impediments to migration of juvenile and adult salmon  
14 and other native fish. Task 2, deemed second pass, which is currently underway, includes  
15 data collection and hydraulic evaluation of the potential fish passage barriers that were  
16 identified for further study in Task 1. Task 3 may be completed after Task 2 to  
17 recommend improvement or repair to structures that were identified as barriers. -In this  
18 study, a fish passage barrier will include any natural channel restrictions and human-made  
19 crossings and structures over or through the SJR or bypasses designed to pass stream flow  
20 that will create a total, partial, or temporary barrier.  
21  
22

23 The following study is discussed in this report:

### 24 San Joaquin River Restoration Program Fish Passage Evaluation

- 25 • Task 1, Identification, Data Collection, and Initial Evaluation of Potential Fish
- 26 • Task 2, Data Collection and Hydraulic Modeling of Potential Fish Passage
- 27 • Task 3, Identification, Data Collection, and Initial Evaluation of Potential Fish
- 28 • Task 4, Data Collection and Hydraulic Modeling of Potential Fish Passage
- 29 • Task 5, Identification, Data Collection, and Initial Evaluation of Potential Fish
- 30 • Task 6, Data Collection and Hydraulic Modeling of Potential Fish Passage
- 31 • Task 7, Identification, Data Collection, and Initial Evaluation of Potential Fish
- 32 • Task 8, Data Collection and Hydraulic Modeling of Potential Fish Passage
- 33 • Task 9, Identification, Data Collection, and Initial Evaluation of Potential Fish
- 34 • Task 10, Data Collection and Hydraulic Modeling of Potential Fish Passage

35 This report will cover the methods in Task 1 that support the current work for Task 2 and  
36 will detail the current methods for Task 2 data collection and modeling. In addition, it  
37 will discuss the finding from the Task 1 document results and the limitations of this data.

1 **16.2 Methods**

2 **16.2.1 Task 1**

3 In this initial task, work included the identification and data collection of potential fish  
4 passage barriers, identification of the passage criteria to allow an initial evaluation of  
5 potential barriers, and identification of potential barriers for further study. During Task  
6 1, first pass surveys were completed to characterize the structure into three categories: not  
7 a barrier (Green), a definite barrier (Red), or need more information on whether it is a  
8 barrier or not (Gray). The result of the initial evaluation of each structure categorizes  
9 each structure as Green/Gray/Red as it relates to fish passage. The Task 1 background  
10 and methods were reported in the November 2010 ATR in Appendix A, Section 25  
11 (SJRRP, 2010b).

12 **16.2.2 Task 2**

13 The following methods detail Task 2 of the SJRRP fish passage evaluation that includes  
14 data collection and hydraulic evaluation at potential fish passage barriers that were  
15 identified for further study in Task 1.

16 A thorough hydraulic evaluation will be completed for each potential barrier to compare  
17 with the most current fish passage criteria that has been developed for the SJRRP project  
18 area combined with the regulatory criteria developed by the National Marine Fisheries  
19 Service (NMFS, 2001) (NMFS, 2008) and California Department of Fish and Game  
20 (CDFG, 1998) (CDFG, 2002). The only exception would be the Beaver Dams since  
21 these are natural structures and may or may not be present after the latest flood event or  
22 may no longer fit the definition of a potential barrier

- 23 1. **Calibration Data Collection.** Current efforts have focused on collection of  
24 hydraulic data at each structure identified in Task 1 for further study. Structures  
25 listed as Gray for further study in Task 1, shown in Table 1 and Figure 1, were  
26 identified as potential partial barriers. Two additional barriers, which were  
27 identified as Red, were added to the list for further study. Hydraulic data is  
28 needed to evaluate passage conditions at the structures under a variety of flow  
29 conditions; such as flow depth, velocity, and discharge. This data will allow for  
30 the hydraulics at the site to be estimated and compared with the fish capabilities to  
31 determine the fish passage success.

32 **Table 16-1.** Task 2 Second Pass Locations

Identification Number	Description	Reach
4	Lost Lake Rock Weir #1	Reach 1A
5	Lost Lake Rock Weir #2	Reach 1A
17	Donny Bridge	Reach 1B
23	San Mateo Avenue	Reach 2B
29	Sand Slough Connector	Reach 4A
36	Beaver Dam #5	Reach 4B

37	Beaver Dam #4	Reach 4B
38	Refuge Low Flow Crossing	Reach 4B
39	Beaver Dam #3	Reach 4B
40	Beaver Dam #2	Reach 4B
41	Beaver Dam #1	Reach 4B
48	Eastside Bypass Bifurcation	Eastside Bypass
49	Mariposa Bypass Bifurcation	Mariposa Bypass
51	Dan McNamara Road	Eastside Bypass
69	Rock Weir	Eastside Bypass

1

2 **Figure 16-1.** Task 2 Second Pass Locations

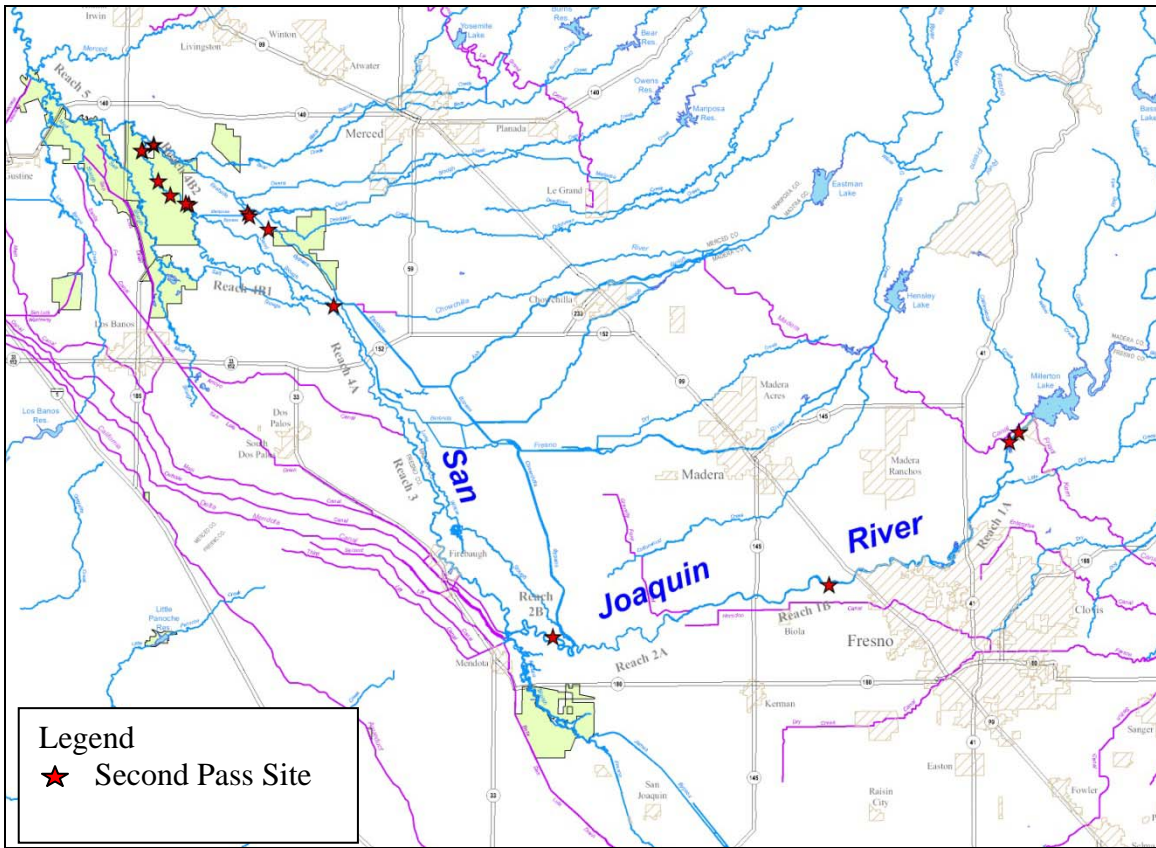

3

4

5 c. Flow ranges for calibration data collection depends on the reach and is subject to  
 6 change based on staff and equipment availability, Friant Dam scheduled and/or  
 7 anticipated releases, and access.

8 Maximum flow range – 4,000 – 2,500 cubic-feet-per-second (cfs)

9 Intermediate flow range – 1,500 – 1,000 cfs

1 Minimum flow range – 350 – 30 cfs

2 d. Methods used by DWR to collect water-surface profile surveys and measuring  
3 discharge are presented in the 2010 ATR.

4 2. **Hydraulic Modeling.** Current efforts have focused on developing the procedures to  
5 model each structure to compare with the fish passage criteria. The results can be  
6 used to determine the percent passage for migrating adults Chinook salmon and  
7 juveniles and other fish species and lifestages.

8 a. Hydraulic modeling will be based on the one-dimensional HEC-RAS (USACE,  
9 2005) models developed by Tetra Tech and have varying topographic,  
10 bathymetry, and calibration data.

11 b. A preliminary hydraulic analysis will be completed using the existing HEC-RAS  
12 models to identify additional data that may be necessary to complete a thorough  
13 analysis of the potential barrier at a range of flows. This includes the collection of  
14 additional water surface elevations and flow for model calibration, topography,  
15 bathymetry and structure details. Every effort will be made to collect the  
16 information that is identified during Task 2.

17 c. The models will then be refined to the fullest extent possible. In addition, any  
18 new data that has been collected to date will supersede any existing data within  
19 the models.

## 20 **16.3 Results**

### 21 **16.3.1 Task 1**

22 Task 1 of the SJRRP fish passage evaluation has been completed (**Fish Passage**  
23 **Evaluation Draft TM** included in this ATR Reports Appendix) to identify potential  
24 passage impediments to migration of juvenile and adult salmon and other native fish.  
25 Task 1 results categorize each structure as Green/Gray/Red as it relates to fish passage.  
26

- 27 • Green – The location is assumed adequate for passage of all salmonid species  
28 throughout all salmonid life stages and stream flows.
- 29 • Gray – The location may not be adequate for all salmonid species at all their life  
30 stages. More information is needed to evaluate the structure.
- 31 • Red – The location will likely fail to meet DFG and NMFS passage criteria at all  
32 flows for strongest swimming species presumed present.  
33

34 The First Pass surveys were completed during the months of July and August 2010 with  
35 flow releases from Friant Dam to the San Joaquin River that averaged 331 cfs and ranged  
36 from 295 - 361 cfs. The First Pass surveys were performed on 45 of the 68 structures  
37 identified as potential barriers in the San Joaquin River and flood bypasses. An additional  
38 structure was added to the evaluation after seeing it in the field and several more  
39 structures were evaluated based on existing data gathered in the field or from a distance.

Reports  
Appendix

1 The structures that were not surveyed could not be accessed due to lack of entry permits,  
2 locked gates, steep terrain, or water depth. Structures along the Chowchilla Bypass and  
3 lower Eastside Bypass were not surveyed because of current plans that do not include  
4 them in the project area; these have the potential to be surveyed in the future or if current  
5 plans change.

6  
7 A total of 49 potential barriers were evaluated during the first pass of those 28 structures  
8 were identified as green, 13 ranked as gray (Table 1), and 8 structures were identified as  
9 red and may be revisited for a second pass evaluation if survey data is needed to complete  
10 alternative designs for unimpaired passage.

### 11 **16.3.2 Task 2**

12 Data collection and modeling are currently underway and results will be reported in a  
13 future ATR.

## 14 **16.4 Discussion**

15 This study only evaluated structures that would have an impact on migration of fish in the  
16 San Joaquin River channel and flood bypasses. This evaluation will not identify off-  
17 channel structures like diversions or gravel mining pits that have the potential for fish  
18 entrainment. In addition, tributaries to the San Joaquin River that could cause fish  
19 straying or structures that are potential barriers on the tributaries are not going to be  
20 included in this evaluation. It should be noted that Task 1 is an initial evaluation that  
21 only looked at individual factors that would affect fish passage for each individual  
22 structure. The cumulative effects of each structure on fish migration were not evaluated  
23 during this study. The First Pass surveys were used to collect physical data of each  
24 structure including measurements and photographs.

25 Sites that were identified as Green were mostly bridges with a natural bottom where the  
26 bridge flow opening was greater or equal to the channel width. Gray sites were typically  
27 low flow crossing or channel weirs (natural and man-made) with jumping heights that  
28 would be greater than two feet at some flows. Additional Gray sites included any bridges  
29 and culverts that need hydraulic modeling to determine profile slopes and velocities.  
30 Typical Red sites were structures that were gated or known barriers due to the structures  
31 height or outlet drop.

32 This First Pass evaluation is only an initial evaluation for many of these structures and is  
33 not intended to gather all the information for hydraulic modeling. Task 2 evaluates Task  
34 1 structures that are considered as Gray and a select few Red that require additional  
35 evaluation and will lead to Task 3 of the San Joaquin River Restoration Program's Fish  
36 Passage Evaluation. Task 2 will include the evaluation and collection of additional  
37 information on the structure to develop hydraulic models; Task 3 will evaluate alternative  
38 designs to improve the passage characteristics of a structure. Those locations that are  
39 categorized as Green will no longer be evaluated and are not considered a fish passage  
40 barrier to fish at all life stages.

1 **16.5 Conclusions and Recommendations**

2 This report described the initial evaluation completed during Task 1 to determine whether  
3 structures could be initially identified as a fish passage barrier that impede migration of  
4 juvenile and adult salmon and other native fish within the San Joaquin River restoration  
5 area. The result of the analysis was an identification of each structure as Green, Gray, or  
6 Red, to signify whether it is likely a barrier to fish migration.

7  
8 At the completion of these analyses, it is expected that a priority list of structures to  
9 replace or modify will be developed with coordination between fisheries experts to  
10 identify preliminary passage capability, and engineering expertise to measure and  
11 describe the barriers. These priorities will then be recommended to the SJRRP for  
12 inclusion as a Paragraph 12 action in the Settlement.

13 **16.6 References**

14 CDFG. (1998, February). California Department of Fish and Game. *California Salmonid*  
15 *Stream Habitat Restoration Manual, Third Edition* . Inland Fisheries Division.  
16  
17 CDFG. (2002). *Culvert Criteria for Fish Passage*. California Department of Fish and  
18 Game.  
19  
20 NMFS. (2001, September). National Marine Fisheries Service. *Guidelines for Salmonid*  
21 *Passage at Stream Crossings* . Santa Rosa, California: National Marine Fisheries Service,  
22 Southwest Region.  
23  
24 NMFS. (2008, February). National Marine Fisheries Service. *Anadromous Salmonid*  
25 *Passage Facility Design* . Portland, Oregon: NMFS, Northwest Region.  
26  
27 SJRRP. (2010a, November). *Fisheries Management Plan* . San Joaquin River Restoration  
28 Program.  
29  
30 SJRRP. (2010b, November). *Final 2011 Agency Plan* . San Joaquin River Restoration  
31 Program.  
32 USACE. (2005). River Analysis System. *HEC-RAS, Version 3.1.3* . Davis, California:  
33 United States Army Corps of Engineers, Hydrologic Engineering Center.  
34

35

# 17.0 Fall-Run Captive Rearing Update

## 17.1 Introduction

The Fisheries Management Plan of the San Joaquin River Restoration Program (Program) (FMWG 2010a) sets population goals for Chinook salmon (*Oncorhynchus tshawytscha*) to achieve the Restoration Goal of restoring self-sustaining populations of wild spring- and fall-run Chinook salmon to the San Joaquin River. The Fisheries Implementation Plan (FIP) (FMWG 2010b) prioritized studies to address information needs for fish restoration. The FIP identified the Captive Rearing Study as a high priority prior to the reintroduction of salmon which is required by the Stipulation of Settlement by December 31, 2012 (NRDC vs. Rodgers 2006). The study is also identified in the Program's Hatchery and Genetic Management Plan (HGMP) which was submitted to NOAA Fisheries as an Appendix to the 10(a)1(A) Enhancement of Species permit application. The Program analysis of how best to accomplish the fish Reintroduction Goals is described in the Program's Stock Selection Strategy, Reintroduction Strategy, and HGMP.

Through this process it was recognized as a group that the federal and state protection of the remaining spring-run Chinook in California will significantly limit their availability to the Program. Successful restoration will require a sufficient number and continuous supply of donor fish for restoration. In order to achieve this without negative impact to the donor populations, it was determined that a captive rearing program will be used as a major component of restoration in combination with other non-hatchery reintroduction strategies.

Captive rearing has been successfully used to increase depleted numbers of salmon nationwide; including wild sockeye salmon in the Redfish Lake Recovery Program (Hebdon *et al.* 2004), the USFWS Winter-run Chinook Salmon Program, and it is currently in use by CDFG's Russian River Coho Recovery Program.

Due to the technical challenges experienced by these programs and the time required to establish new hatchery facilities, a pilot-scale interim facility was proposed for practice rearing of non-listed salmon to refine rearing techniques and protocols prior to handling ESA listed fish. The facility would also provide a staging location for other studies and be used for rearing spring-run Chinook while full-scale hatchery facilities are under construction.

Therefore, a pilot-scale interim conservation facility (Interim Facility) was developed in the fall/winter of 2010/2011 adjacent to the San Joaquin Fish Hatchery (Friant, CA) and small group of fall-run Chinook from Merced River Hatchery were introduced to begin captive rearing investigations.

1 **17.2 Methods**

2 1. Spawning

3 During the 2010 fall-run Chinook spawning season, 55 individual matings were  
4 performed at CDFG's Merced River Hatchery. Matings occurred on the 1<sup>st</sup>, 11<sup>th</sup>, 18<sup>th</sup> and  
5 22<sup>nd</sup> of November. According to the standard practices at the hatchery, individual  
6 females were crossed with between 1-4 males depending on the size and fecundity of the  
7 female, resulting in several half-sibling crosses. Females were mated with males of an  
8 equal or greater size. Tissue samples from each adult were collected and sent to the  
9 CDFG's Anadromous Resources Tissue Archive in Rancho Cordova, CA. A sample of  
10 between 50-200 newly fertilized eggs were segregated from each cross, placed in a  
11 cheese cloth pouch and suspended in a five-gallon bucket with flowing hatchery water.  
12 Eggs were disinfected with iodophore for approximately 15 minutes and were allowed to  
13 water harden for 1 hour. Eggs were then counted and transferred to vertically stacked  
14 incubator trays that were fitted with 4-8 partitions to accommodate the small number of  
15 eggs. Each stack of trays was supplied with approximately 5 gallons per minute of water  
16 flow and covered with opaque plastic panels to minimize light exposure. After  
17 approximately 30 days when eggs developed a strong eye, eggs were addled and 10 eggs  
18 were separated from each cross and combined

19

20 2. Hatching and Quarantine

21 On December 10 and 27, 2010, a total of 550 eggs were transferred to the CDFG  
22 Silverado Fisheries Base (Yountville, CA) for hatching and quarantine. Eggs were  
23 disinfected on arrival with iodophore and placed in vertically stacked incubator trays for  
24 hatching. Once hatched and eggs sacks were nearly completely absorbed, fry were  
25 transferred to aluminum rearing troughs. Approximately thirty days prior to  
26 transportation, 60 juveniles were sacrificed for pathology clearance by CDFG's Fish  
27 Health Laboratory in Rancho Cordova and found clear of all major pathogens.

28

29 3. Transportation of Juveniles

30 On March 11, 2011, fish were transferred to the Interim Facility using a 500 gallon  
31 double-walled insulated aluminum tank (Aquanearing INC, San Diego, CA) equipped  
32 with two mechanical aerators (Fresh-flo Corporation, Sheboygan, WI) and pure oxygen  
33 gas supplied from pressurized cylinders through two ceramic micro-bubble diffusers  
34 (Point Four Systems, Coquitlam, BC). Oxygen levels were maintained at or above  
35 saturation during transport. At the Interim Facility, fish were divided into two 3-ft  
36 diameter x 30-in deep fiberglass circular tanks. Oxygen, temperature and feed quantity  
37 were measured daily.

38

39 4. PIT Tagging

40 On May 25, 2011, fish were anaesthetized using 50 mg/L of tricaine methanesulfonate  
41 (MS-222); weighed, measured and tagged by intraperitoneal injection (IP) using 12 mm



1 preloaded Passive Integrated Transponder (PIT) tags. After tagging, fish were transferred  
2 to a single 6-ft diameter x 4-ft circular fiberglass tank.

### 3 **17.3 Results**

#### 4 1. Mortality/Survival Data

5 Survival from eyed egg stage to May 25, 2011	90.2%
6 Transportation Mortality (Yountville to Friant, 3 total)	0.67%
7 Mortality during PIT Tagging (2 total)	0.45%

8

#### 9 **2. Beginning Biologic Data (March 11, 2011)**

10 Total Weight	639 grams
11 Number of Fish	450
12 Average Fish Weight	1.4 grams

13

#### 14 **3. Growth Data (to May 25, 2011)**

15 Growth Period	74 days
16 Total Weight	6,562 grams
17 Average Weight (N=442)	14.8 grams
18 Average Fork Length	106 mm
19 Average Condition Factor	1.21
20 Total Gain (adjusted for mortality)	5,931 grams
21 Total Amount Fed	5,045
22 Feed to Gain Ratio (wet weight)	0.85
23 Fin Quality	Excellent

24

#### 25 **4. Rearing Conditions**

26 Rearing Density (LB fish/ft <sup>3</sup> volume/inch, max = 0.15)	0.129
27 Dissolved Oxygen (% of Saturation)	< 96%
28 Temperature Range (March 11-May 25)	48.8-54.9F

29

1 **17.4 Discussion**

2 The Captive Rearing Study has proven to be a valuable resource for testing new  
3 equipment, refining conservation practices and investigating existing conditions.  
4 Conservation hatcheries are a relatively new invention and it is reported that no  
5 conservation hatcheries existed prior to 1999 (Flagg and Nash 1999). This first phase of  
6 investigation has focused largely on facility development and is ongoing. Because of  
7 current water use limitations at the facility, water recirculation technology will be  
8 increasingly utilized until permitting and contracting is completed for acquiring  
9 additional water.

10 To date, fish survival from hatch has been high (90.2%). All mortality since transfer to  
11 the Interim Facility was associated with handling, with no indication of disease. High  
12 survival rates are likely the result of low densities, high dissolved oxygen levels and  
13 moderate temperatures and are indicative of good conditions for rearing trout and salmon  
14 on upper San Joaquin River water. Growth rate appears adequate as indicated by the  
15 moderate conditions factor (1.21) and healthy appearance of the fish. The Feed:Gain  
16 ratio (0.85) appears normal and indicates minimal that feed waste and feed is being well  
17 utilized for growth. Tank density began to approach the maximum of 0.15 (LB fish/ft<sup>3</sup>  
18 water/inch fish) and fish were transferred to a larger rearing tank following PIT tagging.  
19 Fish were PIT tagged on May 25, 2011 with minimal loss.

20 Growth rate modulation will become increasingly critical this next year for controlling  
21 sexual development. High growth rates are known to trigger male sexual maturation  
22 (precocity) during the first year and conversely, low growth rates can negatively impact  
23 female egg quality and fecundity. Therefore, in the coming months, each fish will be  
24 tissue sampled for genetic analysis and gender identification through the UC Davis  
25 Genomics Variation Laboratory. In addition, at age one and annually thereafter, a  
26 portable ultrasound unit will be used to assist with monitoring gonadal development.  
27 Fish will be separated according to gender. Male growth rates will be reduced to prevent  
28 precocity and female growth rates will be increased moderately to promote healthy egg  
29 development.

30 **17.5 Conclusions and Recommendations**

31 The Captive Rearing Study is proving to be valuable for testing new equipment, refining  
32 rearing techniques and identifying existing conditions for captive. The following are  
33 recommendations for the following year:

- 34 • Implement water recirculation technology to maximize available water until  
35 contracting and permitting is completed for additional water.
- 36 • Identify target a growth rates to minimize male precocity and maximize egg  
37 quality and fecundity.
- 38 • Investigate conservation rearing practices aimed to minimize hatchery induced  
39 selection.

- 1           • Closely monitor summer water temperatures and identify any negative effects  
2           associated with high temperatures.

3   **17.6 References**

- 4   Flagg, T. A., and C. E. Nash (eds). 1999. A conceptual framework for conservation  
5       hatchery strategies for Pacific salmonids. U.S. Dep. Commer., NOAA Tech. Memo.  
6       NMFS - NWFSC-38.
- 7   FMWG 2010a. Fisheries management Plan: a framework for adaptive management in the  
8       San Joaquin River Restoration Program. 147 pages plus appendices.
- 9   FMWG 2010b. Fisheries Implementation Plan. Prepared for the San Joaquin River  
10   Restoration Program.
- 11   Hebdon, J. L., P. A. Kline, D. Taki, and T. A. Flagg. 2004. Evaluating reintroduction  
12       strategies for Redfish Lake sockeye salmon captive broodstock progeny. American  
13       Fisheries Society Symposium 44: 401-413.
- 14   NRDC vs. Rodgers, et al. 2006. Stipulation of Settlement. 80pp.

15

# 1 **18.0 2010 Baseline Soil Salinity**

## 2 **18.1 Introduction**

3 This report was prepared to document soil salinity sampling operations near the San  
4 Joaquin River in the late February to early May period of 2010. Seventy nine sites were  
5 evaluated to determine baseline soil salinity levels before and shortly after the San  
6 Joaquin River Restoration Program began to increase flows in the river. These sites are  
7 located throughout a very large area of potentially impacted lands. An additional eight  
8 sites were sampled and logged in September in response to a landowner request. These  
9 sites and a few other selected sites may be sampled in the spring of 2011 and added to the  
10 soil salinity database. A copy of all the soil profile logs sampled in the spring of 2010, a  
11 list of abbreviations used on the soil profile logs, and a map showing the location of the  
12 soil salinity sites are appended to this report.

13  
14 Reclamation sampled 77 of the baseline soil salinity sites during late February, March,  
15 April, and early May of 2010. Some of these sites are offset 200-300 feet from nearby  
16 observation wells while some additional sites were selected based on field observations,  
17 access considerations, and crop type. All sites were benchmarked with a hand held GPS  
18 unit. Estimated position errors were commonly less than 20 feet. Electromagnetic (EM)  
19 soil electrical conductivity surveys were also conducted at nearly all sites. Sites were  
20 commonly located at least 200 feet into irrigated fields. Copies of the soil salinity data,  
21 soil profile logs, and EM38 signal data are attached. All the sites are scheduled to be  
22 resampled in the spring of 2012 with some selected sites resampled periodically to  
23 determine soil salinity trends over time. The primary purpose of the soil sampling was to  
24 determine baseline soil salinity levels prior to the increase in San Joaquin river flows.

## 25 **18.2 Methods**

26 Soil Sampling was typically done by a two to three man crew under the direction of the  
27 soil scientist in charge. An EM38 survey was conducted within a 100 foot radius of the  
28 initial selected site. At least 12 paired EM measurements were made. The EM38 in the  
29 horizontal position (EMh) generally measures the bulk soil electrical conductivity to a  
30 depth of about 30 inches while the vertical EM signal (EMv) generally reflects the bulk  
31 electrical conductivity of the 0-60 inch soil depth. Both readings can be used to estimate  
32 the soil salinity of the 0-36 inch soil zone. The number of measurements can be  
33 increased if the survey area has variable readings. The EM readings were averaged and  
34 adjusted for soil temperature. The final sampling site was placed directly under a pair of  
35 EM measurements. Measurements at the sampling site were commonly well within the  
36 range of readings measured surrounding the site. Sites with unusually high or low EM  
37 readings were usually not chosen for central boring sites.

38

Reports  
Appendix

1 The EM38 has several advantages. It can provide many real time soil salinity  
2 measurements. The instrument measures bulk soil electrical conductivity of an area about  
3 6 feet long, 5 feet deep and about 2.5 feet wide. The EM survey provides real time  
4 information on soil salinity levels, salt distribution in the profile, and spatial variation of  
5 soil salinity within an area surrounding the boring site.

6  
7 The soil scientist carefully hand augured the central boring and collected soil samples at  
8 0-12 inches; 12-30 inches; and 30-60 inches. The soil was examined and a soil profile log  
9 was prepared using the USDA soil textural system and nomenclature. Special emphasis  
10 was given to depth of mottling, and or gleying, capillary fringe thickness; and depth to  
11 shallow groundwater.

12  
13 A separate multi increment spatial composite soil sample of surface soil (0-1 foot) was  
14 collected from an area within a 100 foot radius of the central boring. These samples  
15 contained at least 15 increments and some contained 30 increments. These samples were  
16 collected with a one inch diameter Dakota probe or in some cases an Oakfield probe.  
17 Baseline soil samples in field crops and row crops were collected in a stratified random  
18 manner to insure that the top, sides, bed shoulders, and furrows were represented in the  
19 composite surface soil samples. Orchard and vineyard areas were carefully sampled to  
20 avoid underground plastic pipe manifolds and trench backfill; and to insure that the  
21 spatial composite soil samples included increments collected from near the emitter, near  
22 the center of the tree rows, and areas near the edge of the tree canopy. In some cases soil  
23 sampling procedures were customized for each orchard or vineyard depending on the  
24 type of irrigation system used. Replicate soil salinity samples were also collected from  
25 the area within a 100 foot radius around some of the boring sites. A 0-12 inch soil sample  
26 was also collected from the central site. This sample was mainly used for EM meter  
27 calibration. The multi increment surface soil composite soil samples were used for most  
28 evaluations including establishment of baseline soil salinity values and estimation of crop  
29 yield potential.

30  
31 Soil samples were sent to the Fruitgrower's Laboratory in Santa Paula, California for  
32 analysis. A screenable testing procedure was used. If the ECe exceeded 4dS/m or the pH  
33 paste was 8.5 or higher a Sodium Adsorption Ratio (SAR) analysis was requested.

34  
35 Quality assurance / Quality control of laboratory salinity data was provided by  
36 Reclamations Sacramento office. All data presented in this report met or exceeded  
37 Reclamation acceptance criteria.

38  
39 Soil salinity and sodicity data are presented in appendix A. Copies of the soil boring logs  
40 are attached to this report as appendix B.

#### 41 **18.2.1 EM38 Salinity Surveys**

42 These surveys were generally conducted in a circular area within a 100 foot radius of the  
43 central boring site. At least 12 pairs of EM measurements were collected at each site in a  
44 stratified random manner. The EMh reading measures soil salinity in roughly the top 30  
45 inches of soil while the EMv reading measures soil salinity in the top 60 inches of soil.

Reports  
Appendix

1 The EMh signal is strongest near the soil surface while the maximum EMv signal comes  
2 from about 16 inches below the soil surface. The EMh signal strength is sometimes  
3 considered a good representation of soil salinity for plant growth and salt tolerance  
4 evaluations since the signal strength from different soil depth intervals tends to follow  
5 plant water uptake patterns. Both the EMh and EMv readings can be used to estimate  
6 bulk soil salinity levels in the 0-36 inch depth zone. The signal data can be used to  
7 estimate bulk soil electrical conductivity however it is difficult to predict soil saturation  
8 extract values from EM data. Soil texture, temperature, and soil moisture content, as well  
9 as soil salinity levels affect the EM signal data. All EM38 measurements collected at the  
10 sites were adjusted for soil temperature and averaged. Normal classical statistics were  
11 used to determine the 95 percent confidence range. The percentage of inverted soil  
12 salinity readings is also listed since an increase in the percentage of inverted soil salinity  
13 profiles is judged an important indication of declining land productivity symptomatic of  
14 shallow groundwater and poor drainage conditions.

15  
16 Appendix D presents soil characteristics found at the 79 sampling sites. The depth to  
17 mottling is an indication of seasonal high water table levels. Mottling at some of the sites  
18 could be a relict condition from the pre development period before major dams, flood  
19 control projects, irrigation projects, and extensive groundwater pumping partially drained  
20 the area. Soil salinity profiles are termed regular if soil salinity increases with depth. Soil  
21 salinity profiles are termed inverted if harmful levels of soil salinity are present near the  
22 soil surface and salinity decreases with depth. Profiles were termed uniform if no salinity  
23 pattern could be determined and soil salinity levels were below the level of concern  
24 throughout the profile. The capillary fringe zone includes soils above field capacity. Field  
25 observations were supplemented by gravimetric soil moisture measurements. Generally if  
26 the gravimetric soil moisture content was more than 50 percent of the saturation extract  
27 moisture content the soil was considered to be above field capacity. In some cases  
28 elevated moisture levels are caused by boundary conditions associated with soil  
29 stratification and layering. The capillary fringe thickness is not the same as the total  
30 capillary rise from a water table. Capillary forces can move water above the capillary  
31 fringe zone. The rise of salts into surface soils is evidence of upward movement of water  
32 and salts into the active root zone. This tends to encourage formation of an inverted soil  
33 salinity profile late in the growing season following the last irrigation event.

### 34 **18.2.2 Soil Salinity Gypsum Content Adjustment**

35 Limited soil testing suggests that most soils in the lower reach 4a area with an E<sub>Ce</sub> over  
36 about 4dS/m contain natural or applied gypsum. Saline lands in reach 2b appear to have a  
37 different E<sub>Ce</sub> / gypsum level relationship. Gypsum and sulfur are periodically applied to  
38 surface soils on some lands. Sulfur reacts with soluble calcium dissolved from lime  
39 (CaCO<sub>3</sub>) in the soil to form gypsum. Since gypsum is a sparingly soluble salt relatively  
40 more gypsum is dissolved in the saturation extract than is dissolved in the soil water.  
41 Therefore FAO annex 1(2) and most other salt tolerance data sources (5) recommend  
42 subtracting a value of 2 dS/m from the saturation extract E<sub>Ce</sub> value prior to using salt  
43 tolerance data to estimate yield potential. When site specific gypsum data are not  
44 available it is recommended that the SJRPP gradually incrementally factor in the gypsum  
45 adjustment from an E<sub>Ce</sub> of 3.5 to an E<sub>Ce</sub> of 7.5. At an E<sub>Ce</sub> of 7.5 the full 2dS/m

1 adjustment would be used. The gypsum adjustment should only be applied to soil layers  
 2 that exceed an ECe of 3.5 and have over 15 meq / liter of soluble calcium in the  
 3 saturation extract. The ECe of the soil layers containing gypsum should be adjusted prior  
 4 to averaging soil ECe values with the other soil depth zones.

5  
 6 Several soils in reach 4a with an ECe over 4 and more than 20 meq / liter of calcium in  
 7 the saturation extract were tested for calcium in a 1-5 soil / water extract. If significantly  
 8 more calcium was dissolved in the 1.5 extract on a dry soil weight basis then the soils  
 9 were assumed to contain residual gypsum. Additional soil testing for gypsum content is  
 10 planned for future soil sampling events.

11 **18.2.3 Soil Salinity Weighting Procedures**

12 Crop yield potential can be estimated by comparing active root zone soil salinity values  
 13 with crop salt tolerance tables. Prior to comparison of ECe values to crop salt tolerance  
 14 tables the ECe values should be weighted to approximate crop water uptake patterns. (2)  
 15 These values are termed Crop salt tolerance (CT) ECe.

16  
 17 Soil salinity data should be weighted to reflect the crops water uptake pattern from the  
 18 root zone. Typical crop water uptake patterns in well drained soils are presented below:  
 19 (2)

20  
 21 **Table 18-1: Crop Water Uptake**

Root Zone Quadrant	Water Uptake %	Percent of CT ECe
1 <sup>st</sup> (surface soils)	40	40
2 <sup>nd</sup>	30	30
3 <sup>rd</sup>	20	20
4 <sup>th</sup>	10	10

22  
 23 The water uptake distribution presented above may be used for field crops on some well  
 24 drained sites where soils were sampled at one foot intervals. For crops with a 4 foot root  
 25 zone the ECe values may be weighted to reflect the 40, 30, 20, 10 water uptake pattern.  
 26 Most of the salinity sites sampled by Reclamation were sampled at 0-12, 12-30 and 30-60  
 27 inch depth intervals. The soil salinity weighting procedures recommended for use to  
 28 estimate crop salt tolerance for sites sampled by Reclamation are presented below.

29  
 30 For sites affected by shallow groundwater with inverted soil salinity profiles the SJSRP  
 31 used a double weighted surface soil value and a single weighted 12-30 inch value. For  
 32 well drained sites the ECe used was an average value for the 0-12; 12-30, and 30-60 inch  
 33 zones. When these procedures are used the 0-12 inch zone is weighted higher per unit of  
 34 depth than the deeper zones. Weighting the shallow soil layers heavier is appropriate  
 35 since plants use most of their moisture from shallower soil layers. The depth weighted  
 36 soil salinity per unit depth of soil when using these methods is presented below:

37  
 38 **Table 18-2: Poorly Drained Soils (inverted soil salinity profile)**

Depth (inches)	Percent of CT ECe
----------------	-------------------

0-12	75
12-30	25
30-60	0

Table 18-3: Well drained soils or soils with artificial drainage (regular soil profile)

Depth (inches)	Percent of CT ECe
0-12	49
12-30	32
30-60	19

## 18.3 Results

### 18.3.1 Depth to and thickness of capillary fringe zones

The thickness of capillary fringe zones was measured in 32 sites during the March / April period at sites where water was encountered. The average capillary fringe thickness was 14.6 inches. The 95 percent confidence range was 11.8 -17.4 inches. Observations of capillary fringe ranged from 2 to 34 inches. In a few cases water table depth was estimated. See Appendix D for detailed results.

### 18.3.2 Estimation of Measurement Error and Soil Variation

Replicate soil samples and replicate EM surveys were conducted at selected sites to estimate field sampling error. Paired soil samples and EM measurements were also evaluated about 15-20 feet apart. These exercises were conducted to determine if the sampling technique and the number of observations was adequate to overcome spatial variation. Replicate soil samples and EM surveys were conducted in the same manner, on the same area, in the same time period by different personnel. The relative percent difference (RPD) between the two readings is presented below. A summary of findings for these surveys is presented below:

Table 18-4: Relative Percent Difference of Replicate Samples

Type	Number	Average RPD	RPD Range
Field Replicate Soil Samples	12	13.7	1.0 – 40.7
Replicate EM surveys - EMh	7	3.8	0.8 – 9.4
Replicate EM surveys - EMv	7	3.7	0.3 – 6.9
Paired soil samples	5	13.3	9.5 – 24.1
Paired EM readings – EMh	8	13.0	0 – 38.8
Paired EM readings - EMv	8	16.6	0.3 – 44.5



1 The low RPD readings for EM survey replicate measurements are partially due to the  
 2 large volume of soil measured at each site. The large volume measurement eliminates  
 3 much of the micro variation present in pedon sized soil volumes.

4 **18.3.3 NRCS Soil Series Interpretive Data**

5 The table presented below lists common soil types along the San Joaquin River. Soil  
 6 interpretive data were taken from the official soil series descriptions on the NCRS  
 7 internet site.

8  
 9 Examination of soil survey maps and an internet search for official soil series  
 10 descriptions was conducted. The soils listed below are the most common soils near the  
 11 river in reaches 2b, 3 and 4. The ranges of depth to water are for late winter and spring.  
 12 The depth to mottling probably indicates the highest level of seasonal saturation prior to  
 13 regional drainage, flood control projects, and increased groundwater pumping in some  
 14 areas. A summary of soil characteristics based on a review of the NRCS soil profile  
 15 descriptions for the soil series are presented below.

16  
 17 **Table 18-5: NRCS Soil Series Information**

Soil series	Texture USDA Plow layer	Water table depth (inches)	Depth to iron stains; Mottles (inches)	Affected by excess Salinity / Sodictity
Dello	Sand	10-50	6	No
Gepford	Clay	30-72	12	Yes
Armona	Loam	24-72	9	Yes
Turlock	Sandy loam	0-12	3	Yes
Pozo	Loam	Over 60	Over 60	Yes
Fresno	F sandy loam	Over 60	24	Yes
Traver	F sandy loam	Over 60	38	Yes
Tachi	Clay	48-72	14	Yes
Waukena	F sandy loam	Over 60	Over 60	Yes
Tranquility	Clay	48-72	31	Yes
Merced	Clay loam	48-72	48	Yes
Chino*	Silt loam	40-60	46	No
Columbia*	F sandy loam	20-48	26	No
Bolfar*	Clay loam	36-60	25	No
Palazzo*	Sandy loam	42-60	14	No
Grangeville*	F sandy loam	24-48	11	No
Foster	Sandy loam	36-60	16	No
Temple	Loam	36-60	12	No
Elnido*	Sandy loam	Over 42	10	No
Bisgani	Loamy sand	Over 42	14	No
Dos palos	Clay loam	36-60	27	No
Kesterson	Sandy loam	12-36	26	Yes
Rossi	Clay loam	36-60	42	Yes
Escano	Clay loam	36-60	17	No

1       \*extensive soil near river

2

3       The NRCS soil descriptions indicate nearly all soils are affected by shallow water tables  
4       in the late winter and early spring. Large dams and flood control projects have greatly  
5       reduced the flooding potential and extensive groundwater pumping for irrigation has  
6       lowered the water table relative to historic conditions at some locations. Based on a  
7       comparison of the sampled sites to the historic conditions described in the NRCS soil  
8       surveys it appears that drainage conditions have improved in most areas with extensive  
9       groundwater pumping. Conditions seem to be somewhat stable in portions of the lower  
10      reach 4a and 4b areas irrigated with surface waters. Areas near the eastside bypass in  
11      reach 4B seem to be somewhat more poorly drained at the present time than they were  
12      under historical conditions.

## 13      **18.4 Discussion**

14      The interpretive information in this report is based on the author's interpretation of the  
15      data, field observations throughout the study area, and 30 years of experience assessing  
16      the suitability of lands and soils for irrigation project development. Interpretation of this  
17      data by other soil scientists, agronomists, agricultural professionals, or growers may be  
18      different than the authors.

19

20      Since the soil sampling in Reaches 2, 3, and 4A was done after the initial rise in river  
21      flows these samples may not be a true baseline of preflow conditions. Reach 4B sites  
22      were sampled prior to water releases into the old channel of the San Joaquin River. The  
23      assessment of baseline conditions is also complicated by the recent shift from gravity to  
24      drip irrigation in some fields.

### 25      **18.4.1 Root Zone Depth**

26      The baseline soil salinity borings were commonly evaluated to a depth of 5 feet. In a few  
27      cases the borings were extended in wet soils to determine the depth of the water table.  
28      Since many of the soil borings were in fallow fields the depth and abundance of roots was  
29      not commonly noted on the soil logs, however a search of the soil logs did indicate that  
30      hardpan layers appeared to limit root zone depth at some sites.

31

32      Reclamation drainage criteria (1) generally provide for a four foot unsaturated root zone  
33      midway between the drains for field crops. This drainage depth is associated with about a  
34      95 percent yield potential. Although drain depth for deep rooted crops (orchards,  
35      vineyards) is not given, the graph on page 139 of the Reclamation Drainage Manual (1)  
36      suggests that deep rooted crops require an unsaturated root zone about 2 feet deeper than  
37      shallow rooted crops. Based mostly on Reclamation experience the initial root zone  
38      action levels were 4 feet for field crops and 6 feet for orchards.

39

40      Depth to root zone information was evaluated for many field and vegetable crops in the  
41      draft SSJJR seepage management plan (4) however a depth of four feet is recommended  
42      by the Reclamation Drainage Staff for the root zone depth for shallow rooted crops since

1 crop rotation is commonly practiced and the unsaturated root zone should accommodate  
2 most crops in the rotation including alfalfa. Reclamations design depth for drains in field  
3 crop lands has historically been 4 feet.

4  
5 Deep rooted crops include grapes and almonds and most deciduous orchards however  
6 root zone depth for pomegranates and pistachios may be shallower than most other  
7 orchard crops.

8  
9 It is recommended that future soil evaluations include the depth and abundance of roots  
10 especially in orchard areas. The depth of soil borings in orchards may be extended to  
11 better evaluate crop root zone depth.

#### 12 **18.4.2 Soil Salinity Monitoring Thresholds**

13 Soil salinity in irrigated lands is usually at dynamic equilibrium with factors such as  
14 irrigation water salinity, soil characteristics, deep percolation volume, leaching fractions,  
15 and climate determining the soil salinity levels. Normally the active root zone is about 1.5  
16 times the EC of the irrigation water. Well drained soils under efficient irrigation practices  
17 the E<sub>Ce</sub> of the soil will increase with depth and is commonly 5-10 times higher at the  
18 bottom of the root zone than at the soil surface. Net water and salt movement is  
19 downward in well drained soils. When stagnant shallow groundwater is present this  
20 downward movement is impeded and water and salts will move upward in response to  
21 forces created by evaporation and transpiration near the soil surface. This process often  
22 creates an inverted soil salinity profile in poorly drained lands where soil salinity is  
23 highest in surface soil layers and decreases with depth.

24  
25 Three types of soil salinity threshold levels are presented below. These are not action  
26 levels as are groundwater measurements but are monitoring thresholds (4). When these  
27 threshold levels are exceeded, increased soil monitoring may be warranted however no  
28 short term flow adjustments are recommended.

29  
30 The first monitoring threshold deals with soil salinity levels in the early season. Soil  
31 salinity levels should be favorable in springtime following leaching incidental to winter  
32 rains and pre irrigation. Salinity levels are critical during the germination and emergence  
33 period. The SJRRP surface soil salinity level of concern for the March, April, early May  
34 period is 2 dS/ m in the top foot of soil.

35  
36 Soil salinity can also limit crop yields throughout the growing season. The monitoring  
37 threshold levels presented below are based on the salinity level associated with full yield  
38 potential for tomatoes. (2.5 dS/m). This level of salinity would permit about 96 percent of  
39 the yield potential for alfalfa. Generally any soil salinity level exceeding an E<sub>Ce</sub> of 2.5 in  
40 the top 30 inches of soil would exceed this monitoring threshold.

41  
42 A third monitoring threshold is based on the percentage of inverted soil salinity profiles  
43 measured in an EM survey. Any significant increase in the percentage of inverted soil  
44 salinity profiles is judged to be a cause for concern. When soil salinity is higher in soil  
45 surface layers than at depth the soil salinity profile is termed inverted. Inverted soil

1 salinity levels are indicative of poor drainage conditions and sites adversely affected by  
2 shallow groundwater. In some cases drip irrigation appears to contribute to inverted soil  
3 salinity profiles late in the growing season. Gypsum applications to surface soils may also  
4 temporarily cause an inverted soil salinity profile.

### 5 **18.4.3 Irrigation system types and crop type factors**

6 Drip irrigated fields are more difficult to obtain representative samples than gravity  
7 irrigated fields.(6) Soil salinity patterns, buried infrastructure, and in some cases wire  
8 trellises and/or metal stakes were present in some tracts. EM surveys and surface soil  
9 sampling patterns took these issues into account. Drip irrigated tomatoes and melon fields  
10 were sampled with half the sites in the furrows and half of the sites near the shoulder of  
11 the crop beds. Sometimes these zones were sampled separately to determine soil salinity  
12 patterns. EM38 surveys in orchards and vineyards were also conducted in order to  
13 measure salinity in various positions relative to the tree and drip emitter locations.  
14 Growers tend to schedule drip irrigations based on crop water use and little leaching of  
15 salts takes place during the growing season. Leaching that does occur is confined to areas  
16 near the drip emitters. Salts tend to accumulate near the soil surface at the margins of the  
17 areas wetted by the drippers or micro sprinklers.(6) Drip irrigated sites are sometimes  
18 leached during the off season by winter rains and /or gravity or sprinkler irrigation  
19 methods.

## 20 **18.5 Conclusions**

### 21 **18.5.1 Determination of Long Term Soil Salinity Trends**

22 Long term springtime soil salinity trends will be determined based primarily on the 0-12  
23 inch spatial composite surface soil samples and the EM38 signal data that is adjusted for  
24 soil temperature. Normally the 95 percent confidence level is used to evaluate significant  
25 soil salinity trends however the 70 per cent confidence range and/ or other ranges can  
26 also be determined.

27  
28 Soil salinity levels in the March /April period will be used for this comparison. This time  
29 period is critical since it is usually the lowest soil salinity level of the season and is the  
30 salinity level present just before planting. Crop germination and emergence is a critical  
31 time period for crops. (5) Winter rains and in some cases pre-irrigation has leached the  
32 soils and tends to even out soil salinity levels. Soils typically are near field capacity and  
33 are relatively easy to sample in the March / April period. EM38 measurements are also  
34 easiest to interpret when the soil is near field capacity and surface soils are moist. Soil  
35 salinity levels later in the growing season tend to change in response to irrigation and  
36 drying cycles due to crop water use. Salinity micro variation patterns in soils also become  
37 more pronounced later in the crop season. Soil salinity is normally highest following crop  
38 moisture extraction after the last irrigation event.

39  
40 The soil salinity sites are scheduled for resampling in 2012. Selected sites that exceed the  
41 salinity levels of concern are near wells that have exceeded groundwater action threshold

1 levels, or are requested for resampling by landowners, may be resampled during the  
2 interim years or in different seasons of the year.

3 **18.5.2 Recommendations for Future Investigations**

- 4 - Include root abundance and depth on future soil evaluations.
- 5 - Evaluate soil borings to deeper depths in orchards.
- 6 - Possibly evaluate some backhoe pits for root depth and capillary fringe thickness
- 7 - Determine gravimetric soil moisture levels in the capillary fringe zone
- 8 - Possibly use tensiometers, transiometers, or other appropriate instrumentation to
- 9 help determine the thickness of capillary fringe zones in different times of the
- 10 year.
- 11 - Sample additional salinity sites and resample existing sites in 2011 in areas where
- 12 soil salinity exceeds the level of concern or where shallow groundwater has
- 13 encroached on the buffer zone during the growing season
- 14 - Resample all baseline sites in the spring of 2012 and evaluate soil salinity trends.
- 15 - Determine SAR and soil gypsum content on some soils in the ECe 3 to 4 range.
- 16
- 17
- 18

1 **18.6 References**

2 (1) Drainage Manual, 1993 edition, Bureau of Reclamation  
3 (2) United Nations Food and Agricultural Organization Irrigation and Drainage Paper  
4 29, Rev 1 Ayers R. S. and Westcot D. W.  
5 (3) FAO annex 1, adapted from Maas and Grattan 1999 crop salt tolerance data sets.  
6 (4) San Joaquin River Restoration Program, Seepage Management Plan, 2010  
7 (5) Testing Crops for Soil Salinity Tolerance, E. V. Maas; Proc. Workshop on Adaptation  
8 of Plants to Soil Stresses, p 234-247; 1993  
9 (6) Controlling Soil Salinity, Blaine Hanson, Dept of land, Air, and Water resources, UC  
10 Davis; internet presentation.

11  
12  
13  
14  
15  
16  
17  
18  
19  
20  
21  
22  
23  
24  
25  
26

1 **Appendix A: Soil salinity Summary data**

Site	Sample type	Depth (inches)	pH paste	ECe (dS/m)	SAR
1-10	17 increment spatial composite	0-12	6.9	0.99	
1-10	Hand augured central boring	0-12	6.79	0.64	
1-10	Hand augured central boring	12-30	7.13	0.42	
1-10	Hand augured central boring	30-60	7.18	0.49	
2-10	30 increment spatial composite	0-12	7.29	4.72	
2-10	Hand augured central boring	0-12	7.44	3.91	
2-10	Hand augured central boring	12-30	6.99	4.70	6.9
2-10	Hand augured central boring	30-60	7.27	0.50	
3-10	30 increment spatial composite	0-12	7.45	7.56	14.9
3-10	30 increment spatial composite, field replicate	0-12	7.52	6.83	13.4
3-10	Hand augured central boring	0-12	7.56	11.7	20.6
3-10	Hand augured central boring	12-30	6.98	1.96	
3-10	Hand augured central boring	30-60	7.22	1.20	
4-10	30 increment spatial composite	0-12	7.87	1.80	
4-10	Hand augured central boring	0-12	7.76	1.45	
4-10	Hand augured central boring	12-30	7.96	3.21	
4-10	Hand augured central boring	30-60	7.46	2.16	
5-10	30 increment spatial composite	0-12	7.23	4.36	5.1
5-10	Hand augured central boring	0-12	6.78	4.23	4.3
5-10	Hand augured central boring	12-30	7.23	5.41	7.2
5-10	Hand augured central boring	30-60	7.52	1.77	
6-10	30 increment spatial composite	0-12	7.12	1.49	
6-10	Hand augured central boring	0-12	6.78	1.08	
6-10	Hand augured central boring	12-30	7.08	1.42	
6-10	Hand augured central boring	30-60	7.00	1.26	
7-10	30 increment spatial composite	0-12	7.03	1.77	
7-10	Hand augured spatial composite	0-12	7.01	0.82	
7-10	Hand augured spatial composite	12-30	7.07	2.94	
7-10	Hand augured spatial composite	30-60	6.90	2.06	
8-10	20 increment spatial composite	0-12	6.88	0.96	
8-10	20 increment spatial composite, field replicate	0-12	6.87	0.95	
8-10	Hand augured central boring	0-12	6.83	0.93	
8-10	Hand augured central boring	12-30	7.32	0.71	
8-10	Hand augured central boring	30-60	6.88	1.23	
9-10	30 increment spatial composite	0-12	7.18	0.98	
9-10	Hand augured central boring	0-12	7.09	0.71	

Site	Sample type	Depth (inches)	pH paste	ECe (dS/m)	SAR
9-10	Hand augured central boring	12-30	7.35	0.36	
9-10	Hand augured central boring	30-60	7.44	0.41	
10-10	30 increment spatial composite	0-12	6.59	1.50	
10-10	Hand augured central boring	0-12	6.50	0.86	
10-10	Hand augured central boring	12-30	6.62	1.42	
10-10	Hand augured central boring	30-60	7.05	0.66	
11-10	20 increment spatial composite	0-12	7.52	1.34	
11-10	20 increment spatial composite, field replicate	0-12	7.48	1.11	
11-10	Hand augured central boring	0-12	6.92	1.08	
11-10	Hand augured central boring	12-30	7.53	1.35	
11-10	Hand augured central boring	30-60	7.61	3.10	
12-10	30 increment spatial composite	0-12	7.68	4.89	9.7
12-10	Hand augured central boring	0-12	7.98	1.12	
12-10	Hand augured central boring	12-30	7.76	2.24	
12-10	Hand augured central boring	30-60	7.69	0.28	
13-10	30 increment spatial composite	0-12	6.44	7.21	7.2
13-10	Hand augured central boring	0-12	6.79	9.70	4.9
13-10	Hand augured central boring	12-30	7.45	2.84	
13-10	Hand augured central boring	30-60	7.63	1.03	
14-10	30 increment spatial composite	0-12	7.80	2.78	
14-10	Hand augured central boring	0-12	7.74	1.56	
14-10	Hand augured central boring	12-30	7.55	4.10	6.1
14-10	Hand augured central boring	30-60	7.83	1.63	
15-10	30 increment spatial composite	0-12	7.30	0.81	
15-10	Hand augured central boring	0-12	7.42	0.74	
15-10	Hand augured central boring	12-30	7.49	1.17	
15-10	Hand augured central boring	30-60	7.54	1.18	
16-10	30 increment spatial composite	0-12	7.25	2.69	
16-10	Hand augured central boring	0-12	7.28	0.98	
16-10	Hand augured central boring	12-30	6.73	3.87	
16-10	Hand augured central boring	30-60	7.30	0.57	
17-10	24 increment spatial composite	0-12	7.97	9.23	10.3
17-10	24 increment spatial composite, field replicate	0-12	7.95	7.47	11.5
17-10	Hand augured central boring	0-12	7.80	10.9	13.5
17-10	Hand augured central boring	12-30	7.44	5.95	3.9
17-10	Hand augured central boring	30-60	7.06	1.66	
18-10	30 increment spatial composite	0-12	7.61	1.02	
18-10	Hand augured central boring	0-12	7.74	1.26	
18-10	Hand augured central boring	12-30	7.86	5.11	18.6
18-10	Hand augured central boring	30-60	8.09	0.36	
19-10	30 increment spatial composite	0-12	7.59	1.54	

Reports  
Appendix



Site	Sample type	Depth (inches)	pH paste	ECe (dS/m)	SAR
19-10	Hand augured central boring	0-12	7.38	1.27	
19-10	Hand augured central boring	12-30	7.58	6.26	11.1
19-10	Hand augured central boring	30-60	7.79	2.37	
20-10	30 increment spatial composite	0-12	7.66	1.62	
20-10	Hand augured central boring	0-12	7.41	1.84	
20-10	Hand augured central boring	12-30	7.64	3.15	
20-10	Hand augured central boring	30-60	7.43	6.38	14.3
21-10	30 increment spatial composite	0-12	7.37	2.09	
21-10	Hand augured central boring	0-12	7.51	1.38	
21-10	Hand augured central boring	12-30	7.48	0.93	
21-10	Hand augured central boring	30-60	7.46	2.38	
22-10	12 increment spatial composite	0-12	5.58	0.21	
22-10	Hand augured central boring	0-12	5.62	0.12	
22-10	Hand augured central boring	12-30	5.93	0.31	
22-10	Hand augured central boring	30-56	6.47	0.27	
23-10	30 increment spatial composite	0-12	6.41	0.69	
23-10	Hand augured central boring	0-12	6.31	0.45	
23-10	Hand augured central boring	12-30	6.83	0.54	
23-10	Hand augured central boring	30-60	7.41	0.11	
24-10	30 increment spatial composite	0-12	6.77	1.47	
24-10	Hand augured central boring	0-12	6.91	0.88	
24-10	Hand augured central boring	12-30	6.67	1.76	
24-10	Hand augured central boring	30-60	6.39	0.65	
25-10	30 increment spatial composite	0-12	7.51	1.18	
25-10	30 increment spatial composite, field replicate	0-12	7.49	1.67	
25-10	Hand augured central boring	0-12	7.52	0.8	
25-10	Hand augured offset boring, paired sample	0-12	7.70	0.74	
25-10	Hand augured central boring	12-30	7.72	0.90	
25-10	Hand augured offset boring, paired sample	12-30	7.71	0.99	
25-10	Hand augured central boring	30-60	7.86	1.17	
26-10	30 increment spatial composite	0-12	8.05	1.15	
26-10	Hand augured central boring	0-12	7.48	0.49	
26-10	Hand augured central boring	12-30	7.83	1.19	
26-10	Hand augured central boring	30-60	7.60	1.70	
27-10	30 increment spatial composite	0-12	7.36	0.93	
27-10	30 increment spatial composite, field replicate	0-12	7.29	0.95	
27-10	Hand augured central boring	0-12	7.20	0.77	
27-10	Hand augured central boring	12-30	7.40	1.54	
27-10	Hand augured central boring	30-60	7.14	2.16	
28-10	30 increment spatial composite	0-12	7.28	1.13	
28-10	Hand augured central boring	0-12	7.25	0.78	

Reports  
Appendix

Site	Sample type	Depth (inches)	pH paste	ECe (dS/m)	SAR
28-10	Hand augured central boring	12-30	7.48	0.96	
28-10	Hand augured offset boring, paired sample	12-30	7.36	0.87	
28-10	Hand augured central boring	30-60	7.24	0.84	
28-10	Hand augured offset boring, paired sample	30-60	7.37	1.07	
29-10	30 increment spatial composite	0-12	6.61	2.25	
29-10	Hand augured central boring	0-12	6.42	0.56	
29-10	Hand augured central boring	12-30	7.56	0.81	
29-10	Hand augured central boring	30-60	7.83	0.62	
30-10	20 increment spatial composite	0-12	6.88	1.87	
30-10	20 increment spatial composite, field replicate	0-12	6.78	1.89	
30-10	Hand augured central boring	0-12	7.19	0.80	
30-10	Hand augured central boring	12-30	7.57	2.02	
30-10	Hand augured central boring	30-60	7.76	1.53	
31-10	30 increment spatial composite	0-12 30x	7.04	2.90	
31-10	Hand augured central boring	0-12	7.08	0.84	
31-10	Hand augured central boring	12-30	7.44	3.39	
31-10	Hand augured central boring	30-60	7.97	0.29	
32-10	30 increment spatial composite	0-12	7.51	1.70	
32-10	Hand augured central boring	0-12	7.44	1.40	
32-10	Hand augured central boring	12-30	7.41	2.80	
32-10	Hand augured central boring	30-60	7.56	3.42	
33-10	20 increment spatial composite	0-12	7.75	1.29	
33-10	20 increment spatial composite, field replicate	0-12	7.78	1.02	
33-10	Hand augured central boring	0-12	7.76	1.35	
33-10	Hand augured central boring	12-30	7.54	3.71	
33-10	Hand augured central boring	30-60	7.41	4.67	7.1
34-10	20 increment spatial composite	0-12	7.4	1.32	
34-10	Hand augured central boring	0-12	7.31	0.73	
34-10	Hand augured central boring	12-30	7.54	1.26	
34-10	Hand augured central boring	30-60	7.67	1.8	
35-10	60 increment spatial composite	0-12	6.79	1.51	
35-10	Hand augured central boring	0-12	6.71	0.7	
35-10	Hand augured central boring	12-30	6.95	2.19	
35-10	Hand augured central boring	30-60	7.43	1.05	
36-10	20 increment spatial composite	0-12	6.77	1.94	
36-10	Hand augured central boring	0-12	6.44	0.84	
36-10	Hand augured central boring	12-30	6.65	1.49	
36-10	Hand augured central boring	30-60	7.28	0.79	
37-10	30 increment spatial composite	0-12	6.63	1.72	
37-10	Hand augured central boring	0-12	6.64	1.97	

Site	Sample type	Depth (inches)	pH paste	ECe (dS/m)	SAR
37-10	Hand augured central boring	12-30	6.61	1.6	
37-10	Hand augured central boring	30-60	7.01	1.69	
38-10	20 increment spatial composite	0-12	7.23	1.79	
38-10	Hand augured central boring	0-12	6.85	1.59	
38-10	Hand augured central boring	12-30	7.08	1.84	
38-10	Hand augured central boring	30-60	7.58	1.96	
39-10	20 increment spatial composite	0-12	7.69	1.89	
39-10	Hand augured central boring	0-12	7.64	1.36	
39-10	Hand augured central boring	12-30	7.72	2.33	
39-10	Hand augured central boring	30-60	8.10	1.93	
40-10	20 increment spatial composite	0-12	6.89	1.88	
40-10	Hand augured central boring	0-12	6.87	0.60	
40-10	Hand augured central boring	12-30	7.16	1.07	
40-10	Hand augured central boring	30-60	7.71	2.68	
41-10	22 increment spatial composite	0-12	7.53	2.37	
		22x			
41-10	Hand augured central boring	0-12	7.57	1.13	
41-10	Hand augured central boring	12-30	7.7	2.53	
41-10	Hand augured central boring	30-60	7.69	2.12	
42-10	22 increment spatial composite	0-12	6.69	1.82	
42-10	Hand augured central boring	0-12	6.67	1.06	
42-10	Hand augured central boring	12-30	6.78	0.93	
42-10	Hand augured central boring	30-60	7.15	1.35	
43-10	22 increment spatial composite	0-12	7.45	1.18	
43-10	Hand augured central boring	0-12	7.04	0.74	
43-10	Hand augured central boring	12-30	7.35	0.61	
43-10	Hand augured central boring	30-60	7.83	1.13	
44-10	22 increment spatial composite	0-12	7.24	1.80	
44-10	Hand augured central boring	0-12	6.83	0.62	
44-10	Hand augured central boring	12-30	7.40	0.59	
44-10	Hand augured central boring	30-60	7.68	1.56	
45-10	30 increment spatial composite	0-12	7.16	0.95	
45-10	Hand augured central boring	0-12	7.26	0.62	
45-10	Hand augured central boring	12-30	7.57	1.12	
45-10	Hand augured central boring	30-60	7.44	3.84	
46-10	30 increment spatial composite	0-12	7.62	0.95	
46-10	Hand augured central boring	0-12	7.35	1.06	
46-10	Hand augured central boring	12-30	8.00	1.17	
46-10	Hand augured central boring	30-60	8.07	2.47	
47-10	30 increment spatial composite	0-12	7.70	1.09	
47-10	Hand augured central boring	0-12	7.41	1.19	
47-10	Hand augured central boring	12-30	7.97	0.84	

Site	Sample type	Depth (inches)	pH paste	ECe (dS/m)	SAR
47-10	Hand augured central boring	30-60	8.20	1.57	
48-10	30 increment spatial composite	0-12	7.95	0.99	
48-10	Hand augured central boring	0-12	7.76	0.95	
48-10	Hand augured central boring	12-30	8.07	0.73	
48-10	Hand augured central boring, field replicate	12-30	8.02	0.74	
48-10	Hand augured central boring	30-60	8.02	1.47	
49-10	30 increment spatial composite	0-12	7.72	1.10	
49-10	Hand augured central boring	0-12	7.46	1.13	
49-10	Hand augured central boring	12-30	7.81	1.32	
49-10	Hand augured central boring	30-60	8.00	1.55	
50-10	30 increment spatial composite	0-12	7.77	4.95	5.8
50-10	Hand augured central boring	0-12	7.80	0.97	
50-10	Hand augured central boring	12-30	7.94	3.00	
50-10	Hand augured central boring	30-60	7.77	5.12	11.8
51-10	30 increment spatial composite	0-12	7.81	3.39	
51-10	Hand augured central boring	0-12	7.81	2.79	
51-10	Hand augured central boring	12-30	7.93	3.49	
51-10	Hand augured central boring	30-60	7.68	9.99	7.7
52-10	30 increment spatial composite	0-12	7.69	2.24	
52-10	Hand augured central boring	0-12	7.53	1.72	
52-10	Hand augured central boring	12-30	7.69	2.51	
52-10	Hand augured central boring	30-60	7.78	3.71	
53-10	30 increment spatial composite	0-12	7.79	0.94	
53-10	Hand augured central boring	0-12	7.60	0.97	
53-10	Hand augured central boring	12-30	7.94	1.46	
53-10	Hand augured central boring	30-60	7.83	4.49	7.9
54-10	30 increment spatial composite	0-12	7.89	1.53	
54-10	Hand augured central boring	0-12	7.85	0.62	
54-10	Hand augured central boring	12-30	8.05	0.78	
54-10	Hand augured central boring	30-60	8.11	1.38	
55-10	30 increment spatial composite	0-12	7.75	0.87	
55-10	Hand augured central boring	0-12	7.74	0.78	
55-10	Hand augured central boring	12-30	7.89	0.68	
55-10	Hand augured central boring	30-52	7.87	0.61	
56-10	30 increment spatial composite	0-12	7.22	1.37	
56-10	Hand augured central boring	0-12	7.29	1.17	
56-10	Hand augured central boring	12-30	7.43	1.55	
56-10	Hand augured central boring	30-60	7.23	1.85	
57-10	30 increment spatial composite	0-12	7.24	1.31	
57-10	Hand augured central boring	0-12	7.05	0.80	
57-10	Hand augured central boring	12-30	7.68	0.71	
57-10	Hand augured offset boring, paired sample	12-30	7.53	0.78	

Site	Sample type	Depth (inches)	pH paste	ECe (dS/m)	SAR
57-10	Hand augured central boring	30-60	7.25	1.24	
58-10	20 increment spatial composite	0-12	7.59	1.05	
58-10	20 increment spatial composite, field replicate	0-12	7.67	1.14	
58-10	Hand augured central boring	0-12	7.55	1.40	
58-10	Hand augured central boring	12-30	7.62	1.83	
58-10	Hand augured central boring	30-60	7.63	1.71	
59-10	30 increment spatial composite	0-12	7.50	1.16	
59-10	Hand augured central boring	0-12	7.52	1.13	
59-10	Hand augured central boring	12-30	7.72	1.16	
59-10	Hand augured central boring	30-59	7.84	1.78	
60-10	20 increment spatial composite	0-12	7.66	7.83	3.0
60-10	Hand augured central boring	0-12	7.99	1.36	
60-10	Hand augured central boring	12-30	7.85	2.68	
60-10	Hand augured central boring	30-60	8.03	3.06	
61-10	20 increment spatial composite	0-12	7.69	16.0	15.8
61-10	Hand augured central boring	0-12	7.61	6.16	7.2
61-10	Hand augured central boring	12-30	7.54	8.67	9.7
61-10	Hand augured central boring	30-60	7.81	5.28	10.9
62-10	30 increment spatial composite	0-12	7.58	6.25	4.7
62-10	Hand augured central boring	0-12	7.70	4.10	4.5
62-10	Hand augured central boring	12-30	7.78	5.09	4.8
62-10	Hand augured central boring	30-60	8.11	1.60	
63-10	30 increment spatial composite	0-12	7.17	2.04	
63-10	Hand augured central boring	0-12	7.10	3.98	2.5
63-10	Hand augured central boring	12-30	7.36	5.2	6.6
63-10	Hand augured central boring	30-60	7.52	5.95	7.4
64-10	20 increment spatial composite	0-12	7.23	0.83	
64-10	Hand augured central boring	0-12	7.14	1.02	
64-10	Hand augured central boring	12-30	7.45	0.86	
64-10	Hand augured central boring	30-60	7.78	1.13	
N2	20 increment spatial composite, bed shoulders near site 63-10	0-12	6.80	2.88	
N2	20 increment spatial composite, furrow bottom near site 63-10	0-12	7.29	1.97	
N2	Calculated average of beds and furrows	0-12	7.05	2.43	
65-10	30 increment spatial composite	0-12	6.84	0.59	
65-10	Hand augured central boring	0-12	6.81	0.96	
65-10	Hand augured central boring	12-30	7.28	0.96	
65-10	Hand augured central boring	30-60	7.47	1.50	
66-10	30 increment spatial composite	0-12	6.97	0.79	
66-10	Hand augured central boring	0-12	7.36	0.63	
66-10	Hand augured central boring	12-30	7.57	0.75	

Site	Sample type	Depth (inches)	pH paste	ECe (dS/m)	SAR
66-10	Hand augured central boring	30-60	7.65	0.77	
67-10	30 increment spatial composite	0-12	6.97	0.57	
67-10	Hand augured central boring	0-12	6.83	0.56	
67-10	Hand augured central boring	12-30	7.28	0.71	
67-10	Hand augured central boring	30-60	7.41	0.82	
68-10	No lab data, Em survey only				
69-10	20 increment spatial composite	0-12	7.63	0.77	
69-10	Hand augured central boring	0-12	7.56	0.82	
69-10	Hand augured central boring	12-30	7.75	0.87	
69-10	Hand augured central boring	30-60	7.96	2.76	
70-10	20 increment spatial composite	0-12	7.81	1.43	
70-10	Hand augured central boring	0-12	7.66	1.55	
70-10	Hand augured central boring	12-30	7.90	5.40	12.9
70-10	Hand augured central boring	30-48	7.89	5.62	13.9
71-10	20 increment spatial composite	0-12	7.76	1.26	
71-10	Hand augured central boring	0-12	6.71	0.54	
71-10	Hand augured central boring	12-30	6.70	2.65	
71-10	Hand augured central boring	30-60	7.34	2.09	
72-10	Em38 calibration sample 3 increment comp.	0-15	7.81	1.48	
72-10	Em38 calibration sample 3 increment comp	15-30	7.74	6.22	10.2
73-10	20 increment spatial composite	0-12	7.82	0.87	
73-10	Hand augured central boring	0-12	7.73	0.65	
73-10	Hand augured central boring	12-30	7.79	2.30	
73-10	Hand augured central boring	30-60	7.91	1.97	
74-10	20 increment spatial composite, beds	0-12	7.84	1.49	
74-10	20 increment spatial composite, furrows	0-12	7.87	1.58	
74-10	Hand augured central boring	0-12	7.69	1.94	
74-10	Hand augured central boring	12-30	7.85	2.29	
74-10	Hand augured central boring	30-60	7.92	2.41	
75-10	30 increment spatial composite	0-12	7.73	3.13	
75-10	Hand augured central boring	0-12	7.72	3.04	
75-10	Hand augured central boring	12-30	7.72	9.89	9.3
75-10	Hand augured central boring	30-60	7.69	7.64	9.1
76-10	30 increment spatial composite	0-12	7.64	11.3	11.8
76-10	Hand augured central boring	0-12	7.43	9.23	8.4
76-10	Hand augured central boring	12-30	7.77	5.02	12.8
76-10	Hand augured central boring	30-60	8.12	2.19	
76-10	Em38 calibration sample, 6 increment comp.	0-15	7.2	15.5	12.1
76-10	Em38 calibration sample, 5 increment comp.	15-30	7.92	1.80	
77-10	Em38 calibration sample, 5 increment comp	0-15	7.39	0.93	
77-10	Em38 calibration sample, 5 increment comp	15-30	7.05	1.26	
78-10	No data				

Site	Sample type	Depth (inches)	pH paste	ECe (dS/m)	SAR
79-10	22 increment spatial composite	0-12	8.07	7.13	17.5
79-10	Hand augured central boring	0-12	7.90	8.20	21.0
79-10	Hand augured central boring	12-30	7.95	6.28	11.5
79-10	Hand augured central boring	30-60	8.25	2.46	

1

2

1 **Appendix B: Soil logs from 2010 baseline soil sampling event**

2  
3  
4  
5  
6  
7  
8  
9  
10  
11  
12  
13  
14  
15  
16  
17  
18  
19  
20  
21  
22  
23  
24  
25  
26  
27  
28  
29  
30  
31  
32  
33  
34  
35  
36  
37  
38  
39  
40  
41  
42



1 **Appendix C: EM38 Soil Bulk Electrical Conductivity Data Summary**

Site	Inverted profiles (%)	EMh average (mS/m)	EMh 95% confidence range	EMv average (mS/m)	EMv 95 % confidence range
1-10	7.1	27.3	23.2-31.4	43.3	41.1- 45.5
2-10	51.5	23.2	17.6 – 28.8	23.7	18.8 - 28.6
3-10	79.2	42.1	33.9 – 50.4	36.8	29.6 - 44.0
4-10	14.3	22.5	19.4 – 25.6	25.0	22.0 - 28.0
5-10	30.0	53.9	48.7 – 59.1	51.4	46.3 – 56.5
6-10	53.8	9.9	8.9 10.9	9.9	9.0 – 10.8
7-10	15.4	21.2	18.3 – 24.1	25.1	22.0 – 28.2
8-10	00	22.2	20.6 – 23.8	25.5	23.7 – 27.3
9-10	35.7	17.0	16.3 – 17.7	17.6	16.3 – 18.9
10-10	11.1	16.1	15.2 – 17.0	16.8	15.8 – 17.8
11-10	00	30.4	27.5 – 33.3	37.2	33.8 – 40.6
12-10	5.0	19.4	15.2 – 23.6	24.5	19.9 – 29.1
13-10	77.2	41.5	36.7 – 46.3	39.0	33.7 - 44.3
14-10	17.6	29.1	26.8 – 31.4	33.3	30.6 – 36.0
15-10	4.3	61.1	55.8 – 66.4	72.8	66.5 – 79.1
16-10	15.8	28.1	25.2 – 31.0	33.4	29.5 – 37.3
17-10	72.2	38.9	33.8 – 44.0	35.2	31.4 – 39.0
18-10	00	48.4	42.1 – 54.7	61.4	53.4 – 69.4
19-10	11.1	30.4	26.9 – 33.9	35.4	31.1 – 39.7
20-10	17.6	49.6	44.2 – 55.0	59.9	51.9 – 67.9
21-10	5.6	19.6	15.4 – 23.8	32.7	26.8 – 38.6
22-10	00	7.1	6.7 – 7.5	17.4	16.8 – 18.0
23-10	13.3	5.0	4.4 – 5.6	6.3	5.5 – 7.1
24-10	12.5	8.8	7.7 – 9.9	11.9	10.8 – 13.0
25-10	00	41.2	37.7 – 44.7	67.6	62.6 – 72.6
26-10	00	27.3	24.0 – 30.5	47.5	41.4 – 53.6
27-10	00	51.2	48.7 – 53.7	77.1	72.8 – 81.4
28-10	12.5	37.2	35.4 – 39.0	56.1	51.8 – 61.4
29-10	33.3	29.3	26.9 – 31.7	48.3	45.0 – 51.6
30-10	20.0	36.2	33.9 – 38.5	44.4	41.3 – 47.5
31-10	60.0	33.5	30.9 – 36.1	33.2	30.0 – 36.4
32-10	10.0	70.3	66.1 – 74.5	99.2	93.7 – 104.7
33-10	3.3	39.7	37.0 – 42.4	57.6	53.7 – 61.5
34-10	5.0	90.7	88.3 – 93.1	112.8	104.1–121.5
35-10	00	33.5	31.5 – 35.5	43.1	40.6 – 45.6
36-10	00	54.0	51.9 – 56.1	68.3	66.9 – 70.7
37-10	00	40.1	34.8 – 45.4	66.1	58.9 – 73.3

Site	Inverted profiles (%)	EMh average (mS/m)	EMh 95% confidence range	EMv average (mS/m)	EMv 95 % confidence range
38-10	00	53.7	49.7 – 57.7	81.9	76.5 – 87.3
39-10	00	49.8	44.4 – 55.2	69.8	65.8 – 73.8
40-10	00	59.7	54.9 – 64.5	91.1	82.1 – 100.1
41-10	4.8	49.8	46.5 – 53.1	86.8	77.8 – 95.8
42-10	00	39.9	37.1 – 42.7	67.3	60.7 – 73.9
43-10	00	49.0	45.9 – 52.1	74.7	67.7 – 81.7
44-10	00	42.9	39.1 – 46.7	66.9	59.7 – 74.1
45-10	00	57.5	46.9 – 68.1	66.7	53.7 – 79.7
46-10	00	68.1	64.5 – 71.7	90.2	85.9 – 94.5
47-10	00	60.3	57.5 – 63.1	84.9	82.4 – 87.4
48-10	00	43.1	41.2 – 45.0	61.8	59.1 – 64.5
49-10	00	62.0	59.8 – 64.2	91.7	89.6 – 93.8
50-10	16.7	88.3	79.4 – 97.2	136.2	112.4-160.0
51-10	00	122.5	111.8-133.2	162.2	149.7-174.7
52-10	00	91.4	87.3 – 95.5	125.7	119.4–132.0.
53-10	00	58.4	55.5 – 61.3	95.2	89.8 - 100.6
54-10	00	49.1	47.3 – 50.9	78.9	71.4 – 86.4
55-10	00	25.4	23.2 – 27.6	36.5	33.4 – 39.6
56-10	38.1	38.4	33.2 – 43.6	39.1	34.6 – 43.6
57-10	5.0	34.5	31.9 – 37.1	42.3	39.6 – 49.0
58-10	00	51.5	48.7 – 54.3	68.3	65.1 – 71.5
59-10	00	45.2	43.1 – 47.3	60.4	55.9 – 64.9
60-10	5.9	42.1	39.1 – 45.1	49.9	46.4 – 53.4
61-10	15.8	107.2	99.6-114.8	130.2	121.7-138.7
62-10	00	42.7	40.4 – 45.0	53.5	50.3 – 56.7
63-10	00	79.2	74.4 – 84.0	101.7	94.7-108.7
64-10	00	64.8	62.2 – 67.4	81.7	78.9 - 84.5
65-10	00	51.4	48.6 – 54.2	79.9	76.0 – 83.8
66-10	00	34.1	30.5 – 37.7	49.8	45.4 – 54.2
67-10	00	40.1	38.5 – 41.7	61.8	59.0 – 64.6
68-10	00	31.4	23.2 – 39.6	51.9	38.9 – 64.9
69-10	00	64.8	62.1 – 67.5	80.7	77.7 – 83.7
70-10	00	98.8	90.5 – 107.1	135.3	120.3-150.3
71-10	8.7	56.7	55.1 – 58.3	78.2	74.4 – 82.0
72-10	58.3	150.4	132.0-168.8	177.2	157.7-196.7
73-10	5.3	120.2	110.0-130.4	169.5	157.0-182.0
74-10	00	62.1	59.5 – 64.7	83.4	79.9 – 86.9
75-10	00	63.1	53.6 – 72.6	98.1	83.9-112.3
76-10	75.0	52.6	48.1 – 57.1	43.2	38.0 – 48.4
77-10	00	38.6	34.1 – 43.1	67.8	60.1 – 75.5
78-10	No data				

<b>Site</b>	<b>Inverted profiles (%)</b>	<b>EMh average (mS/m)</b>	<b>EMh 95% confidence range</b>	<b>EMv average (mS/m)</b>	<b>EMv 95 % confidence range</b>
79-10	50.0	91.5	82.5-100.5	91.6	87.6-95.6

1 Note: corrected to 25 degrees Celcius

2

3

4

1 **Appendix D: Soil drainage data**

Site	Date	Depth to mottling (inches)	Depth to capillary fringe (inches)	Depth to groundwater (inches)	Type of salinity profile
1-10	2-26-10	20	Over 60	Over 60	Uniform
2-10	3-1-10	Over 60	60	62	Inverted
3-10	3-1-10	Over 60	54	58	Inverted
4-10	3-2-10	52	Over 60	Over60	Regular
5-10	3-2-10	30	Over 60	Over 60	Inverted
6-10	3-2-10	28	Over 60	Over 60	Uniform
7-10	3-2-10	17	Over 60	Over 60	Regular
8-10	3-2-10	28	46 inches	Over 60	Uniform
9-10	3-2-10	57	Over 60	Over 60	Uniform
10-10	3-2-10	34	Over 60	Over 60	Inverted
11-10	3-9-10	26	Over 60	Over 60	Regular
12-10	3-9-10	41	Over 60	Over 60	Inverted
13-10	3-9-10	52	Over 60	Over 60	Inverted
14-10	3-9-10	58	Over 60	Over 60	Regular
15-10	3-9-10	28	Over 60	Over 60	Regular
16-10	3-9-10	54	Over 60	Over 60	Regular
17-10	3-11-10	51	90	100	Inverted
18-10	3-11-10	14	Over 60	Over 60	Regular
19-10	3-11-10	18	Over 60	Over 60	Regular
20-10	3-11-10	18	Over 60	Over 60	Regular
21-10	3-11-10	17	Over 60	Over 60	Uniform
22-10	3-16-10	28	Over 60	Over 60	Uniform
23-10	3-16-10	Over 60	Over 60	Over 60	Uniform
24-10	3-16-10	30	Over 60	Over 60	Uniform
25-10	3-17-10	Over 60	Over 60	Over 60	Uniform
26-10	3-17-10	18	Over 60	Over 60	Uniform
27-10	3-17-10	14	Over 60	Over 60	Regular
28-10	3-17-10	19	Over 60	Over 60	Uniform
29-10	3-18-10	Over 60	Over 60	Over 60	Inverted
30-10	3-18-10	Over 60	Over 60	Over 60	Uniform
31-10	3-18-10	Over 60	Over 60	Over 60	Inverted
32-10	3-18-10	Over 60	Over 60	Over 60	Regular
33-10	3-18-10	Over 60	Over 60	Over 60	Regular
34-10	3-23-10	Over 60	Over 60	Over 60	Uniform
35-10	3-23-10	50	Over 60	Over 60	Uniform
36-10	3-23-10	48	Over 60	Over 60	Inverted
37-10	3-23-10	55	55	Over 60	Uniform

Site	Date	Depth to mottling (inches)	Depth to capillary fringe (inches)	Depth to groundwater (inches)	Type of salinity profile
38-10	3-23-10	44	60	Over 64	Uniform
39-10	3-23-10	28	Over 60	Over 60	Uniform
40-10	3-24-10	55	55	Over 60	Regular
41-10	3-24-10	42	30	55	Uniform
42-10	3-24-10	45	54	84 estimated	Uniform
43-10	3-24-10	Over 60	50	54	Uniform
44-10	3-24-10	22	62	Over 62	Uniform
45-10	3-30-10	34	48	56	Regular
46-10	3-30-10	20	40	55	Regular
47-10	3-30-10	54	46	54	Uniform
48-10	3-30-10	45	50	60	Regular
49-10	3-30-10	27	51	72 estimated	Regular
50-10	3-30-10	30	24	54	Inverted
51-10	3-31-10	39	24	49	Regular
52-10	3-31-10	31	31	45	Regular
53-10	3-31-10	27	45	Over 64	Regular
54-10	3-31-10	47	47	55	Uniform
55-10	3-31-10	48	47	47	Uniform
56-10	4-6-10	12	Over 60	Over 60	Regular
57-10	4-6-10	Over 60	Over 60	Over 60	Uniform
58-10	4-6-10	38	Over 60	Over 60	Regular
59-10	4-6-10	12	40	Over 60	Regular
60-10	4-8-10	43	Over 60	Over 60	Inverted
61-10	4-8-10	Over 60	30	37	Inverted
62-10	4-8-10	52	52	59	Inverted
63-10	4-8-10	49	30	51	Regular
64-10	4-8-10	50	24	43	Uniform
65-10	4-15-10	32	95	107	Regular
66-10	4-15-10	25	120	Over 124	Uniform
67-10	4-15-10	64	94	99	Regular
68-10	4-19-10	18	33	Over 48	Not sampled
69-10	4-19-10	33	30	47	Regular
70-10	4-19-10	29	12	26	Regular
71-10	4-26-10	49	Over 60	Over 60	Regular
72-10	4-26-10	Over 30	Over 30	Over 30	Regular
73-10	4-26-10	40	Over 60	Over 60	Regular
74-10	4-27-10	44	30	64	Regular
75-10	4-27-10	49	49	64	Regular
76-10	4-27-10	25	Over 63	Over 63	Inverted
77-10	4-30-10	Over 30	Over 30	Over 30	Regular
78-10	5-6-10	Over 36	Over 36	Over 36	Not sampled

<b>Site</b>	<b>Date</b>	<b>Depth to mottling (inches)</b>	<b>Depth to capillary fringe (inches)</b>	<b>Depth to groundwater (inches)</b>	<b>Type of salinity profile</b>
79-10	5-6-10	Over 63	12	29	Inverted

1  
2  
3

1 **Appendix E: Maps showing Soil Boring Locations**

2

3

4

5

6

7

8

9

10

11

12

13

14

15

16

17

18

19

20

21

22

23

24

25

26

27

28

29

30

31

32

33

34

35

36

37

38

39

40

41

42

43

44

Reports  
Appendix

1 **Appendix F: List of Abbreviations and Acronyms used on soil logs**

2

3 **Soil colors**

4 Grbr = grayish brown

5 Brgr = brownish gray

6 Dk = dark

7 Gr = gray

8 Br = brown

9 Pbrn = pale brown

10 Olbr = olive brown

11 Yel = yellow

12

13 **Soil texture**

14 F = fine

15 Co =coarse

16 Sl=sandy loam

17 Sil =silt loam

18 Ltl = light loam

19 L = loam

20 S =sand

21 Ls = loamy sand

22 Cos = coarse sand

23 C = clay

24 Cl = clay loam

25 Scl = sandy clay loam

26 Sicl = silty clay loam

27 Sic = silty clay

28 Lfs= loamy fine sand

29 Vfsl = very fine sandy loam

30 Fsl = fine sandy loam

31 Gr = gravelly

32 V =very

33 Lt = light

34 H = heavy

35

36 **Soil structure**

37 St =strong

38 M = moderate

39 W =weak

40 Sg = single grained

41 Bl = blocky



- 1 Med = medium
- 2 Sab =subangular blocky
- 3
- 4 **Other abbreviations**
- 5 Sat = saturated
- 6 HCL = hydrochloric acid (dilute)
- 7 Obs well = observation well
- 8 Rep = field replicate soil sample
- 9 Paired = paired soil samples
- 10 X = multi increment composite soil sample
- 11 30X = 30 increment composite soil sample
- 12 Cal= calibration sample for EM38 interpretation
- 13 Cap- capillary fringe
- 14 Fe = iron
- 15 SAR = sodium adsorption ratio
- 16 ECe = electrical conductivity of the saturation extract
- 17 Wt = water table
- 18 Slt = slight
- 19 Cal = calibration
- 20 EM38 = Instrument that measures electrical conductivity of the soil.
- 21 EMh= EM38 reading in the horizontal position
- 22 EMv = EM38 reading in the vertical position
- 23 Ne = not evaluated
- 24 Ns = not sampled
- 25 Tcor = Temperature corrected to 25C
- 26 Avg = average
- 27 In = inches
- 28 Ft = feet
- 29 Gyp = gypsum
- 30 pHp = soil reaction of the soil saturated paste
- 31 SP = saturation percentage
- 32 NRCS = Natural Resources Conservation Service
- 33 PSA = particle size analysis
- 34 BGS = below ground surface
- 35 TOC = top of casing
- 36 RPD = relative percent difference
- 37

# 1 **19.0 1D Inundation Mapping**

## 2 **19.1 Introduction**

3 This report addresses inundation mapping conducted to provide an initial estimate of  
4 existing inundation depths along the San Joaquin River.

## 5 **19.2 Methods**

6 The SJRRP conducted inundation mapping in Fall 2010 based on one-dimensional  
7 hydraulic modeling in HEC-RAS. The existing conditions model titled SJRRP07 was  
8 used in order to represent the existing levels of floodplain available along the San Joaquin  
9 River. The HEC-RAS hydraulic model is documented in Mussetter, 2008. The SJRRP  
10 modeled steady-state releases from Friant Dam of 50, 100, 200, 400, 600, 800, 1000,  
11 1250, 1500, 1750, 2000, 2250, 2500, 2750, 3000, 3500, 4000, and 4500 cfs. Local flows  
12 at downstream locations include flow loss assumptions and assume 300 cfs of additional  
13 flow in Reach 3 for San Luis Canal Company deliveries. Table below shows the flow  
14 assumptions made. Analysis does not include Reach 4B1, as this reach does not allow  
15 passage of Interim Flows and this includes minimal floodplain habitat. This initial report  
16 also does not include Reach 4B2 or the Mariposa Bypass. Mussetter used equal  
17 exceedance frequencies to historical releases of these Friant flows to determine  
18 downstream tributary inflow at Mud and Salt Sloughs as well as Bear Creek.  
19

20 The SJRRP interpolated water surface elevations at each HEC-RAS cross-section  
21 between cross-sections to develop a 3D surface of elevations. The SJRRP then compared  
22 this surface to 3D terrain surfaces, which the SJRRP developed from a combination of  
23 1998 Ayers / COE photogrammetry and 2008 LIDAR. Mussetter used these same  
24 datasets to develop the HEC-RAS cross-sectional geometry. The difference between  
25 water surface elevation and terrain elevation created a depth map. The analysis calculated  
26 the numbers of acres inundated at each depth range at all the modeled Friant release  
27 flows. The SJRRP separated inundation areas into in-channel and overbank acreages,  
28 based on vegetation that marks the edge of the low-flow channel.  
29

30 Quality control of results included editing to better represent existing inundated areas that  
31 could provide habitat along the San Joaquin River. Areas removed include off-channel  
32 pools that show up as an artifact of the 1D hydraulic modeling, floodplain associated with  
33 tributary watersheds, gravel pits, canals, and flooded farmland. In many of the reaches,  
34 flows less than 4500 cfs overtop levees. Floodplain inundation depths and areas were not  
35 developed at flows past those that overtop levees, as agricultural land should not be  
36 considered existing floodplain habitat. Thus, results do not go above channel capacity.

- 1 Inundation maps also show no results outside of levees in many areas due to this
- 2 decision.

**Table 19-1: Flow Assumptions in Downstream Reaches for each Friant Release Profile**

Subreach	Location	Station (ft)	Release Profile (cfs)																	
			50	100	200	400	600	800	1000	1250	1500	1750	2000	2250	2500	2750	3000	3500	4000	4500
			Model Discharge (cfs)																	
1A	Friant Release	785457	50	100	200	400	600	800	1000	1250	1500	1750	2000	2250	2500	2750	3000	3500	4000	4500
1A	Highway 41	720730	34	68	151	351	551	751	951	1201	1451	1701	1951	2201	2451	2701	2951	3451	3951	4451
1A	Highway 99	658650	19	38	104	304	504	704	904	1154	1404	1654	1904	2154	2404	2654	2904	3404	3904	4404
1B	Highway 145	610195	7	14	68	268	468	668	868	1118	1368	1618	1868	2118	2368	2618	2868	3368	3868	4368
2A	Gravelly Ford	581185	0	0	46	246	446	646	846	1096	1346	1596	1846	2096	2346	2596	2846	3346	3846	4346
2A	U/S end LB Levee	559400	0	0	31	212	407	603	800	1046	1294	1541	1789	2037	2286	2534	2782	3280	3777	4275
2B	Bifurcation Structure	515250	0	0	0	145	328	516	706	947	1188	1431	1675	1919	2164	2409	2654	3146	3639	4132
3	Mendota Dam	455735	300	300	300	445	628	816	1006	1247	1488	1731	1975	2219	2464	2709	2954	3446	3939	4432
4A	Sack Dam	337385	0	0	0	145	328	516	706	947	1188	1431	1675	1919	2164	2409	2654	3146	3639	4132
4B1	Sand Slough CS	265545	0	0	0	0	0	0	0	0	0	0	0	0	0	0	0	0	0	0
4B2	Mariposa Bypass	154150	0	0	0	0	0	0	0	0	0	0	0	0	0	0	0	0	0	0
5	Eastside Bypass	95700	0	2	54	241	446	650	854	1106	1362	1617	1875	2141	2405	2666	2925	3437	3956	4498
5	Salt Slough	59245	71	163	328	555	775	990	1202	1463	1729	2000	2277	2566	2852	3129	3403	3935	4476	5052
5	Mud Slough	17180	88	228	478	743	978	1203	1424	1694	1973	2254	2543	2849	3149	3438	3723	4273	4835	5441
5	Merced River	17181	134	408	900	1416	1760	2084	2399	2779	3201	3620	4081	4635	5147	5546	5929	6615	7339	8184

Chowchilla Bypass	Bifurcation Structure	--	0	0	0	0	0	0	0	0	0	0	0	0	0	0	0	0	0	0
Eastside Bypass	SJR CS	--	0	0	0	145	328	516	706	947	1188	1431	1675	1919	2164	2409	2654	3146	3639	4132
Eastside Bypass	Mariposa Bypass	--	0	0	0	145	328	516	706	947	1188	1431	1675	1919	2164	2409	2654	3146	3639	4132
Eastside Bypass	Bear Creek	--	0	2	54	241	446	650	854	1106	1362	1617	1875	2141	2405	2666	2925	3437	3956	4498

Bear Creek contribution	0	2	54	96	118	134	148	159	173	186	201	222	241	257	271	291	317	366
Salt Slough contribution	71	161	274	314	329	340	348	357	368	383	401	426	447	463	478	498	520	554
Mud Slough contribution	16	65	150	187	203	213	222	232	244	254	266	283	297	308	320	338	359	390
Merced River contribution	47	180	422	673	782	881	975	1085	1229	1366	1538	1786	1998	2109	2205	2343	2504	2743

## 19.3 Results

Table and Table below shows results starting at 400 cfs. Due to loss assumptions, lower flows do not make it through all the reaches. 9,800 acres of area inundates at a Friant release of 4500 cfs. Reach 5 and the Eastside Bypass contain the most inundated area, with large amounts also in Reach 1A, Reach 3, and Reach 1B (Figure). Most area inundates to greater than 5 feet, with considerable areas inundated between 1 and 2 feet at all Friant release flows (Figure). Figures 3 and 4 show the area inundated within the vegetation line that marks the edge of the low-flow channel.

Figure and Figure show inundated overbank area. Reach 2B has only minimal overbank as most of the Reach currently contains backwater from Mendota Pool, considered in channel. This analysis considered in channel area within the levees in the Eastside Bypass, and area outside the levees outside this analysis scope. This explains why Figure does not include the Eastside Bypass.

Figure shows 2693 acres inundated between 1 and 3 feet in depth in the various reaches at a 4500 cfs release of flow from Friant Dam. As shown in Figure, 760 acres inundate with San Joaquin River water between 0.5 and 1 foot of depth at a 4500 cfs release of flow from Friant Dam.

**Table 19-2: Total Inundated Area by Reach (All Depths)**

Friant Flow (cfs)	1A (acres)	1B (acres)	2A (acres)	2B (acres)	3 (acres)	4A (acres)	ESB (acres)	5 (acres)	Total Area (acres)
400	510	223	271	250	354	192	339	435	2576
800	611	320	376	310	417	247	704	612	3597
1000	650	402	410	336	461	273	799	709	4039
1500	749	515	485	390	626	332	1036	930	5063
2000	878	566	550	424	773	400	1259	1208	6057
2500	972	663	601	424	886	467	1411	1550	6975
3000	1043	745	650	424	948	467	1655	1942	7874
4000	1211	875	730	424	1026	467	2026	2531	9291
4500	1273	923	767	424	1063	467	2146	2780	9843

**Table 19-3: Total Inundated Area by Depth in Feet (All Reaches)**

Friant Flow (cfs)	Area 0.5-1 feet deep (acres)	Area 0-0.5 feet deep (acres)	Area 1-2 feet deep (acres)	Area 2-3 feet deep (acres)	Area 3-4 feet deep (acres)	Area 4-5 feet deep (acres)	Area >5 feet deep (acres)	Total (acres)
400	239	214	462	391	382	306	582	2576
800	352	354	588	502	422	361	1017	3597
1000	412	353	686	548	466	358	1216	4039
1500	421	437	851	715	568	464	1606	5063
2000	516	459	926	906	687	525	2037	6057
2500	552	508	1047	958	848	640	2422	6975
3000	620	595	1187	991	962	757	2762	7874
4000	740	669	1344	1170	1019	896	3454	9291
4500	760	633	1446	1247	1038	957	3762	9843

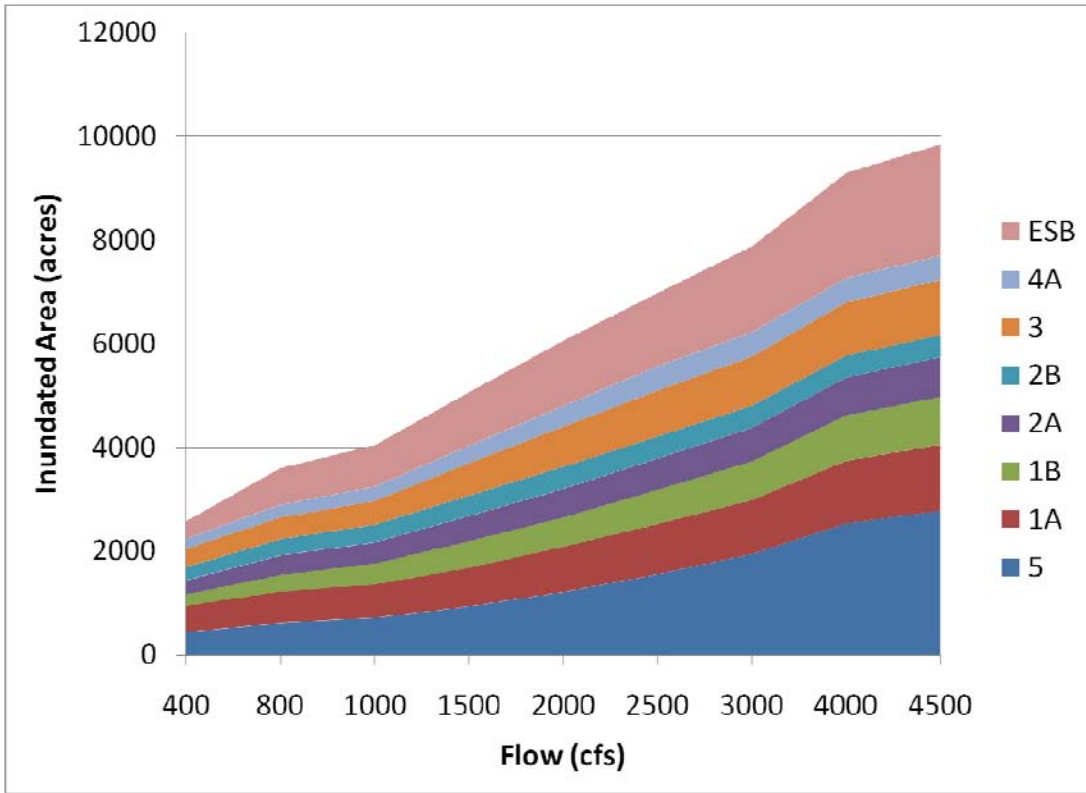

29  
30

Figure 19-1: Total Inundated Area by Reach

31

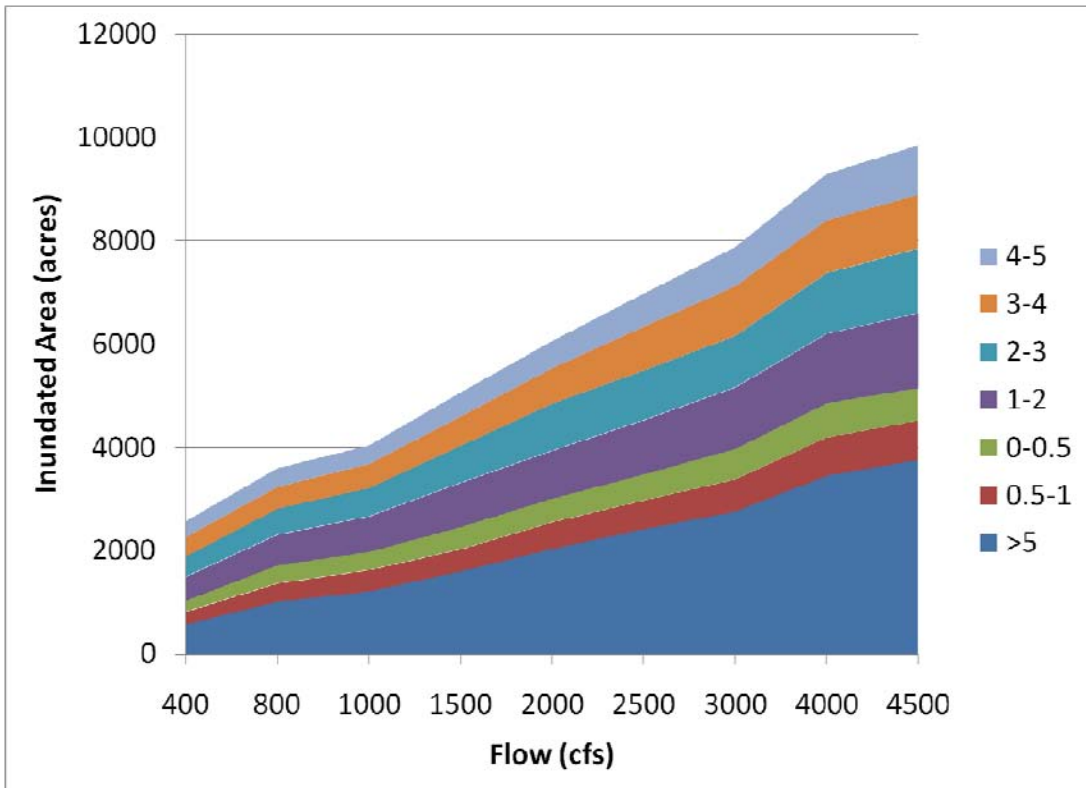

32

33 Figure 19-2: Total Inundated Area by Depth in feet

34

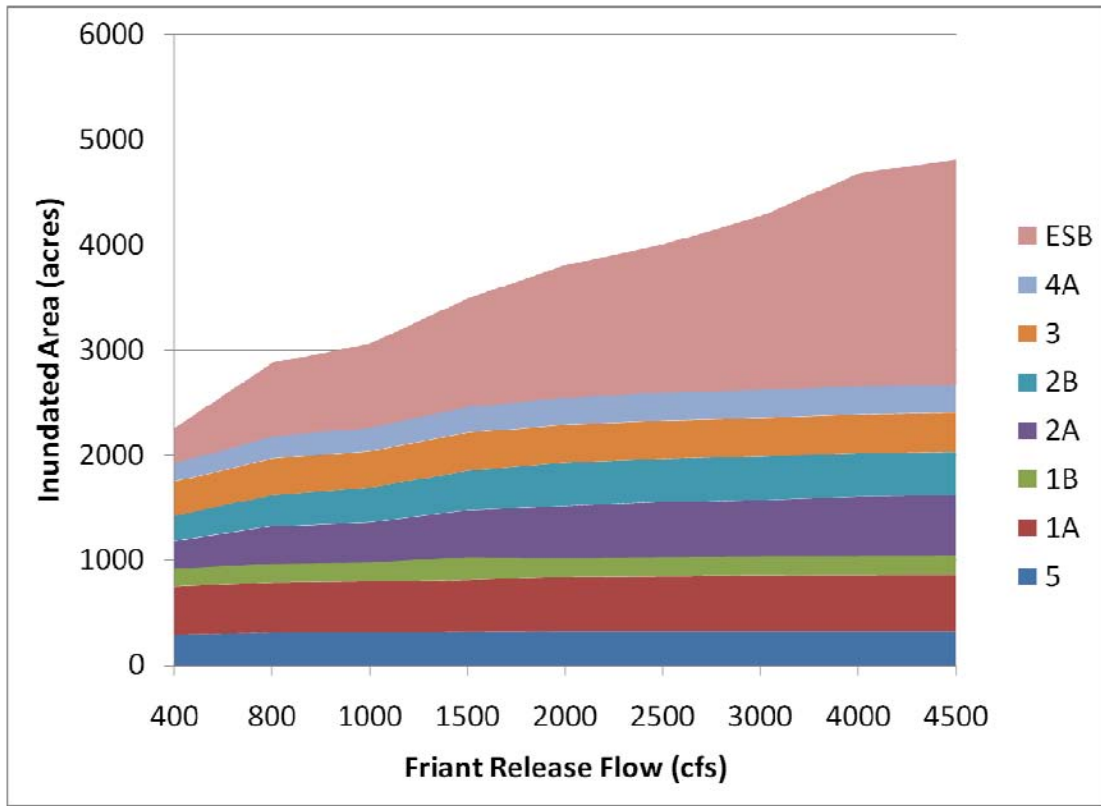

35 Figure 19-3: In Channel Inundated Area by Reach

36

37

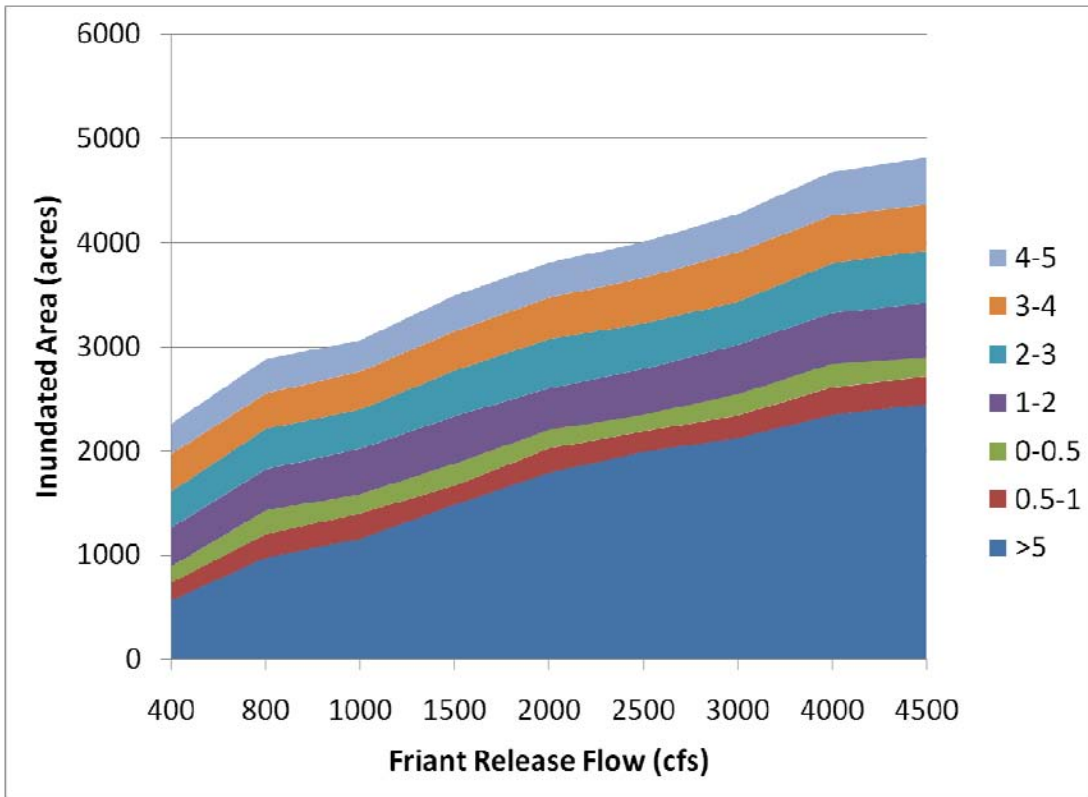

38  
39

Figure 19-4: In Channel Inundated Area by Depth in feet

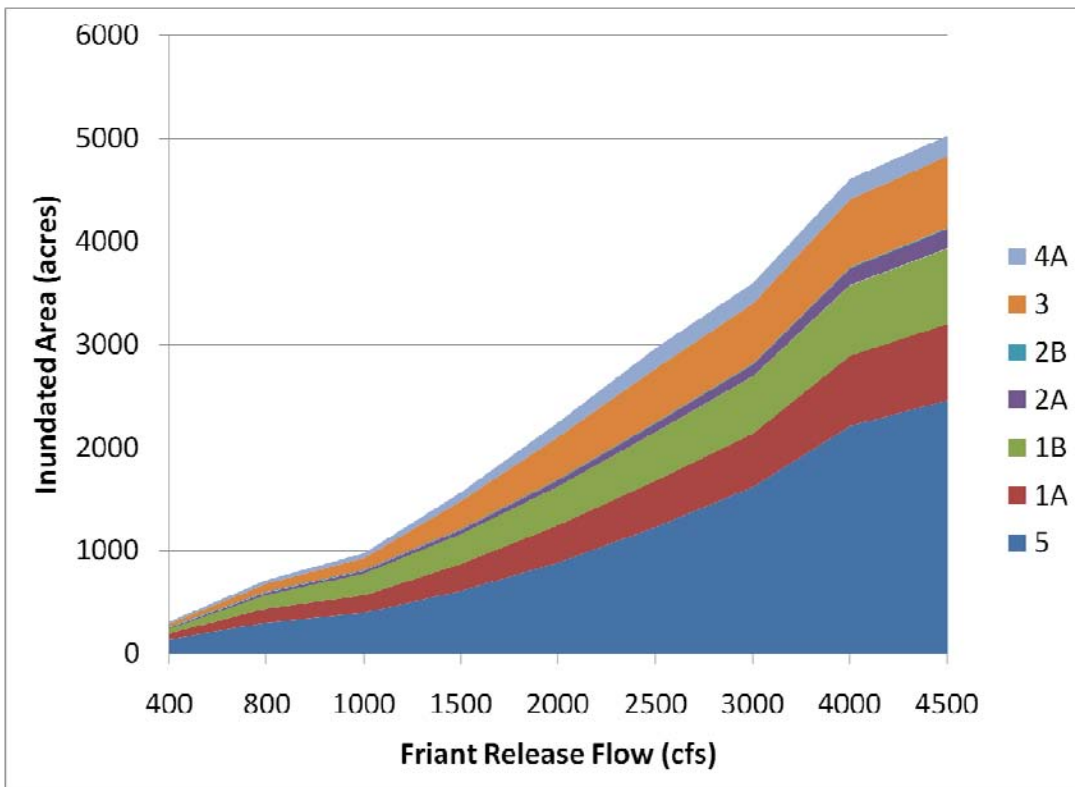

40  
41

Figure 19-5: Overbank Inundated Area by Reach



42  
43

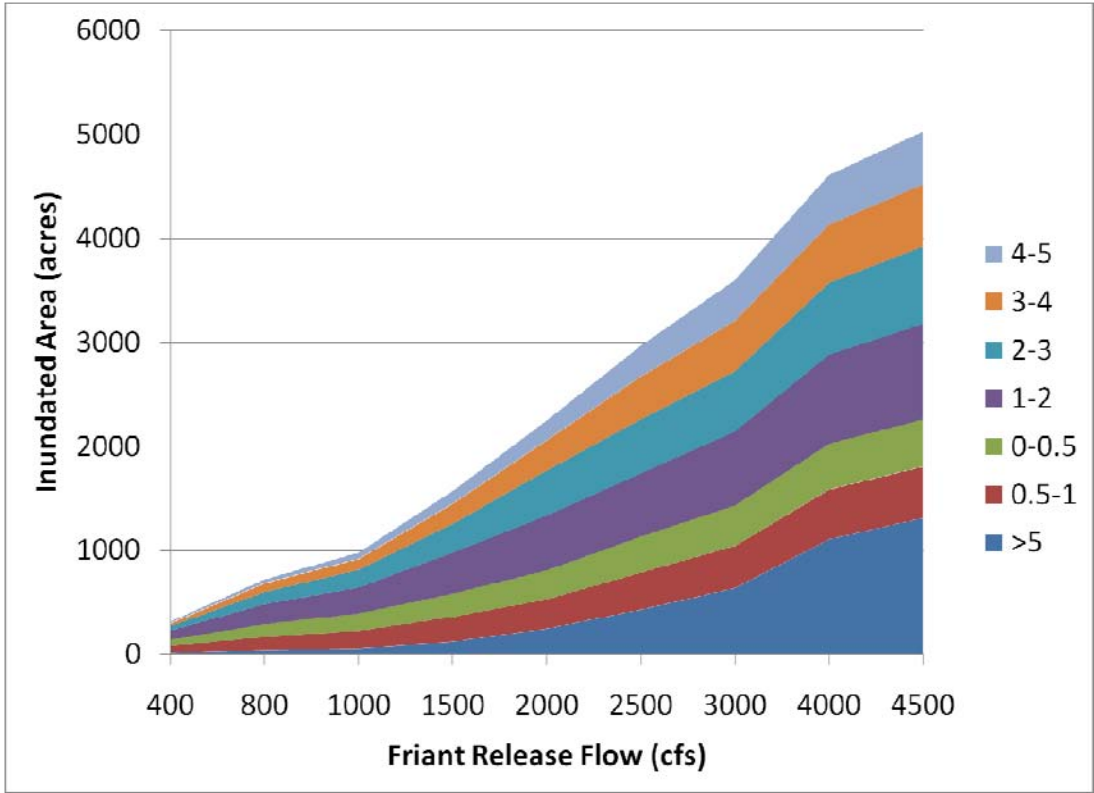

44  
45

Figure 19-6: Overbank Inundated Area by Depth in Feet

46

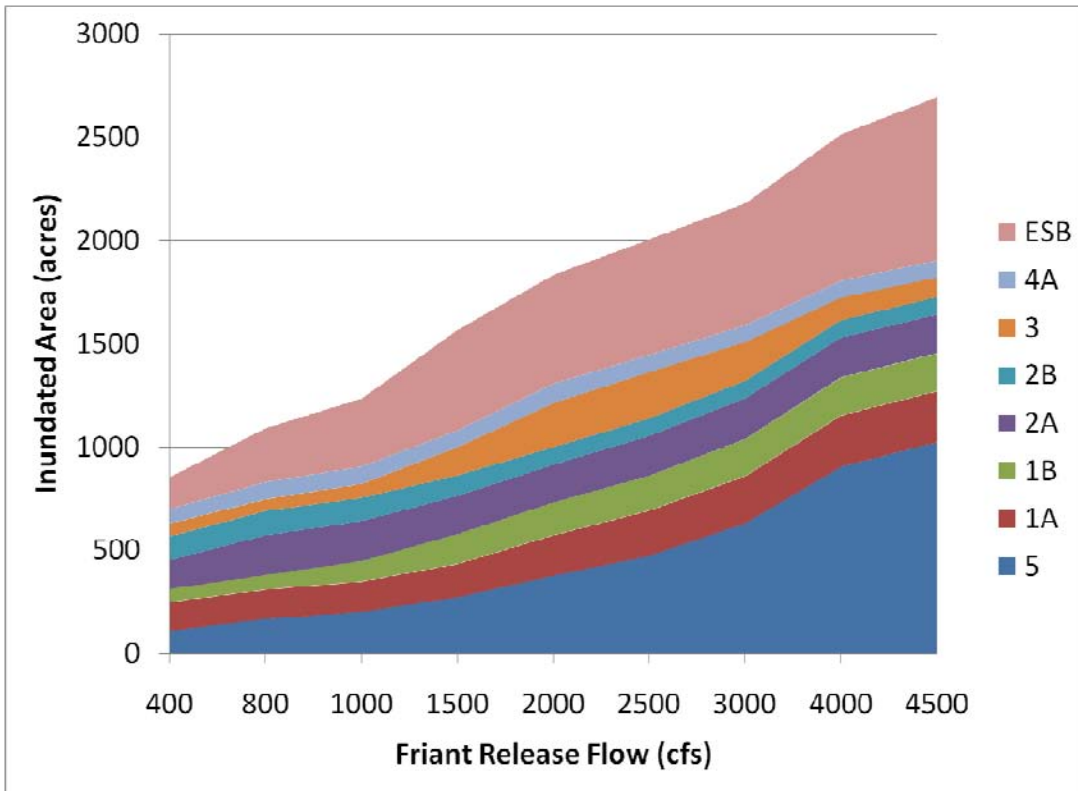

47  
48

Figure 19-7: Total Inundated Area from 1 to 3 foot deep, by Reach

49

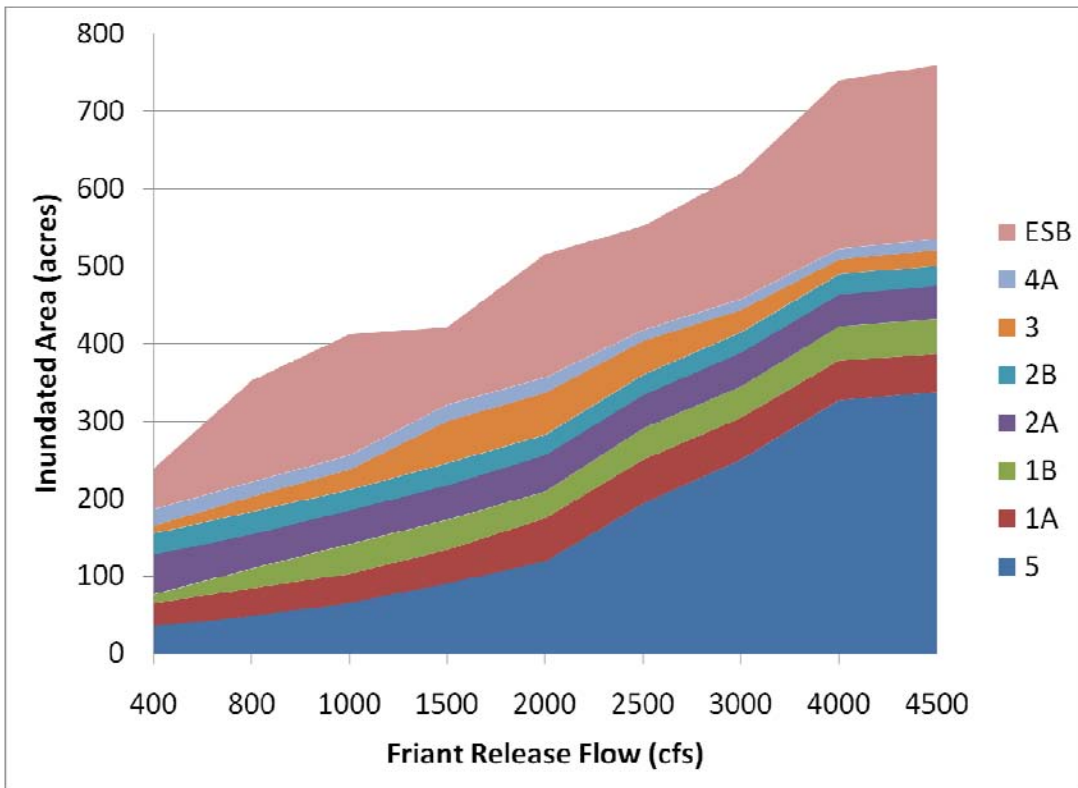

50  
51

Figure 19-8: Total Inundated Area from 0.5 to 1 foot deep, by Reach

52 **19.4 Discussion**

53 Limitations of this analysis include:

- 54 • One dimensional hydraulic modeling means results assume a constant river water  
55 surface elevation at each cross-section and a linear interpolation between cross  
56 sections. The analysis does not include hydraulic boundaries, jumps, or  
57 bathymetry in between cross-sections that could influence the water surface  
58 elevation.
  
- 59 • The analysis assumes steady-state Friant releases. Results do not include  
60 inundated acres as a result of hydrographs with changing flow releases.
  
- 61 • Results attempt to remove obvious non-habitat areas such as agricultural lands or  
62 gravel pits, but this analysis includes all other areas within levees. This includes  
63 sand point bars, invasive vegetation, etc.
  
- 64 • The extrapolation of one dimensional modeling over a three dimensional terrain  
65 surface ignores barriers to flow that could limit inundation in side channels at  
66 lower flows.
  
- 67 • The hydraulic model pieced in 2008 LiDAR for overbank on top of existing 1998  
68 Ayers bathymetry on a cross-section by cross-section basis. The developers of the  
69 model did not develop a terrain surface and no known documentation of this  
70 splicing line exists. Terrain developed for this inundation mapping analysis  
71 attempted to mimic this approach to ensure the same baseline terrain as used in  
72 the model for comparison, but inconsistencies may exist. These may result in  
73 slight inaccuracies in acres of inundation at higher flows. These unbiased  
74 inconsistencies should result in no net over- or under-estimation of inundated  
75 acres.

76 **19.5 Conclusions and Recommendations**

77 Large amounts of floodplain habitat exist in Reaches 5 and the Eastside Bypass.  
78 Approximately 9,800 acres will be inundated at 4500 cfs, without any channel  
79 improvements made in Reaches 2B and 4B.

80 **19.6 References**

81 Mussetter Engineering, Inc., 2008 San Joaquin HEC-RAS Model Documentation  
82 Technical Memorandum prepared for California Dept. of Water Resources, Fresno,  
83 California, June 2.

# San Joaquin River Restoration Program Fish Passage Evaluation

---

## Task 1

### Draft Technical Memorandum

Identification, Data Collection, and Initial Evaluation of  
Potential Fish Passage Barriers

**February 2011**

*[This page has been intentionally left blank]*

State of California  
The Resources Agency  
DEPARTMENT OF WATER RESOURCES  
Division of Integrated Regional Water Management  
South Central Region Office

**San Joaquin River Restoration Program  
Fish Passage Evaluation**

**Task 1**

**DRAFT**

**February 28, 2011**

This report was prepared for the San Joaquin River Restoration Program  
under the direction of

Paul Romero..... Chief, River Restoration and Environmental Compliance Branch  
S. Greg Farley ..... Senior Engineer

by

Amanda Peisch-Derby .....Engineer

with assistance from

Abimael Leon-Cardona.....Environmental Scientist  
Byron Willems .....Engineer  
Josh Bannister .....Engineer  
Kandasamy Naventhan .....Engineer  
Eric Guzman .....Environmental Scientist (DFG)

*[This page has been intentionally left blank]*

## Table of Contents

INTRODUCTION .....	1
IDENTIFICATION OF POTENTIAL FISH PASSAGE BARRIERS .....	3
Existing List of Potential Barriers .....	3
Identification of Additional Structures.....	4
Selection of Structures to be Evaluated.....	5
INITIAL EVALUATION CRITERIA .....	11
Initial Evaluation Tool .....	11
Initial Evaluation Categories.....	12
FIRST PASS DATA COLLECTION.....	16
RESULTS OF FIRST PASS EVALUATION.....	17
ArcGIS GeoDatabase Structure .....	17
First Pass Evaluation of Potential Impediments.....	17
CONCLUSION.....	27
REFERENCES .....	28
APPENDIX A.....	31
APPENDIX B .....	37
FIRST PASS SURVEY PROTOCOL .....	39
First Pass Assessment Preparation .....	39
What to Survey .....	39
Field Crews.....	39
Location of Stream Crossings.....	39
Site Visit .....	39
Field Preparation.....	39
First Pass Data Collection Entry .....	41
APPENDIX C .....	63
APPENDIX D.....	73



*[This page has been intentionally left blank]*

## INTRODUCTION

This document describes the Task 1 data collection and evaluation of potential fish passage barriers on the main stem of the San Joaquin River and bypass system, from Friant Dam to the Merced River confluence. The Department of Water Resources is performing this work as part of a Fish Passage Evaluation Plan that will be implemented for the San Joaquin River Restoration Program to identify and prioritize fish passage barriers in the Restoration Area in an effort to minimize migration delays, stranding, and mortality of juvenile and adult salmon and other native fish. The fish passage evaluation plan (2009) follows a phased approach separated in three main tasks. Task 1 consists of an initial look at the structures within the project area; Task 2 will conduct a more thorough hydraulic evaluation of structures identified in Task 1; and Task 3 recommends improvement or repair to structures that were identified as barriers in both Tasks 1 and 2. This document details Task 1 of the SJRRP fish passage evaluation to identify passage impediments to migration of juvenile and adult salmon and other native fish.

The San Joaquin River Restoration Program (SJRRP) was established to implement the conditions of the Settlement to restore the San Joaquin River. The Settlement has two main goals; one of those goals is to restore a self-sustaining salmon fishery in the river. To restore a salmon fishery in the San Joaquin River, SJRRP managers need to provide adequate flows and perform channel and structural modifications, as necessary, to ensure adult and juvenile passage during the migration periods of both spring- and fall-run Chinook salmon. The SJRRP is a multi-agency federal, state, and local effort to plan and implement restoration projects along the San Joaquin River. Under the SJRRP, the Fisheries Management Work Group (FMWG) is responsible for planning and coordinating the efforts to implement the sections in the Settlement related to meeting the Restoration Goal and ensuring adequate fish passage.

To this end, the FMWG established a habitat objective to provide passage conditions that allow 90 percent of migrating adult and 70 percent of migrating juvenile Chinook salmon to successfully pass to suitable upstream and downstream habitat, respectively, during all base flow schedule component periods and water year types of the Settlement, except the Critical-Low water year type (SJRRP 2010). Previous studies have documented existing known potential fish passage impediments on the San Joaquin River system. These studies include a Technical Memorandum (TM) on the Potential Barriers to Migrating Steelhead and Chinook Salmon on the San Joaquin River by Jones & Stokes (2001), a San Joaquin River Restoration Study Background Report by McBain & Trush (2002), and Bulletin 250 Fish Passage Improvement by DWR (2005) that have evaluated and listed passage problems within the restoration area. These studies did not include the entire SJRRP project area and use different criteria to identify potential barriers.

Therefore, the purpose of this fish passage evaluation is to provide a list of structures that have the potential to impede fish passage of all species of fish, in the main channel of the San Joaquin River and sections of the Eastside Bypass Channel, with emphasis on salmonids. This study will evaluate potential fish passage barriers on the main stem of the San Joaquin River and bypass system, from Friant Dam to the Merced River confluence, and will include an inventory of the

types and location of structures on the system. This analysis will only consider structures in evaluating barriers to fish migration. Specifically, the definition of a fish passage barrier for this study includes any natural channel structures and animal or human-made crossings and structures over or through the San Joaquin River or bypasses designed to pass stream flow that will create a total, partial, or temporary barrier. In this document, all natural and man-made potential fish passage barriers will be described as structures. Examples of potential fish passage barriers include crossings that are typically paved roads, unpaved roads, railroads, trails, and paths that can include culverts, bridges, and low-water crossings such as paved and unpaved fords; structures designed to store or pass flows that are typically dams, weirs, control structures, diversions, and canal or pipeline crossings; and natural channel barriers that typically include landslides, waterfalls, boulder cascades, and debris. Many of these types of human-made and natural barriers create temporary, partial, or complete barriers for fish passage during spawning migrations and juvenile salmonids during seasonal movements.

This document details Task 1 of the SJRRP fish passage evaluation to identify passage impediments to migration of juvenile and adult salmon and other native fish. In this initial task, work includes the identification and data collection of potential fish passage barriers, identification of the passage criteria to allow an initial evaluation of potential barriers, and identification of potential barriers for further study. The California Department of Water Resources, South Central Region Office (DWR-SCRO), performed the work to identify potential fish passage issues along the Restoration Area and recruited fisheries expertise from the California Department of Fish and Game. The DWR-SCRO has performed similar fish passage evaluations on the Calaveras River and for stream crossings under California Department of Transportation highways. The plan to collect this information was consulted with the FMWG and the SJRRP Technical Advisory Committee. This report and data collection was primarily performed by water resources engineers based on criteria that had been developed by the California Fish and Game and the National Marine Fisheries. Information from Jones & Stokes (2001), McBain & Trush (2002), and DWR (2005) was used to develop a complete list of structures that was compared with the first pass criteria to determine the structures that are a barrier to fish passage in the river and appropriate flood bypasses. A GeoDatabase was created to input information on identified structures. The database will be used to incorporate the features of each structure against fish passage criteria to perform the initial evaluation of the structures.

The Task 1 document provides detail on field assessment procedures and protocols for the initial field survey of existing and newly identified impediments and developed initial evaluation criteria to determine which structures are a potential fish passage barrier and those structures that will need further evaluation. The list of channel and structural passage impediments will be further evaluated in Task 2 of the fish passage evaluation. Fish passage problems within the channels due to shallow flow depths in large flat channels will be considered during Task 2. It is expected that this information will be used by the SJRRP to prioritize studies and develop alternatives to improve fish passage along the San Joaquin River and flood bypasses prior to the initial salmon run.

## IDENTIFICATION OF POTENTIAL FISH PASSAGE BARRIERS

In this task, all structures on the river and flood bypasses were identified to be evaluated further in Task 2 for their potential as fish passage barriers within the project area. The process to identify the barriers included a review of already existing barriers defined in previous studies, a review of existing hydraulic models of the SJR, and referencing recent aerial photography. Structures that were identified during review include dams, road crossings, bridges, culverts, flood control channels, erosion control structures, canal and pipeline crossings, unscreened water diversions, and gravel mining pits.

This study only evaluated structures that would have an impact on migration of fish in the San Joaquin River channel and flood bypasses (Table 1). During review, several references identified structures that were ruled out because this evaluation will not identify off-channel structures like diversions or gravel mining pits that have the potential for fish entrainment. In addition, tributaries to the San Joaquin River that could cause fish straying or structures that are potential barriers on the tributaries are not going to be included in this evaluation. The following section details the work performed to identifying the structures.

**Table 1.**  
Barriers to fish passage and their potential impacts

<b>Barrier Category</b>	<b>Definition</b>	<b>Potential Impacts</b>
Total	Impassable to all fish at all flows.	Exclusion of all species from portions of a watershed.
Partial	Impassable to some fish species, during part or all life stages at all flows.	Exclusion of certain species during their life stages from portions of a watershed.
Temporary	Impassable to all fish at certain flow conditions.	Delay in movement beyond the barrier for some period of time.

*Sources:* adapted from CA Salmonid Stream Habitat Restoration Manual (DFG 1998), Robison et al. 1999

### Existing List of Potential Barriers

In 2001, Jones & Stokes prepared a technical memorandum (TM) (Jones & Stokes 2001) for the Friant Water Users Authority (FWUA) and the Natural Resources Defense Council (NRDC) that identified and measured potential barriers for movement of adult and juvenile steelhead and Chinook salmon based on criteria developed for all life stages of these organisms. The TM considered vertical height, velocity, and depth criteria for identifying barriers on the SJR between Friant Dam and the Merced River, including the Eastside and Mariposa Bypasses. In addition, the TM developed passage solutions including modification of barriers or development of passage facilities such as fish ladders.

In 2002, McBain & Trush identified physical barriers for migrating fish as part of the San Joaquin River Restoration Study Background Report (McBain & Trush 2002) prepared for the FWUA and NRDC. Fish resources were summarized as part of the study and physical barriers were identified when considering the habitat connectivity of the San Joaquin River. Only significant structures in the study area that are impediments to both upstream and downstream fish movement were illustrated in the study.

In 2005, DWR published Bulletin 250 (DWR 2005) that identified man-made structures in the Central Valley and Bay Area rivers and streams particularly in the watersheds of the Sacramento and San Joaquin rivers. Bulletin 250 published an inventory of potential barriers based on data compiled from 395 sources. The list of barriers for Fresno, Merced, and Madera include several on the San Joaquin River. Bulletin 250 provided the report findings to the Fish Passage Decision Support System (FPDSS), U.S. Fish and Wildlife Service. The FPDSS, <http://fpdss.fws.gov/>, is an online application funded by the U.S. Fish and Wildlife Service that makes information about barriers to fish passage in the U.S. available to policy makers and the public. As part of our evaluation, this site was accessed to determine if any additional barriers were added since the 2005 report but no new information was available through the web site. Information on this site includes diversions like pumps, drains, etc. that potentially need to be screened, but these diversions will not be detailed in this evaluation.

A total of 61 structures were identified in these previous studies that were reviewed for inclusion in this analysis. The location details of these structures are listed in Appendix A including their location based on the SJR river mile and include a brief description. The criterion for selection of these barriers in the previous documents is not the same as the criterion for this analysis, and some of the structures identified in these studies included structures on the San Joaquin River that were not a fish passage issue, but would attribute to fish straying or entrainment. These structures will not be part of this analysis. The barriers identified in these documents are shown in Figure 1 (Appendix A).

## **Identification of Additional Structures**

Once the existing structures were identified from previous studies, additional work was done to identify other structures that would pose a potential barrier to fish passage based on the criteria of this evaluation. Aerial photographs from 2008 LiDAR mapping (RBF 2008) were reviewed to identify any crossings, structures, or natural barriers that were not previously identified. The current San Joaquin River HEC-RAS model (USACE 2005) was also used to identify any modeled structures and culverts that were not already identified by the references or the aerial photos. The HEC-RAS model was developed in 2002 as a one-dimensional hydraulic model encompassing the project area from Friant Dam to the confluence with the Merced River. The model was developed by Mussetter Engineering Inc. for the FWUA and NRDC. A total of 50 new structures were identified in this analysis.

## **Selection of Structures to be Evaluated**

A total of 61 structures were identified in the previous studies, but since fish straying and entrainment will not be looked at in this analysis, only structures that have the potential as a fish passage barrier were further identified. All locations in Appendix A that are gravel mining pits, diversions that need to be screened, and those that are located on tributaries were filtered out and will not be included in this analysis. Using this criterion, the list of barriers defined by the previous studies was reduced to 18 structures. These 18 structures were combined with the 50 new structures from the HEC-RAS model and aerial photographs for a total of 68 structures will be evaluated in the SJRRP fish passage evaluation. Table 2 lists the previously identified barriers with the newly identified structures. Figure 2 shows a map of the structures within the study area.

**Table 2.**  
Newly identified barriers and existing first pass barriers

Identification Number	River Mile	Potential Barrier	Description
Mainstem of San Joaquin River (SJR)			
1*	267.5	Dam	Friant Dam
2	266.8	Bridge	North Fork Road
3	266.8	Debris	Debris from previous North Fork Road Bridge
4	266.0	Misc.	
5	265.0	Misc.	
6*	262.3	Crossing	
7	260.7	Misc.	Chute , Natural Barrier
8	260.4	Misc.	
9*	258.5	Crossing	Vulcan Road with culverts under road
10	255.2	Crossing	Frontage Road
11	255.2	Bridge	North and South Highway 41 Bridges
12*	253.4	Crossing	
13*	253	Crossing	Culverts between gravel-mining ponds
14	245.2	Crossing	Railroad Crossing
15	243.2	Crossing	Railroad Crossing
16*	243.1	Bridge	North and South Highway 99 Bridges
17*	240.7	Crossing	
18	234.2	Bridge	Skaggs Bridge, Highway 145
19*	229.0	Crossing	Stuart/Nees Road
20*	227.0	Dam	Earthen dam just downstream Gravelly Ford
21*	216.1	Diversion	Chowchilla Bifurcation Dam
22*	215.0	Control	Lone Willow Slough Control Structure
23*	211.8	Crossing	San Mateo Avenue
24*	204.7	Dam	Mendota Dam
25	195.1	Bridge	Avenue 7-1/2
26*	182.0	Dam	Sack Dam
27	173.9	Bridge	Santa Rita Bridge, Highway 152
28	168.4	Control	Control Structure
29*	168.4	Control	Sand Slough Connector
30	168.0	Crossing	
31*	163.1	Crossing	Farm road crossing with culverts
32	157.2	Crossing	Erreca Road
33	156.2	Crossing	
34*	153.4	Crossing	Farm road with culverts
35*	147.6	Control	Mariposa Bypass control structure and drop structure
36	146.1	Misc.	
37	145.0	Misc.	
38	143.2	Misc.	
39	143.1	Misc.	
40	137.7	Misc.	
41	137.7	Misc.	
42	132.8	Bridge	Highway 165
43	125.1	Bridge	Highway 140
Bypass System			
44	EB-0.6	Bridge	
45	EB-3.4	Bridge	
46	EB-5.7	Crossing	
47	EB-6.7	Bridge	

Identification Number	River Mile	Potential Barrier	Description
48	EB-9.2	Control	Eastside Bypass
49	MB-3.36	Control	Mariposa Bypass
50	EB-10.8	Crossing	
51	EB-11.3	Crossing	Dan McNamara
52	EB-12.0	Bridge	Sandy Mush Road
53	EB-15.8	Crossing	Chamberlain Road
54	EB-18.2	Crossing	
55	SS-0.0	Bridge	Harmon Road
56	EB-20.6	Bridge	
57	EB-24.2	Bridge	Highway 152
58	EB-25.9	Crossing	Avenue 21
59	EB-28.2	Crossing	
60	EB-30.0	Crossing	
61	EB-30.8	Crossing	Avenue 18-1/2
62	EB-32.3	Crossing	
63	EB-35.0	Bridge	
64	EB-35.1	Drop Structure	
65	EB-35.5	Drop Structure	
66	CB-1.5	Bridge	
67	CB-7.3	Bridge	
68	CB-8.7	Crossing	

\* *Previously identified barrier*

*EB – Eastside Bypass post mile on left levee*

*MB – Mariposa Bypass post mile on left levee*

*SS – Sand Slough post mile on left levee*

*CB – Chowchilla Bypass post mile on left levee*



*[This page has been intentionally left blank]*

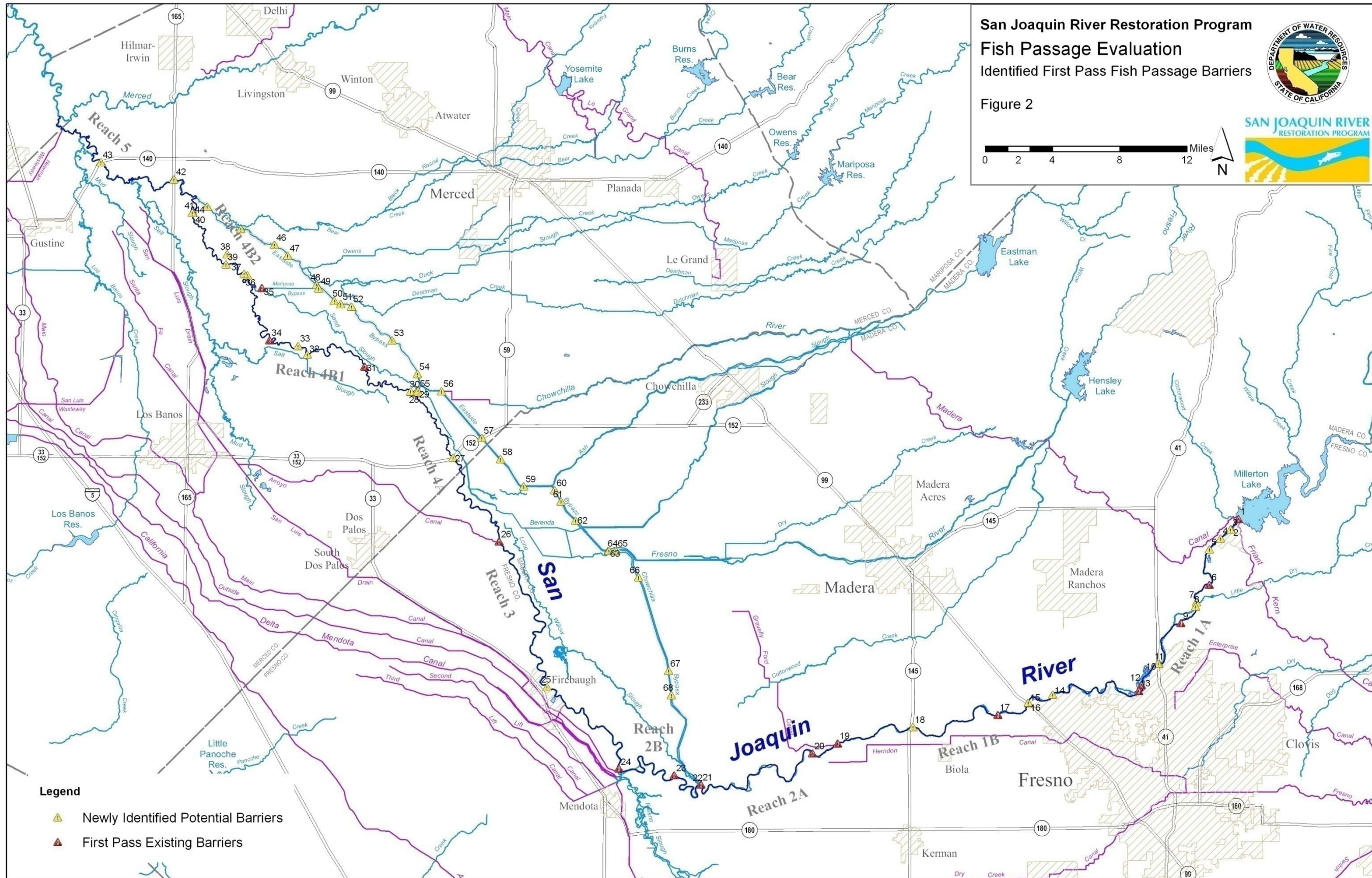

*[This page has been intentionally left blank]*

## INITIAL EVALUATION CRITERIA

In evaluating the structures for fish passage, significant criteria have been developed by the California Department of Fish and Game (CDFG) and the National Marine Fisheries Service (NMFS) to evaluate many different types of stream crossings. These criteria are generally based on the flow velocities within the structure, jump height to enter a structure, drop distance at the exit of a structure, and pool depths upstream and downstream of a structure. The purpose of these criteria is to determine if a structures' design is blocking or impeding fish movement. Inadequate structural designs will promote stress or injure or disorient fish, increasing their vulnerability to predation and disease. Cumulative effects of these barriers may decrease the physical abilities of individual fish to migrate (Jones & Stokes 2001).

In evaluating structures to determine if they are a temporary or permanent barrier, a rigorous analysis is required that includes collecting a significant amount of physical information on the structure's size and shape, channel and floodplain characteristics, and information on the magnitude and frequency of flows in the stream. Hydraulic modeling is required to simulate the physical characteristics of the structure and stream to develop the velocities, water depths, and requirement of fish to pass within the structure. Furthermore, the species and life stage of all fish to be evaluated needs to be included in this analysis. This analysis can be very time-consuming and would not be feasible for every structure that has been identified. Therefore, initial evaluation criteria were developed to categorize each structure on its potential to prevent or restrict fish movement.

### Initial Evaluation Tool

An initial evaluation tool was used to characterize the structure into three categories: not a barrier, a definite barrier, or need more information on whether it is a barrier or not. The primary factors that determine the extent to which fish passage will be impacted by the physical structure of a stream crossing are: 1) the degree of constriction the crossing has on the stream channel; 2) the degree to which the streambed is allowed to adjust vertically; 3) the length of stream channel impacted by the crossing, and; 4) the degree to which the stream velocity has been increased by the crossing. For unimpaired fish passage, it is desirable to have a crossing that is a large percentage of the channel bankfull width, allows for a natural variation in bed elevation, and provides bed and bank roughness similar to the upstream and downstream channel (CDFG 2002).

In this evaluation, the CDFG (1998, 2002) and NMFS (2008, 2001, 2000) criteria were used to understand what physical characteristics of the structure are most important in determining fish passage. Table 3 shows what physical characteristics are key in determining an initial evaluation of a structure's effect on fish passage.

**Table 3.**  
Typical fish passage attributes and the correlating biological factors

<b>Attribute</b>	<b>General Criteria</b>	<b>Biological Factors</b>
Length and Slope	Water Velocity	Swimming Speed
Width and Inlet Depth	Water Depth	Submergence (sufficient depth for swimming)
Pool/Height	Drop/Jump	Jumping Ability

The characteristics of each structure and channel were collected in First Pass surveys of each structure. The physical features of each site include the structure’s length, outlet drop, slope, elevation of the tailwater control relative to structure inlet, outlet, and pool invert, ratio of structure width to channel width and whether the channel substrate is continuous over or through the structure. Two of the main factors that were used in this initial evaluation include the width of the structure and the inlet/outlet conditions.

*Width:* Width is an important component in determining adequate fish passage over or through a structure. The structure’s width can be compared to the natural channel width to consider if the structure may have an impact on the velocity criteria. If the barrier has a structure width that is less than the channel width there may be a contraction that could cause a hydraulic jump or increased velocity that would cause a barrier for passage.

*Inlet/Outlet:* Structures with too high of a jump or drop or pools too far from the structure or not deep enough could also be an important barrier to fish passage. Furthermore, when a concrete apron or riprap is present, fish may also have trouble passing the structure. A structure with these characteristics may be a barrier to fish.

The First Pass surveys included a quick assessment of the structure by analyzing preliminary measurements and photographic data to allow the initial evaluation. The data collected during the First Pass surveys are described in the First Pass Data Collection section.

### **Initial Evaluation Categories**

The result of the initial evaluation of each structure categorizes each structure as Green/Gray/Red as it relates to fish passage.

- Green – The location is assumed adequate for passage of all salmonid species throughout all salmonid life stages and stream flows.
- Gray – The location may not be adequate for all salmonid species at all their life stages. More information is needed to evaluate the structure.
- Red – The location will likely fail to meet DFG and NMFS passage criteria at all flows for strongest swimming species presumed present.

Once each structure has been placed in its appropriate category, the need for additional analysis is established. Green sites are assumed to be adequate for fish passage and will not require any further evaluation. These sites are generally locations that resemble the adjacent natural channel and will not impede fish migration. Gray sites will need further evaluation to determine whether it is a barrier or not, and will be further evaluated in Task 2 of the fish passage evaluation. In Task 2—called Second Pass—topographic surveys of the site and hydraulic modeling will be performed to evaluate the structure’s ability to pass fish. Red sites are likely barriers and no additional analysis is needed to categorize these structures. They will automatically be placed onto the list of structures that will need to be removed or modified to allow adequate fish passage in the stream (work performed in Task 3 of the fish passage evaluation).

The analysis used to place each structure in its relevant category has been defined in the California Department of Fish and Game’s *California Salmonid Stream Habitat Restoration Manual* (DFG 1998). Figure 4 shows a flow chart for culverts developed by Taylor, R. N. & M. Love (2003) to determine which category the site will be labeled. Figure 5 was developed for this initial evaluation and applies the same logic as Figure 4 to include additional structures, like low flow crossings, bridges, control structures, and natural barriers. The figure that was developed for use by CDFG was too specific to culverts and was not able to capture the other structures identified during this evaluation.

**CALIFORNIA SALMONID STREAM  
HABITAT RESTORATION MANUAL**

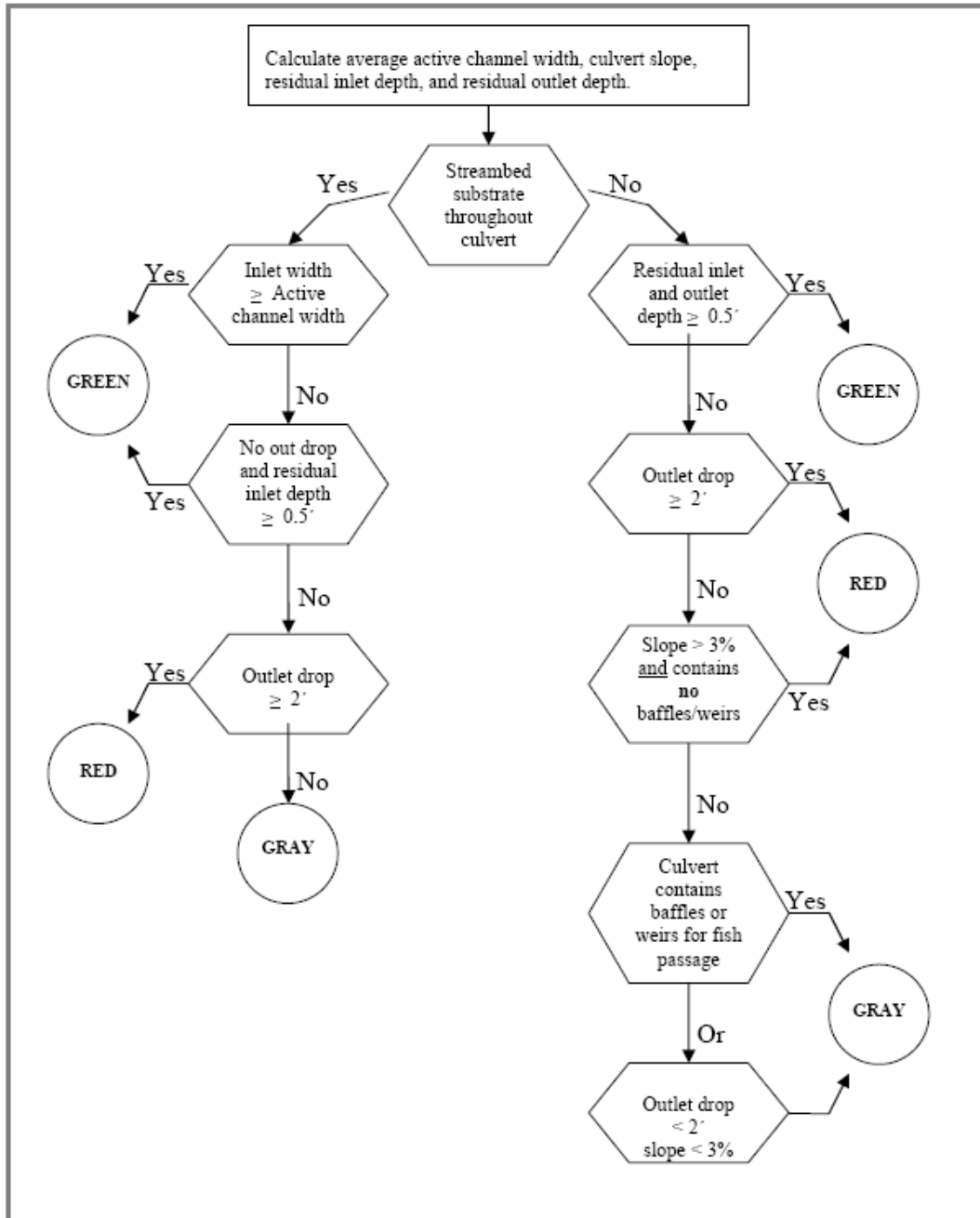

Source: Taylor, R. N. & M. Love, 2003

**Figure 4.** Culvert GREEN, GRAY, RED fish passage initial evaluation

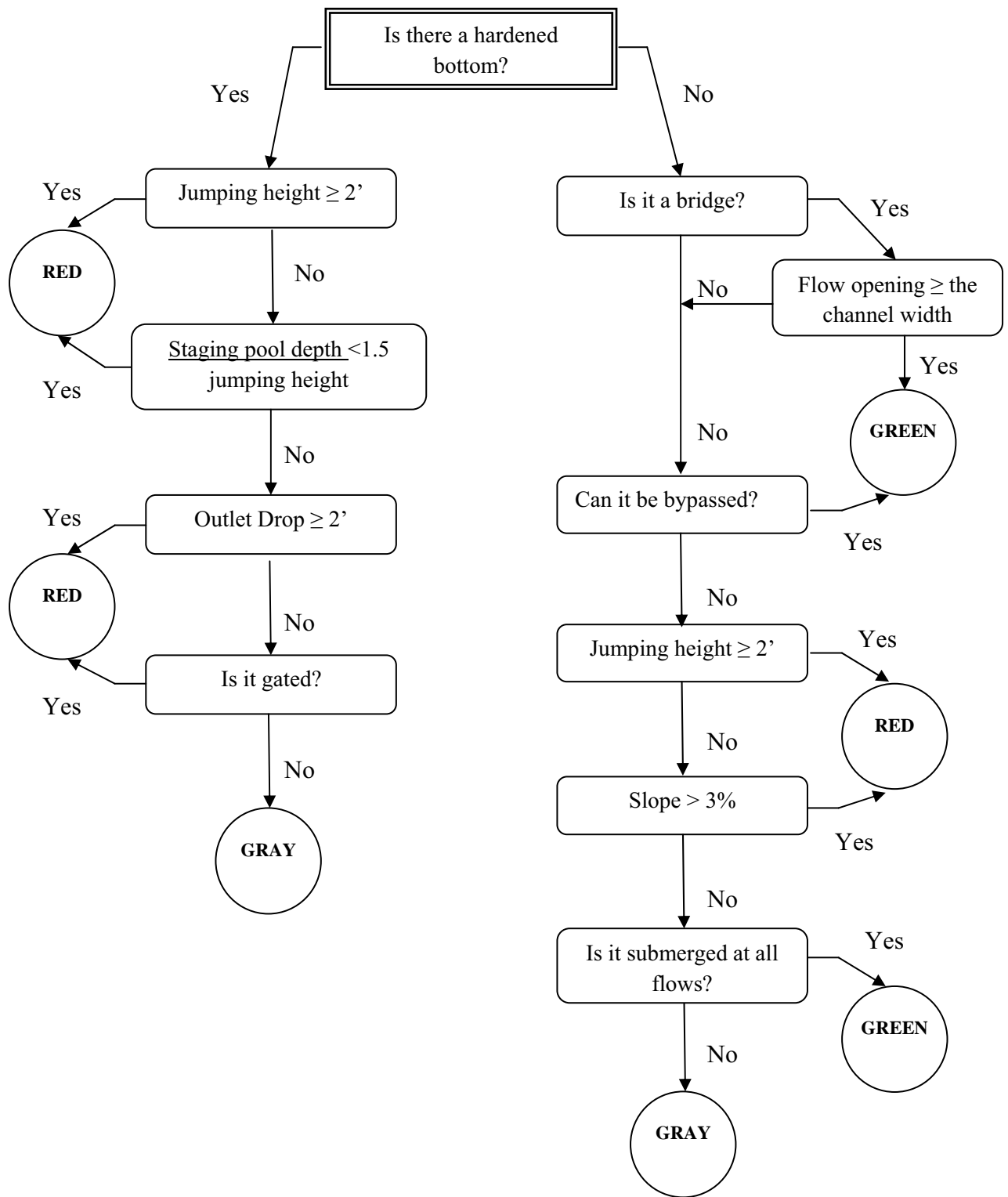

**Figure 5.** GREEN, GRAY, RED fish passage initial evaluation for miscellaneous structures.



## FIRST PASS DATA COLLECTION

In order to perform an initial evaluation of the 68 structures, an initial field survey was performed on these structures. These surveys are called First Pass surveys as previously defined by Caltrans for the Fish Passage and Culvert Identification Program (Taylor, R. N. & M. Love, 2003). The First Pass surveys were used to collect physical data of each structure including measurements and photographs. The collected data will assist in developing an initial evaluation of the structures by identifying characteristics that will give an indication of adequate designs for fish passage based on NMFS and DFG standard criteria.

The First Pass survey was used to collect physical measurements that affect fish passage for each structure type. Bridges, dams, control structures, weirs, low flow crossings, control structures and culverts may all require the collection of different physical information. The physical features of the site includes the length, ratio of structure width to channel width, outlet drop, slope, elevation of the tailwater control relative to structure inlet, outlet, and pool invert, and whether the channel substrate is continuous over or through the structure. These physical measurements are easy to collect without the use of survey equipment and can be collected quickly.

This information is recorded on the Fish Passage Inventory Data Sheet along with additional information that includes: a description of the type and condition of each structure; structure dimensions; stream habitat; GPS waypoints; a site sketch and photographs. The Fish Passage Inventory Data Sheet was completed at all locations. All information in the data sheet should be filled out completely. The data description and data sheet is located in Appendix B and Appendix C, respectively.

Consistent methods for collecting data to evaluate passage of juvenile and adult salmonids through potential stream barriers were developed and are defined in Appendix B. Most of this guidance was taken from the California Salmonid Stream Habitat Restoration Manual in Part IX for Fish Passage Evaluation at Stream Crossings. Adaptations to the Fish Passage Inventory Data Sheet were included to better fit the needs of the restoration program and the definition and criteria of a fish passage barrier.

## **RESULTS OF FIRST PASS EVALUATION**

The First Pass surveys were completed during the months of July and August 2010 with flow releases from Friant Dam to the San Joaquin River that averaged 331 cfs and ranged from 295 - 361 cfs. The First Pass surveys were performed on 45 of the 68 structures identified as potential barriers in the San Joaquin River and flood bypasses. An additional structure was added to the evaluation after seeing it in the field and several more structures were evaluated based on existing data gathered in the field or from a distance. The structures that were not surveyed could not be accessed due to lack of entry permits, locked gates, steep terrain, or water depth. Structures along the Chowchilla Bypass and lower Eastside Bypass were not surveyed because of current plans that do not include them in the project area; these have the potential to be surveyed in the future or if current plans change. Once the surveys were completed for each structure, the data was input into an ArcGIS GeoDatabase and run through the criteria flow chart, to establish whether a site was considered Green/Gray/Red. It should be noted that this initial evaluation only looked at individual factors that would affect fish passage for each individual structure. The cumulative effects of each structure on fish migration were not evaluated during this study. The following discusses the process and results of this initial evaluation.

### **ArcGIS GeoDatabase Structure**

The first pass data that was collected in the field was entered into an ArcGIS GeoDatabase. The ArcGIS GeoDatabase was created using ArcGIS Desktop 9.3. The GeoDatabase is a collection of geographic datasets of various types held in a common file system folder. Data on each structure was collected in the field with a handheld GPS and reflects the data fields that are on the Fish Passage Inventory Data Sheets. The field data was downloaded in the GeoDatabase and layers were created that include point data and attributes from the First Pass surveys. Data gathered for each structure was used to create a base map with attributes, tables, and features. Figure 6 displays the structure of the GeoDatabase.

### **First Pass Evaluation of Potential Impediments**

The First Pass survey data input into the ArcGIS was filtered with the criteria set forth in Figures 4 and 5. The GeoDatabase was then used to place each structure into one of the three fish passage categories. Table 4 shows the results of the initial First Pass evaluation of the structures. Figure 7 displays the location map by rank color. Tables 5, 6 and 7 list the criteria that decided the indicator attribute from the flow chart organized by rank.

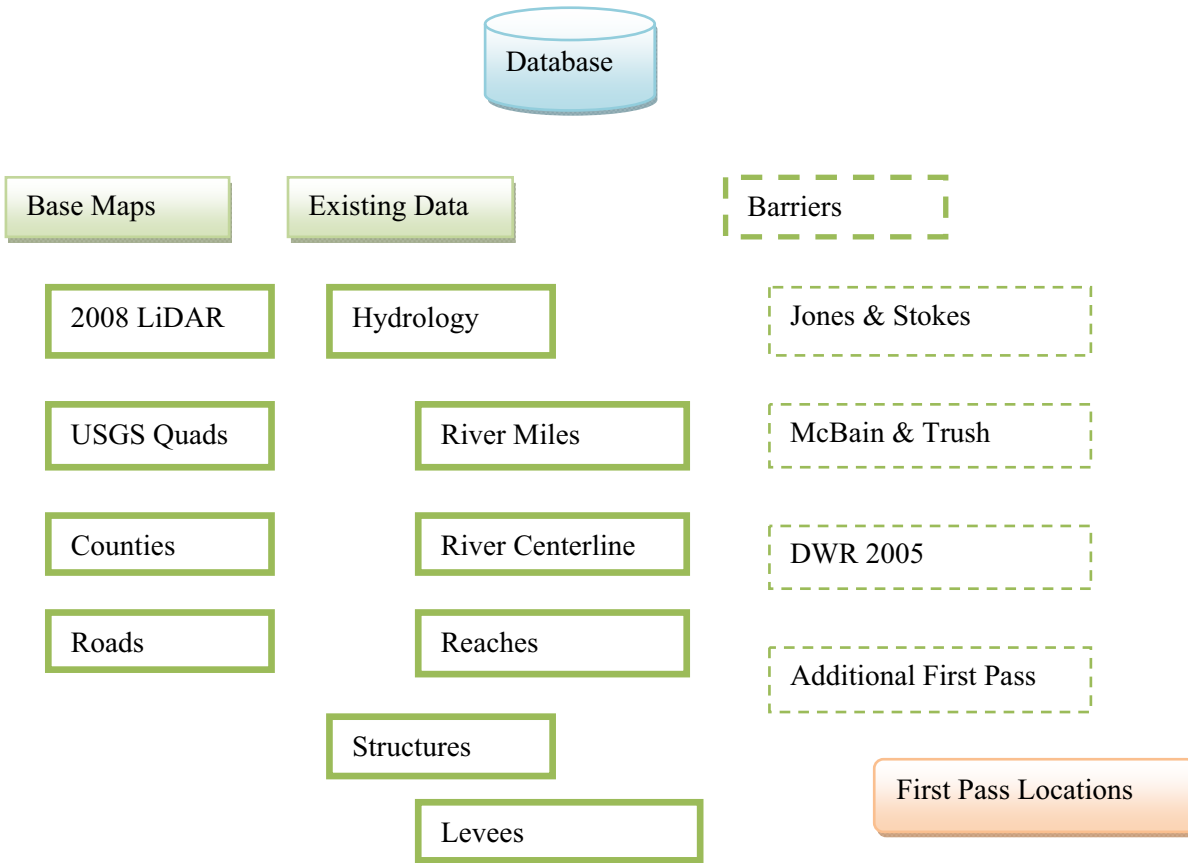

**Figure 6.** ArcGIS GeoDatabase Structure

ArcGIS GeoDatabase analysis was used to categorize site structures as Green, Gray, or Red. Structures identified as Green are assumed not to be a barrier to fish migration and no further analysis will be performed on these structures. Structures that are labeled as Gray will be placed on a list of structures that need to be evaluated using a Second Pass analysis. These structures could not be confirmed as a definite barrier so additional data collection and analysis is needed before the structures can be fully evaluated for fish passage. This analysis is described as Task 2 of the Fish Passage Evaluation Plan. Structures that are labeled Red will automatically be considered a barrier to fish passage and will be evaluated during Task 3 of the Fish Passage Evaluation Plan. These structures will likely need to be removed or modified to prevent being an impediment to fish migration.

In evaluating the results of this initial evaluation, 28 structures were identified as Green, 13 structures were identified as Gray, and 8 structures were identified as Red. A general description of these structures is located in Appendix D with photos and a brief evaluation of each location visited. Sites that were identified as Green were mostly bridges with a natural bottom where the

bridge flow opening was greater or equal to the channel width. Gray sites were typically low flow crossing or channel weirs (natural and man-made) with jumping heights that would be greater than two feet at some flows. Additional gray sites included any bridges and culverts that need hydraulic modeling to determine profile slopes and velocities. Typical red sites were structures that were gated or known barriers due to the structures height or outlet drop. Locations that were identified as Green or Red is assumed to not require any work during the Second Pass evaluation, but may be further evaluated if requested.

**Table 4.**  
**Barrier Rankings**

Identification Number	River Mile	Potential Barrier	Title	Rank	Accessed	Desc. Page
Mainstem of San Joaquin River (SJR)						
1*	267.5	Dam	Friant Dam	Red	No	
2	266.8	Bridge	North Fork Road, Road 206	Green	Yes	<a href="#">66</a>
3	266.8	Debris	Debris	Green	Yes	66
4	266.0	Misc.	Lost Lake Rock Weir #1	Gray	Yes	67
5	265.0	Misc.	Lost Lake Rock Weir #2	Gray	Yes	68
6*	262.3	Bridge	Ledger Island		No	
7	260.7	Misc.	Riffle	Green	Yes	70
8	260.4	Misc.	Historical Earthen Diversion	Green	Yes	
9*	258.5	Crossing	Vulcan Crossing	Green	Yes	71
10	255.2	Bridge	Frontage Road	Green	Yes	72
11	255.2	Bridge	Highway 41 Bridges	Green	Yes	73
12*	253.4	Crossing	Retired Crossing	Green	Yes	74
13*	253	Crossing	Culverts between gravel-mining ponds - Removed	Green	Yes	75
14	245.2	Crossing	Railroad Crossing	Green	Yes	77
15	243.2	Crossing	Railroad Crossing	Green	Yes	78
16*	243.1	Bridge	Highway 99 Bridges	Green	Yes	79
17*	240.7	Crossing	Donny Bridge	Gray	Yes	81
18	234.2	Bridge	Skaggs Bridge, Highway 145	Green	Yes	82
19*	229.0	Crossing	Stuart/Nees Road		No	
20*	227.0	Dam	Earthen dam just downstream Gravelly Ford		No	
21*	216.1	Diversion	Chowchilla Bifurcation	Red	Yes	85
22*	216.1	Control	San Joaquin River Bifurcation	Red	Yes	83
23*	211.8	Crossing	San Mateo Avenue	Gray	Yes	87
24*	204.7	Dam	Mendota Dam		No	
25	195.1	Bridge	Avenue 7-1/2	Green	Yes	89
26*	182.0	Dam	Sack Dam	Red	No	
27	173.9	Bridge	Santa Rita Bridge, Highway 152	Green	Yes	90
28	168.4	Control	San Joaquin River Reach 4B Headgates	Red	Yes	91
29*	168.4	Diversion	Sand Slough Connector	Gray	Yes	93
30	168.0	Bridge	Washington/Indiana Road	Green	Yes	95
31*	163.1	Crossing	Farm road crossing with culverts		No	
32	157.2	Bridge	Turner Island Road	Green	Yes	96
33	156.2	Crossing			No	
34*	153.4	Crossing	Farm road with culverts		No	
35*	147.6	Diversion	Mariposa Bypass control structure and drop structure	Red	Yes	97
36	146.1	Misc.	Beaver Dam #5	Gray	Yes	99
37	145.0	Misc.	Beaver Dam #4	Gray	Yes	100
38	143.2	Crossing	Refuge Low Flow Crossing	Gray	Yes	102
39	143.1	Misc.	Beaver Dam #3	Gray	Yes	104
40	137.7	Misc.	Beaver Dam #2	Gray	Yes	105
41	137.7	Misc.	Beaver Dam #1	Gray	Yes	106
42	132.8	Bridge	Highway 165	Green	Yes	108
43	125.1	Bridge	Highway 140	Green	Yes	109

Identification Number	River Mile	Potential Barrier	Description	Rank	Accessed	Desc. Page
<b>Bypass System</b>						
44	EB-0.6	Bridge	Unnamed Bridge	Green	Yes	111
45	EB-3.4	Bridge	Unnamed Bridge	Green	Yes	113
46	EB-5.7	Misc.	Barbed Wire Fence	Green	Yes	
47	EB-6.7	Bridge	Greenhorn Road	Green	Yes	115
48	EB-9.2	Control	Eastside Bypass Bifurcation	Red	Yes	117
49	MB-3.36	Control	Mariposa Bypass Bifurcation	Red	Yes	119
50	EB-10.8	Bridge	Eastside Bypass Crossing	Green	Yes	121
51	EB-11.3	Crossing	Dan McNamara Road	Gray	Yes	122
52	EB-12.0	Bridge	Sandy Mush Road	Green	Yes	124
53	EB-15.8	Bridge	Chamberlain Road	Green	Yes	126
54	EB-18.2	Crossing	Iest Low Flow Crossing	Green	No	127
55	SS-0.0	Bridge	Washington Road	Green	Yes	128
56	EB-20.6	Bridge			No	
57	EB-24.2	Bridge	Highway 152		No	
58	EB-25.9	Crossing	Avenue 21		No	
59	EB-28.2	Crossing			No	
60	EB-30.0	Crossing			No	
61	EB-30.8	Crossing	Avenue 18-1/2		No	
62	EB-32.3	Crossing			No	
63	EB-35.0	Bridge			No	
64	EB-35.1	Structure			No	
65	EB-35.5	Structure			No	
66	CB-1.5	Bridge			No	
67	CB-7.3	Bridge			No	
68	CB-8.7	Crossing			No	
69	EB-0.6	Misc.	Rock Weir	Gray	No	130

\* *Previously identified barrier*

*EB – Eastside Bypass post mile on left levee*

*MB – Mariposa Bypass post mile on left levee*

*SS – Sand Slough post mile on left levee*

*CB – Chowchilla Bypass post mile on left levee*

*[This page has been intentionally left blank]*

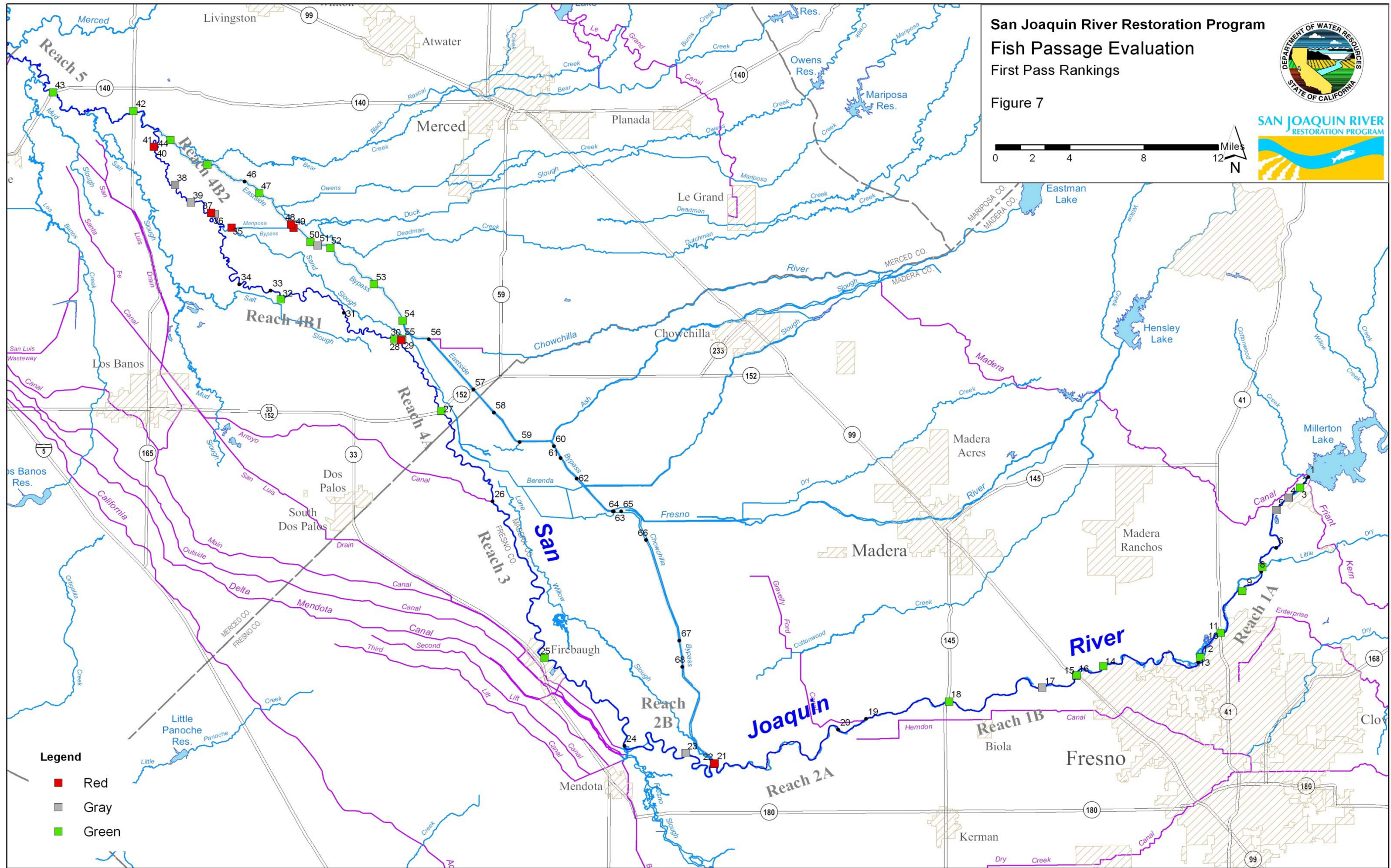



*[This page has been intentionally left blank]*

**Table 5**  
Ranking Evaluation for Green

Identification Number	Description	Criteria Attribute
2	North Fork Road, Road 206	Natural bottom, Flow opening $\geq$ the channel width
3	Debris	Flow opening $\geq$ the channel width
7	Riffle	Submerged
8	Historical Earthen Diversion	Not present
9	Vulcan Crossing	Natural bottom, Submerged
10	Frontage Road	Natural bottom, Flow opening $\geq$ the channel width
11	Highway 41 Bridges	Natural bottom, Flow opening $\geq$ the channel width
12	Retired Crossing	Not present
13	Culverts between gravel-mining ponds - Removed	Not present
14	Railroad Crossing	Natural bottom, Flow opening $\geq$ the channel width
15	Railroad Crossing	Natural bottom, Flow opening $\geq$ the channel width
16	Highway 99 Bridges	Natural bottom, Flow opening $\geq$ the channel width
18	Skaggs Bridge, Highway 145	Natural bottom, Flow opening $\geq$ the channel width
25	Avenue 7-1/2	Natural bottom, Flow opening $\geq$ the channel width
27	Santa Rita Bridge, Highway 152	Natural bottom, Flow opening $\geq$ the channel width
30	Washington/Indiana Road	Natural bottom, Flow opening $\geq$ the channel width
32	Turner Island Road	Natural bottom, Flow opening $\geq$ the channel width
42	Highway 165	Natural bottom, Flow opening $\geq$ the channel width
43	Highway 140	Natural bottom, Flow opening $\geq$ the channel width
44	Unnamed Bridge	Natural bottom, Flow opening $\geq$ the channel width
45	Unnamed Bridge	Natural bottom, Flow opening $\geq$ the channel width
46	Barbed Wire Fence	Flow opening $\geq$ the channel width
47	Greenhorn Road	Natural bottom, Flow opening $\geq$ the channel width
50	Eastside Bypass Crossing	Natural bottom, Flow opening $\geq$ the channel width
52	Sandy Mush Road	Natural bottom, Flow opening $\geq$ the channel width
53	Chamberlain Road	Natural bottom, Flow opening $\geq$ the channel width
54	Iest Low Flow Crossing	Will be submerged at all flows
55	Washington Road	Natural bottom, Flow opening $\geq$ the channel width

**Table 6**  
Ranking Evaluation for Gray

Identification Number	Description	Criteria Attribute
4	Lost Lake Rock Weir #1	Height $\geq 2'$ , but Jumping Height $\leq 2'$ at some flows
5	Lost Lake Rock Weir #2	Height $\geq 2'$ , but Jumping Height $\leq 2'$ at some flows
17	Donny Bridge	Flow opening $\leq$ the channel width
23	San Mateo Avenue	Height $\geq 2'$ , culvert
29	Sand Slough Connector	Flow opening $\leq$ the channel width
36	Beaver Dam #5	Height $\geq 2'$ , but Jumping Height $\leq 2'$ at some flows
37	Beaver Dam #4	Height $\geq 2'$ , but Jumping Height $\leq 2'$ at some flows
38	Refuge Low Flow Crossing	Height $\geq 2'$ , but Jumping Height $\leq 2'$ at some flows
39	Beaver Dam #3	Height $\geq 2'$ , but Jumping Height $\leq 2'$ at some flows
40	Beaver Dam #2	Height $\geq 2'$ , but Jumping Height $\leq 2'$ at some flows
41	Beaver Dam #1	Height $\geq 2'$ , but Jumping Height $\leq 2'$ at some flows
51	Dan McNamara Road	Height $\geq 2'$ , culvert
69	Rock Weir	Height $\geq 2'$ , but Jumping Height $\leq 2'$ at some flows

**Table 7**  
Ranking Evaluation for Red

Identification Number	Description	Criteria Attribute
1	Friant Dam	Height $\geq$ 2', gated
21	San Joaquin River Bifurcation	Outlet Drop $\geq$ 2', gated with trash rack
22	Chowchilla Bifurcation	Outlet Drop $\geq$ 2', gated
26	Sack Dam	Plans for passage improvements
28	San Joaquin River Reach 4B Headgates	Culverts, gated
35	Mariposa Bypass control structure and drop structure	Height $\geq$ 2'
48	Eastside Bypass Bifurcation	Outlet Drop $\geq$ 2', gated
49	Mariposa Bypass Bifurcation	Outlet Drop $\geq$ 2', gated

## CONCLUSION

This document described the initial evaluation—deemed First Pass—to determine whether structures could be initially identified as a fish passage barrier that impede migration of juvenile and adult salmon and other native fish within the San Joaquin River restoration area. This analysis included a list of structures in the river that have the potential to be barriers to fish migration, initial criteria to identify potential fish passage barriers, development of the procedures and protocols for the First Pass surveys and a field inventory data sheet, and results of the First Pass evaluation. The result of the analysis was an identification of each structure as green, gray, or red, to signify whether it is likely a barrier to fish migration.

This First Pass evaluation is only an initial evaluation for many of these structures and is not intended to gather all the information for hydraulic modeling. After the First Pass evaluation, structures that are considered as Gray and Red will require additional evaluation under Task 2 and Task 3 of the San Joaquin River Restoration Program's Fish Passage Evaluation. Task 2 will include the evaluation and collection of additional information on the structure to develop hydraulic models; Task 3 will evaluate alternative designs to improve the passage characteristics of a structure. Those locations that are categorized as Green will no longer be evaluated and are not considered a fish passage barrier to fish at all life stages.

At the completion of these analyses, it is expected that a priority list of structures to replace or modify will be developed with coordination between fisheries experts to identify preliminary passage capability, and engineering expertise to measure and describe the barriers. These priorities will then be recommended to the SJRRP for inclusion as a Paragraph 12 action in the Settlement.

## REFERENCES

- Baker, C. O., F. E. Votapka, 1990. *Fish Passage Through Culverts*. Federal Highways Administration & USDA Forest Service. FHWA-FL-90-006. San Dimas, California.
- California Department of Fish and Game (DFG), 2002. *Culvert Criteria for Fish Passage*.
- California Department of Fish and Game (DFG), 1998. *California Salmonid Stream Habitat Restoration Manual. Third Edition*. DFG, Inland Fisheries Division.
- California Department of Water Resources (DWR), 2007. *Calaveras River Fish Migration Barriers Assessment Report*. DWR, Division of Planning & Local Assistance, Sacramento, California.
- California Department of Water Resources (DWR), 2005. *Bulletin 250, Fish Passage Improvement*. DWR, Sacramento, California.
- Federal Highway Administration (FHA), 2007. *Design for Fish Passage at Roadway-Stream Crossings: Synthesis Report*. United States Department of Transportation, FHA, McLean, Virginia.
- Jones & Stokes, 2001. *Technical Memorandum on the Potential Barriers to Migrating Steelhead and Chinook Salmon on the San Joaquin River*. Sacramento, California. (Prepared for Friant Water Users Authority and Natural Resources Defense Council).
- McBain & Trush, Inc. (eds.), 2002. *San Joaquin River Restoration Study Background Report*. (Prepared for Friant Water Users Authority and Natural Resources Defense Council).
- National Marine Fisheries Service (NMFS), 2008. *Anadromous Salmonid Passage Facility Design*. NMFS, Northwest Region, Portland, Oregon.
- NMFS, 2001. *Guidelines for Salmonid Passage at Stream Crossings*. NMFS, Southwest Region
- NMFS, 2000. *Guidelines for Salmonid Passage at Stream Crossings*. NMFS, Southwest Region
- Powers, P. D. and J. F. Orsborn, 1985. *Analysis of Barriers to Upstream Fish Migration, An Investigation of the Physical and Biological Conditions Affecting Fish Passage Success at Culverts and Waterfalls*. Final Report, Part 4 of 4. Department of Civil and Environmental Engineering, Washington State University.
- RBF Consulting, 2008. Preliminary Aerial Photography taken from San Joaquin River LiDAR Surveys. Prepared for the Department of Water Resources.
- Robison, E. G., A. Mirati & M. Allen, 1999. *Oregon Road/Stream Crossing Restoration Guide*. Oregon Department of Fish and Wildlife.
- San Joaquin River Restoration Program (SJRRP) Fisheries Management Work Group (FMWG). 2010. Fisheries Management Plan: A Framework for Adaptive Management in the San Joaquin River Restoration Program. November 2010.

Taylor, R. N. & M. Love, 2003. *Part IX, Fish Passage Evaluation at Stream Crossings, California Salmonid Stream Habitat Restoration Manual*. California Department of Fish and Game.

United States Army Corps of Engineers, 2005. HEC-RAS, River Analysis System, Version 3.1.3, Hydrologic Engineering center, Davis, California.

United States Forest Service (USFS), 2005. *National Inventory and Assessment Procedure – For Identifying Barriers to Aquatic Organism Passage at Road-Stream Crossings*. Transportation Management, USFS, San Dimas, California.

University of Wisconsin. *Fish Friendly Culverts*. University of Wisconsin-Extension in cooperation with the Wisconsin Department of Natural Resources.

Washington Department of Fish and Wildlife, 2000. *Fish Passage Barrier and Surface Water Diversion, Screening Assessment and Prioritization Manual*. Habitat Program, Environmental Restoration Division.

Washington Department of Fish and Wildlife, 2003. *Design of Road Culverts for Fish Passage*.

*[This page has been intentionally left blank]*

## **APPENDIX A**



*[This page has been intentionally left blank]*

Previously Identified Potential Barriers to Migrating Fish Species within the Project Area

River Mile Identification Number	Potential Barrier	Description	Identified By
Mainstem of San Joaquin River (SJR)			
267.5	Friant Dam	Upper limit of potential salmonid migration	McBain & Trush 2002
262.3	Road crossing		DWR 2005
258.5	Vulcan culverts	10 culverts under road; culverts blow out at high flows	Jones & Stokes 2001, DWR 2005
257.8	Irrigation Diversion		DWR 2005
253.4	Road crossing		DWR 2005
253	Culverts/Road crossing	Culverts between gravel-mining ponds	McBain & Trush 2002, DWR 2005
254.5-252.0	Pits	13 gravel mining pits	DWR 2005
248	Pits	4 gravel mining pits	DWR 2005
246.6	Pit		DWR 2005
243.1	Road crossing	Highway 99	DWR 2005
245.5-240	Pits	14 gravel mining pits	DWR 2005
240.7	Road crossing		DWR 2005
229.0	Stuart/Nees Road culverts	2 culverts between the gravel mining ponds in Reach 1	Jones & Stokes 2001
227	Earthen Dam	Earthen diversion dam just downstream of Gravelly Ford	McBain & Trush 2002
216.1	Chowchilla Bifurcation Dam	2 similar dams with radial gates	Jones & Stokes 2001, McBain & Trush 2002, DWR 2005
215.0	Lone Willow Slough control structure	Culverts with 4 slide gates on the upper end of Lone Willow Slough	Jones & Stokes 2001
211.8	San Mateo Avenue crossing	Concrete ford and culvert over the bed of the SJR downstream of Chowchilla Bifurcation Dam	Jones & Stokes 2001
206.0	Diversion	Columbia Canal	DWR 2005
205	Diversions	Several diversions in the Mendota Pool	DWR 2005
204.7	Mendota Dam and Reservoir	Low-head dam; pool backs up into the SJR channel for about 2–3 miles east of the Dam; barrier to fish passage even though a fish ladder is present; the effectiveness of the ladder needs to be determined	Jones & Stokes 2001, McBain & Trush 2002, DWR 2005
182.0	Sack Dam	Low-head earth and concrete dam with boards	Jones & Stokes 2001, McBain & Trush 2002, DWR 2005
168.5	Sand Slough control structure	Weir with slide gates; diverts all or most of SJR flow back into the Eastside Bypass system near Sand Slough	Jones & Stokes 2001, McBain & Trush 2002, DWR 2005

163.1 153.4	Farm Road crossing	2 road crossings with culverts just downstream of farm road crossing; culverts blow out at high flows	Jones & Stokes 2001
118.3	Merced River barrier	Temporary adult fish barrier just upstream of the confluence with the Merced River	Jones & Stokes 2001, McBain & Trush 2002
Bypass System Barriers (in addition to the bifurcation dam)			
168.5	Eastside Bypass control structure and drop structures	Drop structure near the confluence with SJR and Sand Slough	Jones & Stokes 2001, McBain & Trush 2002, DWR 2005
148.0		Dam with radial gates and drop structure, plus 2 additional drop structures downstream of the confluence with SJR	
147.6	Mariposa Bypass control structure and drop structure	Dam with radial gates and drop structure downstream of the confluence with SJR and San Luis National Wildlife Refuge	Jones & Stokes 2001, McBain & Trush 2002, DWR 2005
138	Eastside Bypass drop structure	Drop structure near the confluence with SJR	McBain & Trush 2002

---

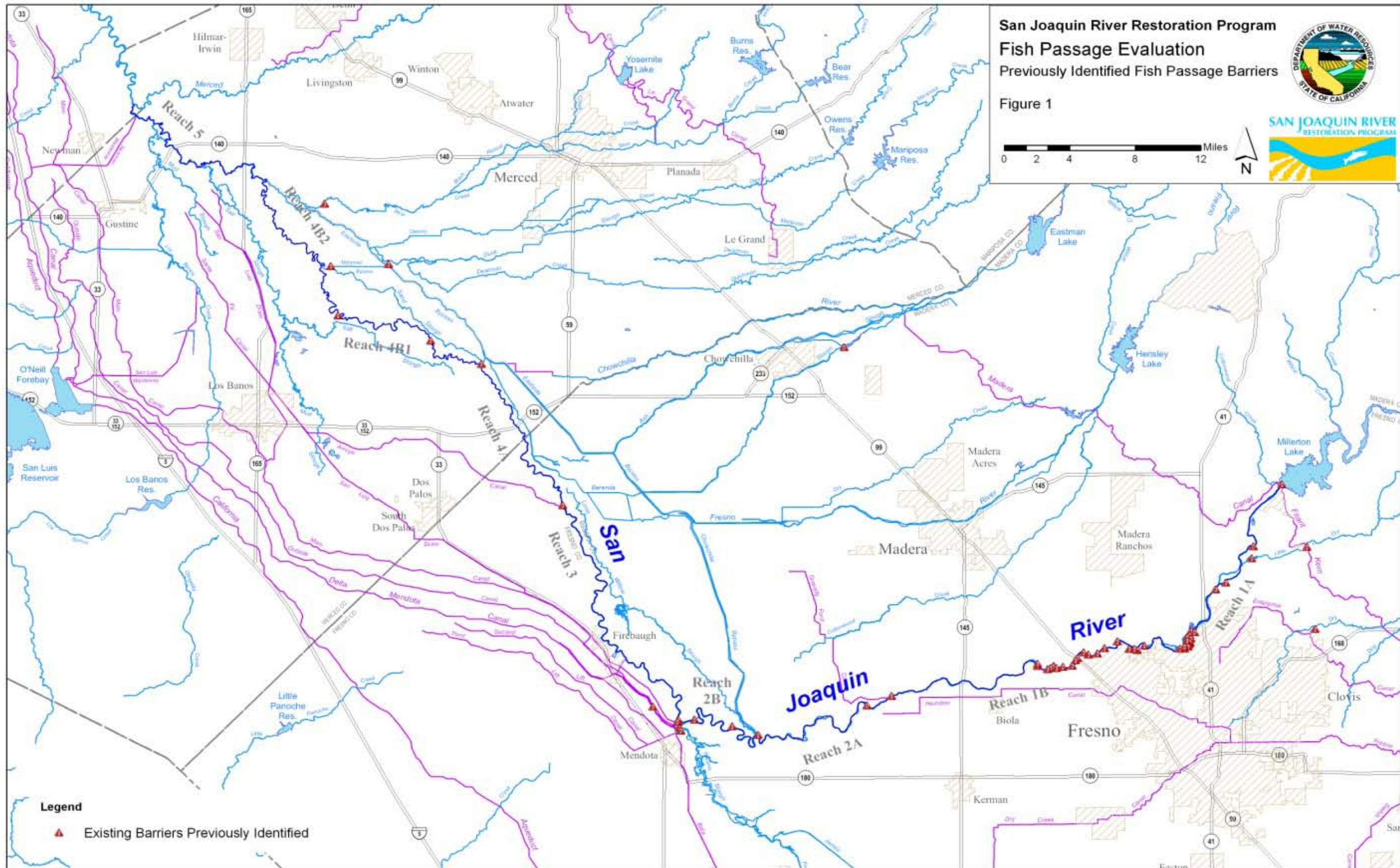

*[This page has been intentionally left blank*

## **APPENDIX B**

*[This page has been intentionally left blank]*

# FIRST PASS SURVEY PROTOCOL

This protocol was developed to provide guidance and clarification to field crew members or assessors on the First Pass data collection procedures and data collector entries for the San Joaquin River Restoration Program. The protocol was originally developed in 2002 for Caltrans' Fish Passage and Culvert Identification Programs to make sure that all field crews provide complete, accurate, and consistent information. A section on definitions and standard terminology is also included to improve data consistency.

## First Pass Assessment Preparation

### What to Survey

First pass assessments will be performed at all locations that were identified as potential barriers and those that have been previously identified as barriers. Bridges will also be surveyed, but on a more limited level. Only those sites within the public right of way (ROW) or those with a temporary entry permit (TEP) will be accessed. Expect to spend one to two hours surveying each site. Travel time to each site will vary.

### Field Crews

Crews must consist of at least two people and should be made up of an engineer and environmental scientist, if possible. Those with fisheries, hydrology/geomorphology and engineering surveying experience are preferred.

### Location of Stream Crossings

The Geodatabase report will include an initial assessment of the San Joaquin River and bypass system that will provide the potential locations for the first pass evaluation. The Geodatabase includes previously identified locations from other sources and those identified by the criteria. Before entering private lands, access permission must be obtained from all private landowners. *TEPs may or may not be needed, contact Craig Moyle with final locations of potential barriers for any structures that are not within the public ROW.*

### Site Visit

A site visit is conducted to collect physical measurements that will determine the extent of fish passage. This information will be recorded on the Fish Passage Inventory Data Sheet. Additional information that will be collected includes:

- A description of the type and condition of each location
- Qualitative comments describing stream habitat immediately above and below each location
- GPS waypoints
- Site sketch and photographs
- At some locations a flow measurement

### Field Preparation

Prior to conducting field inventories all permits that may be required to legally work at each location need to be obtained and provided to field staff. Always obtain landowner permission before accessing private property. All staff should use proper safety equipment and assess the site-specific characteristics of each location before conducting longitudinal surveys. Staff should be properly trained and a safety meeting should be performed each day of field work.



Use extreme caution when entering into or wading through all structures. No entry into structures that are defined as confined spaces (see field sheet for criteria) without proper training and safety equipment. Field staff should always wear a hard hat (chin strap recommended), protective footwear, and carry a flashlight during surveys. Crews should be equipped with two-way radios that are approved by the Department and provide for contact for emergency services.

Prior to conducting field inventories, the following equipment and supplies should be assembled:

#### Safety Equipment

- |  |   |
|--|---|
| <input type="checkbox"/> Hard Hat (with chin strap)          | <input type="checkbox"/> PFD's (Personal Flotation Devices) in duffel |
| <input type="checkbox"/> Safety Vest                         | <input type="checkbox"/> Rotating safety light for vehicle            |
| <input type="checkbox"/> Emergency Contacts list (hospitals) | <input type="checkbox"/> Fire Extinguisher                            |
| <input type="checkbox"/> Safety Manual                       |   |
| <input type="checkbox"/> Signs, and cones (if near traffic)  |   |

#### Personal Safety Equipment

- |  |   |
|--|---|
| <input type="checkbox"/> Hat                   | <input type="checkbox"/> Sunglasses                       |
| <input type="checkbox"/> Work Boots with grips | <input type="checkbox"/> Gloves                           |
| <input type="checkbox"/> Chest Waders          | <input type="checkbox"/> Cell Phone, battery, car charger |
| <input type="checkbox"/> Rain gear             | <input type="checkbox"/> Sunscreen                        |
| <input type="checkbox"/> Drinking Water        | <input type="checkbox"/> Snacks                           |

#### Field Equipment

- |   |  |
|---|--|
| <input type="checkbox"/> Black Marking Pens                                   | <input type="checkbox"/> Insect repellent  |
| <input type="checkbox"/> Pencils/Pens   | <input type="checkbox"/> First Aid Kit   |
| <input type="checkbox"/> Flashlight   | <input type="checkbox"/> Machete/Loppers   |
| <input type="checkbox"/> Clip Board w/graph paper                             | <input type="checkbox"/> Clippers  |
| <input type="checkbox"/> Maps (marked with site locations)                    | <input type="checkbox"/> Tape Measures (300', 100', & 25')   |
| <input type="checkbox"/> Spare batteries (AA & D)                             | <input type="checkbox"/> Clamps to secure tapes  |
| <input type="checkbox"/> Trimble GPS  | <input type="checkbox"/> Pocket Level  |
| <input type="checkbox"/> Camera w/charger                                     | <input type="checkbox"/> Two way radios & spare batteries  |
| <input type="checkbox"/> Tape (masking, scotch, duct)                         | <input type="checkbox"/> Paper for site sketches   |
| <input type="checkbox"/> Binoculars (optional)                                | <input type="checkbox"/> USGS Quad maps of route   |
| <input type="checkbox"/> Clinometer   | <input type="checkbox"/> Names and phone numbers of property owners, along with copies of access agreement |
| <input type="checkbox"/> Data collection sheets, printed on water-proof paper |  |

#### Other Personal & Miscellaneous Items

- |  |   |
|--|---|
| <input type="checkbox"/> Ice chest, food & drink | <input type="checkbox"/> Hand wipes/waterless sanitizer |
|--|---|

Note:

Crew members are expected to report to work reasonably dressed to protect themselves during routine assignments and from exposure to usual and/or predictable physical and environmental conditions found at the work site.

## First Pass Data Collection Entry

This section is to provide some guidance and clarification to field crew members on the data collector entries for the Fish Passage Inventory Data Sheet.

Please fill in every field (exceptions are noted). If a field is left blank we don't know if it was overlooked, blank fields make trouble for database queries, and it may require a re-inspection of the site. All attributes in the data collector feature should be completely filled out unless there are access issues that prevent this.

The following text explains the data collector attributes. Attributes are indicated in **bold type** and the clarifying text is plain type.

**Date; Time.** These fields are automatically collected by the Trimble unit.

**Agency; Data Recorder; Survey Team.** These are required fields. The data collector will not let you proceed until you fill in these fields. This data lets us know where the site is, and who to talk to if there is data missing or unclear entries.

**GPS point taken.** Take the GPS point at the inlet or outlet of the structure, try to take it at the site but if no satellites are available due to poor reception, lack of access, etc. find the nearest location and note it in the distance from the site attribute.

**Distance from Site.** Include an estimate of the horizontal distance from the GPS location to the inlet or outlet. If the reading was taken at the inlet or outlet, type "0".

**Latitude/Longitude:** This information is pulled from the first pass data sheet and is based on the pre-survey location.

**GPS Brand.** The current data collector is a GeoExplorer XH, but change the field if it is different than the default.

**River mile.** The following methods can be used to estimate river mile:

1. Use the river mile provided for the site from the first pass site inventory list.
2. Use the USGS quadrangular map with DWR river miles to locate the nearest river mile, estimate to the nearest 0.1 mile. (Use the DWR river miles over the USGS river miles.)
3. Use GPS to estimate the river mile. (Take a point at a known river mile, get a reading at the new location; GPS calculates the distance between points)

**Crossing type.** This is a required field.

**Crossing type (Culvert).** A culvert is a structure with a hard bottom.

**Crossing type (Bridge).** Typically, bridges are structures that have a sufficient width and invert characteristic that will not obstruct fish passage. Piers that are more than 20 feet apart, have a natural bottom, and provide little obstruction to the channel can be considered a bridge. Unless it has a hard bottom or other obstruction to fish passage, in which case it should be marked as a culvert.

**Crossing type (Weir/Low Flow Crossing).** An obstruction where flow occurs through or over. If it has culverts, in addition mark it as a culvert.

**Crossing type (Control Structure).** A structure that has a manual or automatic control (typically a gate) that can completely block flow from entering the channel. If it is controlling flow from entering the SJR this would not be surveyed but photos and a site sketch should be completed.

**Crossing type (Natural Barrier).** Typically landslides, waterfalls, boulder cascades, etc. or anything that is not man-made will fall under this category.

**Crossing type (Other/Comment).** If other, describe the type of stream crossing in the comment field.

Land Ownership information is necessary to provide access requirements for the Second Pass surveys. The Second Pass surveys will likely require cross-sections downstream to the tailwater control and upstream to show the natural channel characteristics. The inputs should describe the current Temporary Entry Permits (Rights of Entry), if access is available with heavy survey equipment, and if vegetation removal will be required.

**Temporary Entry Permit Obtained?** If there is a TEP required for access, enter the permit information and have a copy of the permit while visiting the site.

**Accessibility Limitations.** If the site is not accessible, note the reason for the lack of access (steep terrain, vegetation, fences, etc.). If the site is accessible enter “n/a”. This information will be needed to determine whether temporary entry permits, vegetation clearing, or boats is needed to access the culvert for First Pass and Second Pass surveys. Provide any details specific to the site in the comment field.

**Vegetation Removal.** Is major vegetation removal required to access the site? Can you get your second pass equipment down to the site?

**Confined Space Screening.** These fields are necessary to determine if the structure may be considered a confined space. If the answer is no to any of the following questions, **do not enter the confined space during First Pass surveys.** Special equipment and trained staff will be needed for Second Pass survey.

**Culvert dia. >60”.** Is the culvert greater than 5 feet high?

**See Daylit thru Culv.** Can you see daylight through the culvert?

**Breeze thru Culvert.** Can you feel a breeze through the culvert?

**Stream Flow Cond.** What is the stream’s flow condition? Drop down menu.

**Wet.** Stream bed is wet and water is flowing.

**Dry.** No water in the stream bed

**Discontinuous.** Pools of water separated by dry portions of stream bed. Water may be flowing through the stream bed gravel, but there isn’t surface water connecting the pools.

**Fish Presence.** Fish observed during 1<sup>st</sup> pass survey? Drop down menu.

**Observation Summary.** Provide a text observation summary of fish presence. If no fish observed, enter n/a.

**Channel Details.** Fill in the observed percentage of channel substrate by soil type (should total 100%). Drop down menu to choose the channel vegetation to determine an estimate of the channel roughness. Note the downstream channel characteristics for hydraulic controls or that would create a potential barrier for fish passage.

**Downstream/Upstream Barrier.** Is there a barrier observable from the site or known to exist in the vicinity? Drop down menu of choices.

**Distance (ft.) to TR.** What is the distance between the trash rack and the inlet?

**Trash Rack @ Site.** Is there a trash rack present at the site? It would be on the upstream/inlet side. If none, the next 4 fields can be left blank.

**Bridge Dimensions:** The height is measured from the channel bottom to the bottom of the bridge deck. The width is measured as the area that is open over the channel between bridge abutments is compared to channel width. Length is defined as the sum of the apron length and the riprap length along the channel. Drop should be measured when either an apron or riprap is present.

**Active Channel Width:** This is the same as the ordinary high water level and is determined by scoured substrate of the channel and terrestrial vegetation begins, natural line impressed on the bank, shelving or terracing, changes in soil character, etc. The active channel width is less than a bankfull channel width. Measure the channel width upstream the site outside of the influence of the barrier. Choose a location where the width appears to be typical of the reach.

**# of Bridge Piers:** Total the number of bridge piers.

**Distance between piers:** Measure the distance between the bridge piers.

**Is there a hydraulic jump present?** Is there a hydraulic jump or a noticeable difference in water surface elevation upstream or downstream the bridge?

**Apron and/or Riprap scour protection?** Is there an apron and/or Riprap scour protection in channel under the bridge that would interfere with fish passage?

**Is it submerged?** Yes or No.

If the site is a bridge and there is not a hardened bottom, stop there and skip ahead to the photographs and site sketch/description portion of the inventory data sheet.

**Natural Barrier Description.** Select the most appropriate description.

Ford – an area that is shallow enough to be crossed by wading, on horseback, or in a wheeled vehicle. A ford is mostly a natural phenomenon, in contrast to a low water crossing, which is an artificial bridge that allows crossing a river or stream when water is low.

Chute (flume, race, or river canyon) –passage through which water flows rapidly.

Dams or Debris Jams – form lakes, ponds, and wetlands behind the wall of vegetation that has become a barrier to flow downstream. These will naturally leak so a small amount of flow should be seen downstream.

Waterfall – flowing water rapidly drops in elevation as it flows over a steep region, a cliff, or cascade.

**Natural Barrier Height.** The height of the ford from the adjacent level channel bottom to the top. Measure the upstream and the downstream height and use the highest value. The height of the chute or falls from the crest to the plunge pool. A dam or debris jam height is measured from the base at the channel bottom to the upstream and the downstream highest value. A value of zero is the same elevation as the channel bottom.

**Natural Barrier Length.** The length of the ford. The length of the chute, measured from the distance of the upstream pool to the crest of the falls or end of the chute at the downstream pool. Dams or Debris Jams length is the total length of material blocking the channel at its maximum. The length of the falls is measured from the crest of the falls to the end of the drop at the base of the cliff or cascade.

**Natural Barrier Material.** What is the material of the barrier?

**Can it be bypassed?** Can migrating fish bypass the potential natural barrier?

**Max. Pool Depth Downstream.** The depth of the deepest part of the plunge pool downstream the barrier.

**Max. Pool Distance.** The distance from the deepest part of the plunge pool to the upstream pool just beyond the barrier crest.

**Gate Description.** What is the type of gate on the structure?

Radial Gate. A structure, where a small part of a cylindrical surface serves as the gate, supported by radial constructions going through the cylinder's radius.

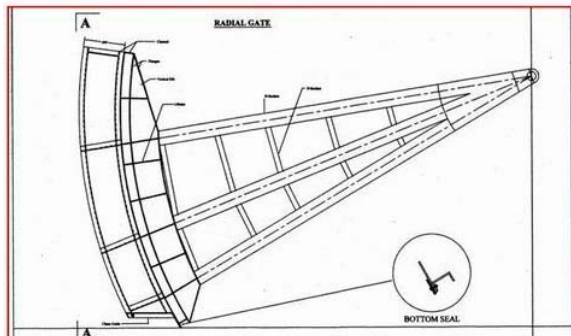

Slide Gate. A plate sliding in the vertical direction.

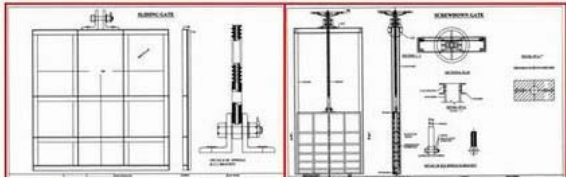

Flap Gate. A fully automatic type, which is controlled by the pressure head across it; operation is similar to a check valve. It is a gate hinged at the top.

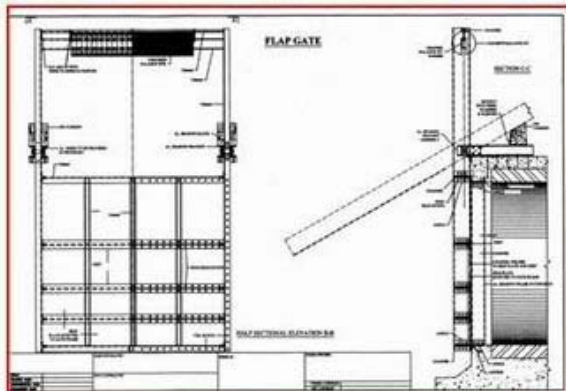

Tilting Gate. A plate that tilts on a hinge.

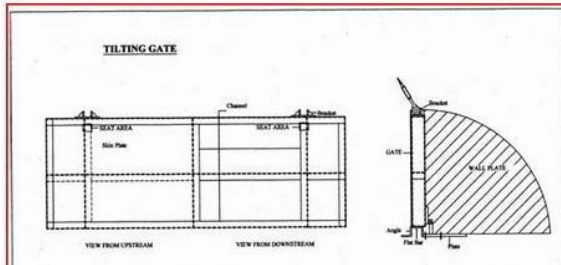

**Total # of Openings.** If there are multiple openings they need to be totaled and the opening dimension needs to be measured. If there are multiple openings with different dimensions than a new sheet needs to be filled out with the data.

**Height/Width:** The height and width of the control structure openings.

**Max. Height of Openings from channel bottom.** Measure the distance from the bottom of the gate opening to the adjacent channel bottom. For multiple openings, measure all openings and note the maximum height.

**Structure Dimensions.** The measurement of the height is from the channel bottom to the top of the structure wall or gate (whichever is greater). The width would include any apron and/or rip rap. The total length of the structure from the left bank to the right bank. Drop will be measured from the downstream edge of the structure to the channel bottom.

**Can it be bypassed?** Can migrating fish bypass the potential natural barrier?

**Fish Ladder.** Is there a fish ladder present? Yes/No

**Maximum Pool Depth Downstream.** Survey the maximum pool depth for the staging pool downstream the weir, but within 5 feet of the weir. If no water is present at the time, the height can be estimated to the top of soil adjacent the weir or that of the end of the staging pool downstream (creating backwatering of the pool). The landing pool distance upstream the weir needs to be measured at the first point when the depth reaches one foot.

**Maximum Pool Depth.** Survey the maximum pool depth for the staging pool downstream the structure, but within 5 feet. If no water is present at the time, the height can be estimated to the top of soil adjacent the weir or that of the end of the staging pool downstream (creating backwatering of the pool).

**Maximum Pool Distance.** The landing pool distance upstream the structure needs to be measured at the first point when the depth reaches one foot.

**Dam Name:** If known, please fill in the name of the dam.

**Dam Dimensions:** The height is measure from the dam crest to the channel bottom. The width is measured from the opening between abutments.

**Bankfull Channel Width:** The maximum channel width before leaving the channel to enter the floodplain. May be noted by changes in vegetation, shelving or terracing, presence of deposited organic debris and litter, etc.

**Drop from dam base to channel bed/apron:** Drop will be measured from the downstream edge of the dam base to the channel bottom or apron.

**Apron and/or Riprap scour protection?** Is there an apron and/or Riprap scour protection in channel under the bridge that would interfere with fish passage?

**Is it submerged?** Yes or No.

**Fish Ladder.** Is there a fish ladder present? Yes/No

**Dam control description:** A description of the hydraulics of the dam and how it affects the function of the channel and could influence fish passage. Note the hydraulic features especially any control features, like flashboards, etc.

**Maximum Pool Depth.** Survey the maximum pool depth for the staging pool downstream the weir, but within 5 feet of the weir. If no water is present at the time, the height can be estimated to the top of soil adjacent the weir or that of the end of the staging pool downstream (creating backwatering of the pool).

**Maximum Pool Distance.** The landing pool distance upstream the weir needs to be measured at the first point when the depth reaches one foot.

**Weir #.** The number of the segment being evaluated. Number from upstream to downstream starting with “1”  
**Opening #.** The number of the weirs being evaluated. Number from the left bank to the right bank (determined when facing downstream) starting with “1”.

**Weir Type.** What type of weir?

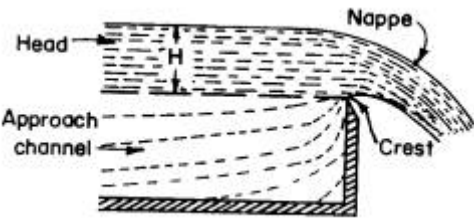
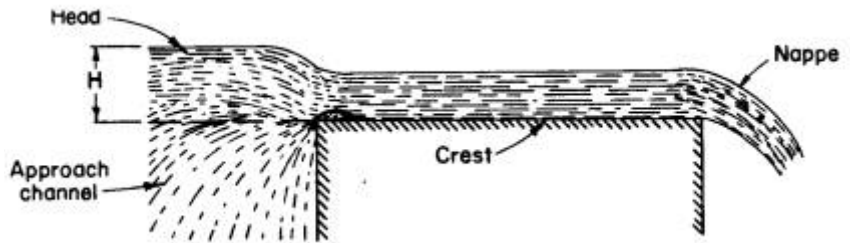
<p><b>Sharp-crested.</b> The crests are constructed of thin metal plates or wood.</p>	
<p><b>Broad-crested.</b> The crests are made of wide timber or concrete.</p>	



**Weir Shape.** What is the shape of the weir?

**Rectangular.**

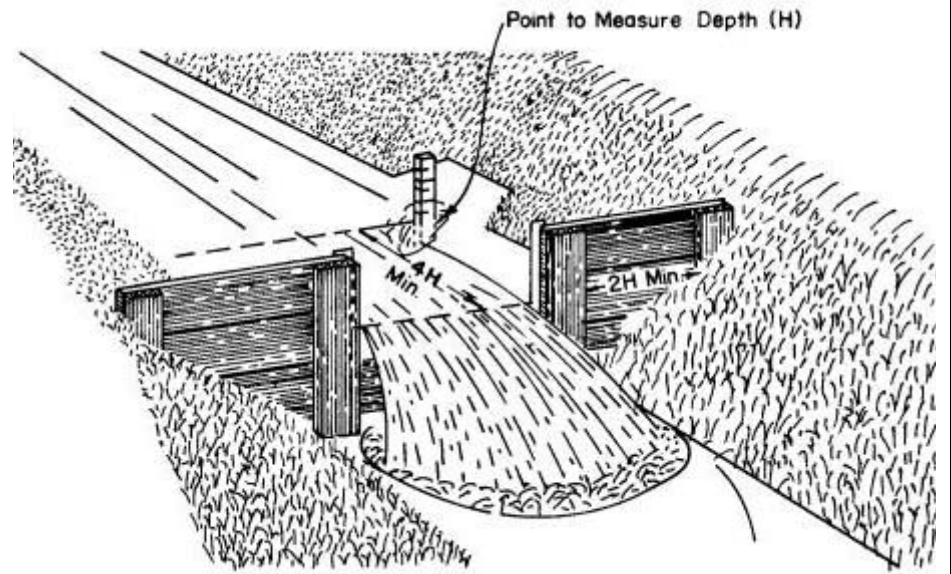

**Trapezoidal.**

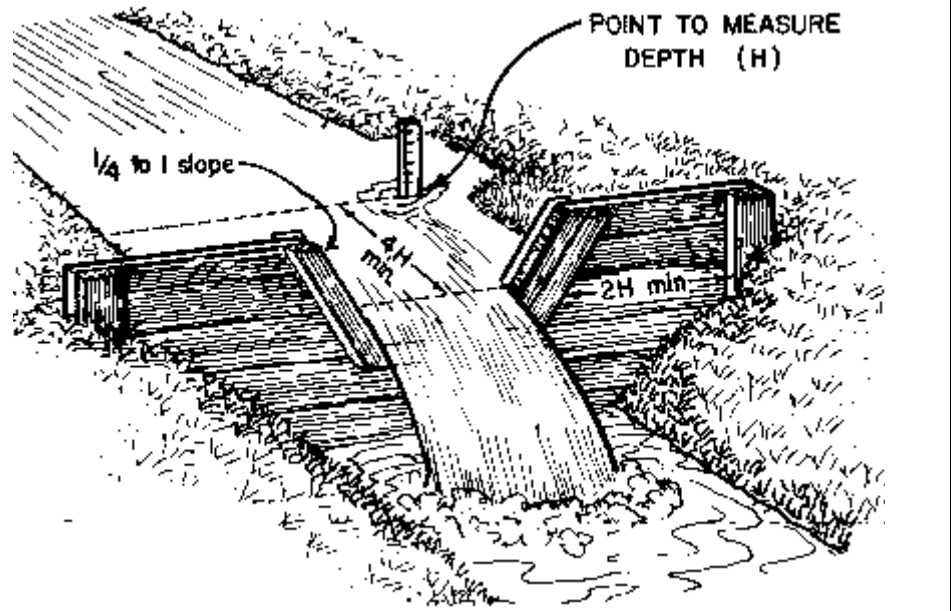

**Triangular.** V-notched weirs shaped like a triangle.

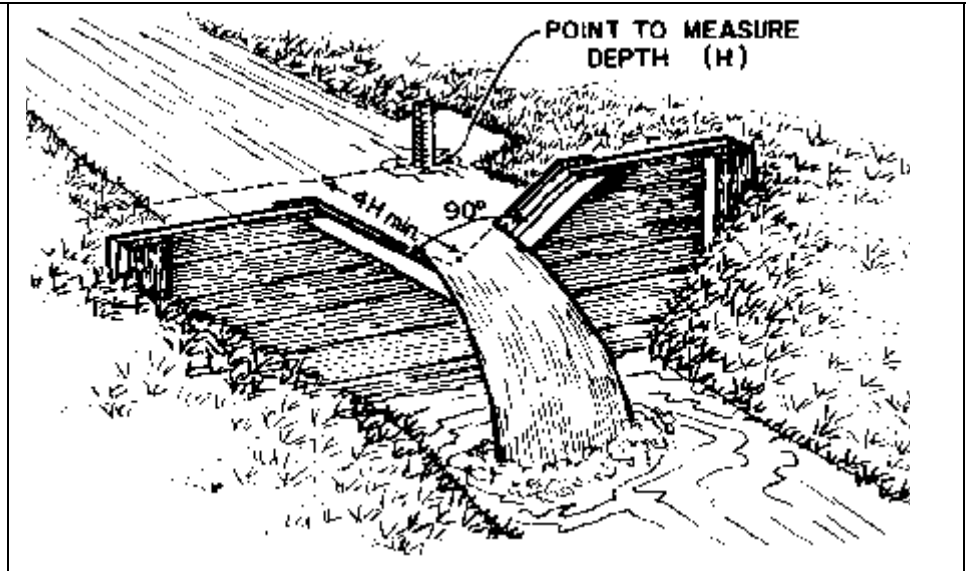

**Weir Dimensions.** Fill in the height/rise, width/span, and length of the weir in feet. Height/Rise is from water surface to the highest point of the opening or barrier. The height is measured from the weir crest to the channel bottom.

**Weir Description.** Describe any uniqueness

**Is it submerged.** Is the weir submerged? Yes/No

**Total # of Openings.** Depending on the type of weir, if there are multiple openings they need to be totaled and the opening dimension needs to be measured. If there are multiple openings with different dimensions than a new sheet needs to be filled out with the data for weir # and opening #.

**Maximum Pool Depth.** Survey the maximum pool depth for the staging pool downstream the weir, but within 5 feet of the weir. If no water is present at the time, the height can be estimated to the top of soil adjacent the weir or that of the end of the staging pool downstream (creating backwatering of the pool).

**Maximum Pool Distance.** The landing pool distance upstream the weir needs to be measured at the first point when the depth reaches one foot.

**Fish Ladder.** Is there a fish ladder present? Yes/No

**Concrete Apron or Rip Rap.** Is there a concrete apron or rip rap downstream of the weir that could potentially impede the fish passage? Yes/No

**Structure Name:** Road name or crossing name if known.

**Low Flow Crossing Dimensions:** The structure height will be measured from the downstream edge of the structure to the channel bottom. Length is defined as the distance between the upstream and downstream edges of the crossing plus the riprap length. Width is measured at the crest length between the channel banks.

**Bankfull Channel Width:**

**Drop from base to channel bed/apron:**

**Apron and/or Riprap scour protection?** Is there an apron and/or Riprap scour protection in channel under the bridge that would interfere with fish passage?

**Is it submerged?** Yes or No.

**Fish Ladder.** Is there a fish ladder present? Yes/No

**Crossing description:** A description of how the crossing influences the hydraulics of the channel and how the crossing could affect fish passage, include any details like if it is a vented ford with culverts, etc.

If there are culverts present, (i.e. a vented ford), then continue to complete the culvert section.

**Photographs.** Photographs should focus on the potential barrier and the river upstream and downstream. Additional photographs would include items like rip rap, ground breaks, trash racks, fish ladders, falls, or any other potential barriers that exist at the site.

The first picture of the photo series should be a picture of the river mile at the site. Write down the approximate river mile on a piece of paper (large, bold characters) and photograph it prior to photographing the site. Photos should include the following:

Site ID (handwritten sign)

Upstream side of the barrier looking upstream

Upstream side of the barrier looking downstream

Downstream side of the barrier looking upstream

Downstream side of the barrier looking downstream

Other site features of note (examples include poor condition, weirs, baffles, fish ladders, segment breaks, failing road fills, debris plugs at inlet, etc.)

At bridge sites the following photographs are required:

Site ID (postmile marker)

Upstream side of the bridge looking upstream

Downstream side of the bridge looking downstream

**Site Sketch.** The site sketch will help to evaluate the channel alignment and interpreting survey results. Draw the map approximately to scale and illustrate the spatial relationship of the channel and flood plain features and

their relation to the potential barrier. Note any key features, such as cross sections and bankfull elevations to ensure their inclusion in the topographic survey.

Make a sketch of notable features of the culvert site. Include dimensions, materials, and notes on the sketch. Try to capture features that aren't obvious from the photos or collected data. The more detail the better. The site sketch will be used to assist modelers when entering information in FishXing and when deciphering survey data.

Example of a Site Sketch (Taylor, R. N. & M. Love, 2003)

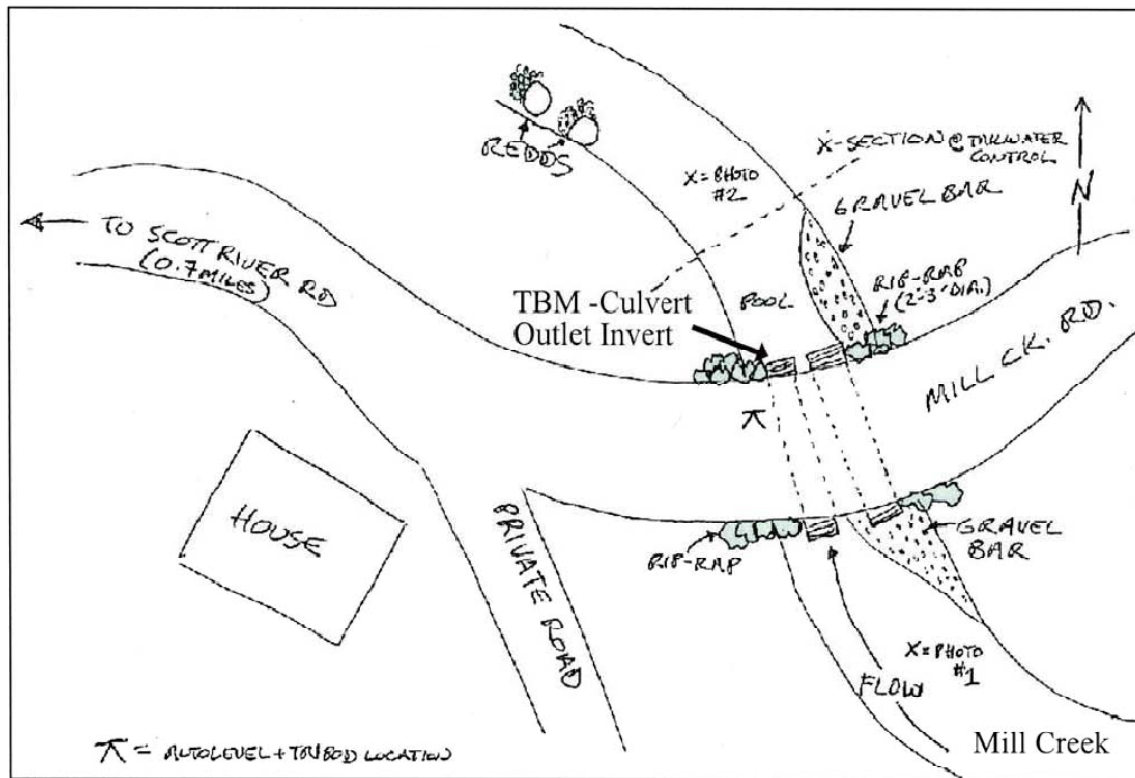

**Site Description.** Describe unique features of the site.

**Culvert #.** The number of the culvert being evaluated. Number from the left bank to the right bank (determined when facing downstream) starting with "1".

**Culvert Total.** How many culverts at the site?

**Segment #.** The number of the segments being evaluated. Number from upstream to downstream starting with "1"

**Segment Total.** How many segments make up the culvert? Segments begin and end at changes in culvert material, shape, and dimensions. Breaks in the culvert slope or changes in direction should be counted as different segments.

**Segment Shape.** What is the shape of the segment being evaluated? Drop down menu.

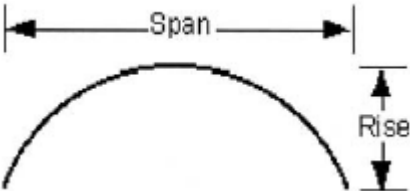
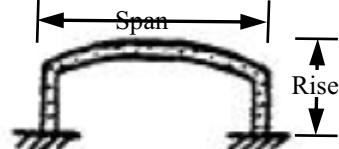
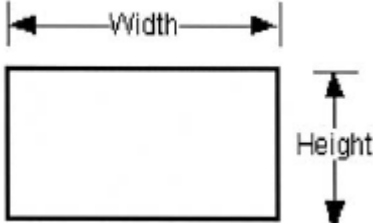
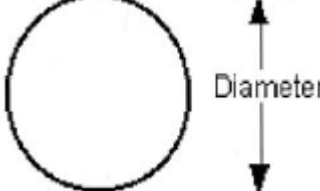
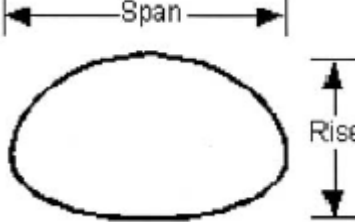
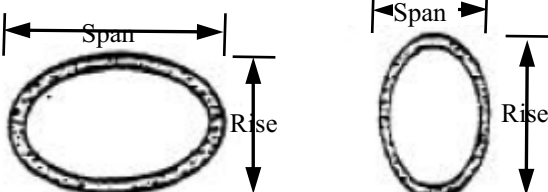
<b>Arch</b>	
<b>Arch-Top Box</b>	
<b>Box</b>	
<b>Circular pipe</b>	
<b>Pipe-arch</b>	
<b>Elliptical pipe</b>	

**Seg. Diameter.** Measurement of round culvert segments. Leave blank for other shaped segments.

**Seg. Hght/Rise (ft.).** Vertical measurement at the greatest point of non-round culvert segments. Leave blank for circular segments.

**Seg. Wdth/Span (ft.).** Horizontal measurement at the greatest point of non-round culvert segments. Leave blank for circular segments.

**Seg. Length (ft.).** Length of the culvert segment, not including the apron. Leave blank if there is a confined space or other safety restriction.

**Seg. Description.** Describe any uniqueness in shape, such as widely varying conditions between segments, varying materials, slope, shapes, etc. Otherwise enter “n/a”.

**Rustline (ft.).** If present, measure the height (to nearest 0.1 ft) of the rustline peak inside metal culverts. Measure the rustline near the mid-length of the culvert, away from noticeable differences affected by the inlet, outlet, baffles, or weirs (see figure below). If no rustline is apparent (new steel pipe or made of concrete, aluminum, plastic, clay, etc.) enter “0”.

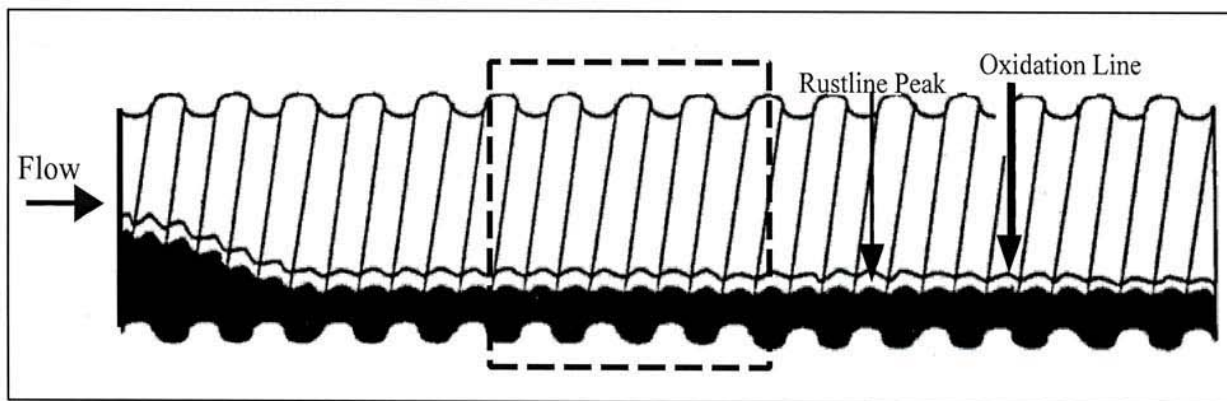

**US Segment End Type.** What is the upstream end of the culvert segment being evaluated? Drop down menu of choices.

**inlet.** The upstream end of the culvert segment is the inlet.

**cul. seg. connection.** The upstream end of the segment is a connection to another culvert segment (multiple segment culvert).

**discontinuous (gap).** There is a gap between culvert segments (multiple segment culvert).

**DS Segment End Type.** What is the downstream end of the culvert segment being evaluated? Drop down menu of choices.

**outlet.** The downstream end of the culvert segment is the outlet.

**cul. seg. connection.** The downstream end of the segment is a connection to another culvert segment (multiple segment culvert).

**discontinuous (gap).** There is a gap between culvert segments (multiple segment culvert).

**Cul. Connection Desc.** Enter comments about notable aspects of the segment and its connections to the upstream/downstream segments, if any. Otherwise enter “n/a”.

**Culvert Description.** Describe unique features of the culvert segment. If unremarkable, enter “n/a”.

**Segment Materials.** What is the culvert material? Drop down menu of choices.

<b>Ann (125 x 25mm)</b> <b>Ann (152 x 51mm)</b> <b>Ann (229 x 64mm)</b> <b>Ann (68 x 13mm)</b> <b>Ann (76 x 25mm)</b>	Metal culverts (round or pipe arch) with annular corrugations. See figures below for clarification of types and spacing of corrugations.
<b>Hel (125 x 25mm)</b> <b>Hel (152 x 51mm)</b> <b>Hel (229 x 64mm)</b> <b>Hel (68 x 13mm)</b> <b>Hel (76 x 25mm)</b>	Metal culverts (round or pipe arch) with helical corrugations. See figures below for clarification of types and spacing of corrugations.
<b>Cast Iron Pipe</b>	Black iron pipe. Generally small diameter.
<b>Clay Sewer Pipe</b>	It is clay; it will clink when you tap it.
<b>Comp Stl Spiral Rib</b>	Steel spiral ribbed pipe externally pre-coated with a polymeric sheet, and internally polyethylene lined
<b>Concrete</b>	Concrete culvert that isn't circular
<b>Conc Pipe (Cast)</b>	Circular cast-in-place concrete pipe. Look for evidence of rebar and casting forms.
<b>Conc Pipe (Pre-Cast)</b>	Circular pre-cast concrete pipe. Uniform size & shape; made in sections that can be easily transported, lifted, and installed.
<b>Plastic (Corr Intr.)</b> <b>Plastic (Smth Intr.)</b>	Plastic pipe with corrugated or smooth interior. Constructed of various types of high-impact plastics.
<b>Spiral Rib, 191mm oc</b> <b>Spiral Rib, 213mm oc</b> <b>Spiral Rib, 292mm oc</b>	Metal pipe with “rib” in a spiral orientation. See figures below for clarification of look and spacing of ribs.
<b>Steel Pipe, Ungalv.</b>	Ungalvanized steel pipe; likely rusty unless new.
<b>Struct. Plate</b>	Structural plate. Large corrugated culverts (usually circular or pipe arch) are normally field-assembled of multiple plates of corrugated galvanized steel, bolted together (look for the bolts). Standard plates have corrugations with a 150 mm (6-in) pitch and 50 mm (2-in) depth. See figures below for clarification of shapes and spacing of corrugations.
<b>Other</b>	Other materials not listed above.



**Segment Bottom.** What is the segment bottom or lining material? Some culverts are completely coated, while others just have the bottom treated. Drop down menu of choices. Same as the culvert segment material choices above, plus the following:

<b>Same as Segment</b>	There is no lining nor different segment bottom.
<b>Bitumous Coating</b>	Thin, black tarry coating on corrugated metal pipe
<b>Plastic</b>	Hard plastic coating on corrugated metal pipe. May also be a sleeve inserted into the culvert.
<b>Grouted Rock</b>	Rock cemented into place. Most likely in arch or concrete culverts
<b>Natural Substrate</b>	Natural streambed material. Most likely in bridges, arch culverts, and fully & deeply (more than a couple of inches) embedded pipes.

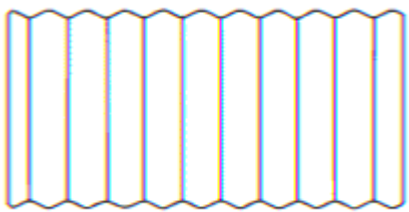
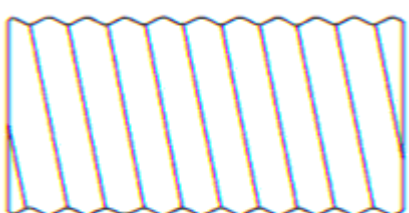
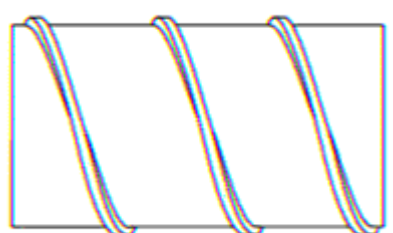
**Types of Corrugated and Ribbed Metal Pipe:**

<p><b>ANNULAR CMP</b> ANNULAR PIPE HAS CORRUGATIONS PERPENDICULAR TO THE CENTER LINE OF THE PIPE</p>	
<p><b>HELICAL CMP</b> HELICAL PIPE HAS SPIRAL CORRUGATIONS</p>	
<p><b>SPIRAL RIB PIPE</b> OUTSIDE RECTANGULAR HELICAL RIBBED PIPE</p>	

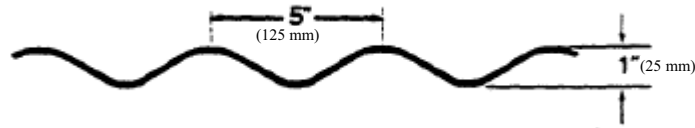
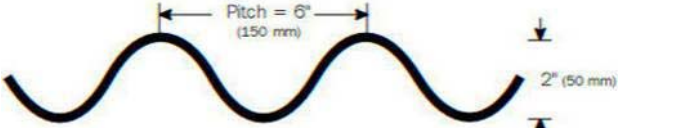
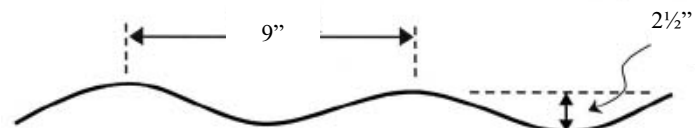
**Corrugated Metal Pipe spacing:**

<p>125 mm x 25 mm</p>	
<p>152 mm x 51 mm</p>	
<p>229 mm x 64 mm</p>	
<p>68 mm x 13 mm</p>	
<p>76 mm x 25 mm</p>	



Spiral Rib Metal Pipe spacing:	
19 mm (W) x 19 mm (D) @ 191 mm o/c	
19 mm (W) x 25 mm (D) @ 213 mm o/c	
19 mm (W) x 25 mm (D) @ 292 mm o/c	

### TYPICAL STRUCTURAL PLATE ARRANGEMENTS

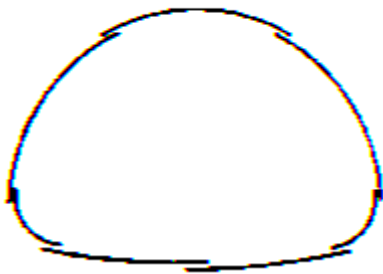

STRUCTURAL PLATE PIPE-ARCH

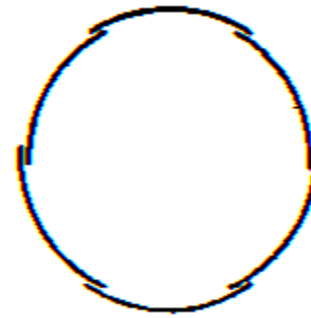

STRUCTURAL PLATE PIPE

**Seg Side Mat Cond.** Condition of segment side material and walls. Drop down menu of choices.

**Seg Side Cond. Desc.** Description of segment side condition. Enter comments about anything notable about the condition of the segment walls or “n/a”.

**Seg Botm Mat Cond.** Condition of segment bottom material. Drop down menu of choices.

**Seg Botm Cond. Desc.** Description of segment bottom condition. Enter comments about anything notable about the condition of the segment bottom or “n/a”.

**Seg Embedded.** Is the segment embedded in the stream channel? Is there streambed material inside the culvert? Does not apply to open arch culverts because they have no bottom (enter “no” in data collector). If “no”, leave next 5 fields blank.

**Embedded (Yes?).** If the culvert is embedded, fill in this field. Drop down menu.

**Partially.** The streambed material doesn’t cover the whole culvert bottom or doesn’t extend the entire length of the culvert.

**Fully.** The entire culvert bottom is covered with streambed material.

**Embeddness Lngt (ft).** Measure the length of the culvert that is embedded.

**Begin Depth (ft.).** Measure the depth of the streambed material at the upstream end of the embedded portion of the culvert. If the culvert is partially embedded, this value will be “0”.

**End Depth (ft.).** Measure the depth of the streambed material at the downstream end of the embedded portion of the culvert.

**Dominant Substrate.** What is the size of most of the embedding material? Drop down menu of choices.

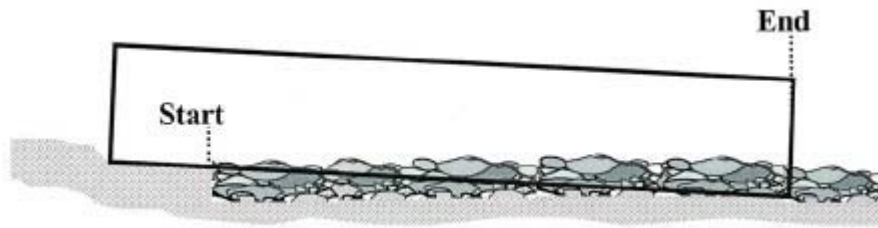

Partially Embedded Culvert

**Retrofit Type.** What kind of weirs or baffles been installed inside the culvert segment? Drop down menu of choices.

<b>None.</b> If so leave next field blank.			
<b>Corner Baffles</b>	<b>Notched Weirs</b>	<b>Offset Baffles</b>	<b>Ramp Baffles</b>

Gravel Retent Weirs.

**Retrofit Condition.** What is the condition of the retrofit structures? Drop down menu.

**Outlet Sill.** Is there a sill inside the culvert segment at the outlet?

**Inlet Type.** What does the segment inlet look like?

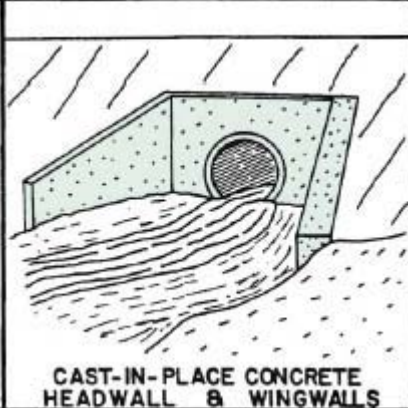
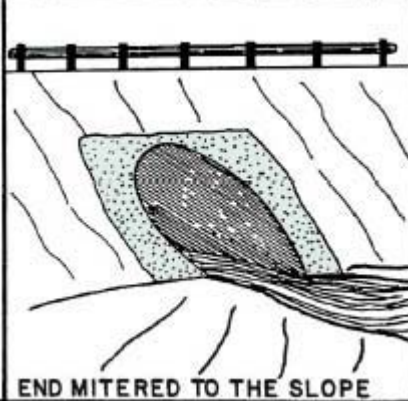
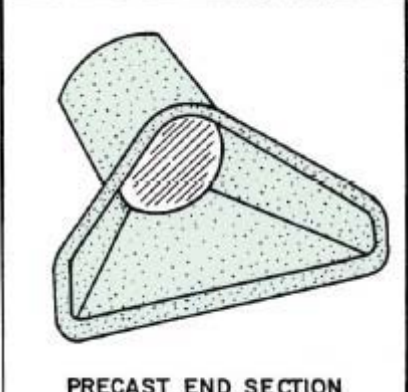
<p><b>Projecting.</b> Culvert barrel projects upstream out of the road fill.</p>	 <p>PROJECTING BARREL</p>
<p><b>Headwall.</b> Culvert barrel is flush with road prism, that is often set within a vertical concrete headwall.</p> <p><b>Wingwall.</b> Concrete walls that extend out from the culvert inlet in an upstream direction and usually increase a crossings flow capacity.</p>	 <p>CAST-IN-PLACE CONCRETE HEADWALL &amp; WINGWALLS</p>
<p><b>Mitered.</b> Culvert inlet is cut on an angle similar to angle of the road prism, increasing the size of the opening and the flow capacity.</p>	 <p>END MITERED TO THE SLOPE</p>
<p><b>Flared End Section.</b> Flared inlet secured to culvert to increase capacity.</p>	 <p>PRECAST END SECTION</p>
<p><b>Segment Connection.</b> The upstream end of the segment is a connection to another culvert segment (multiple segment culvert).</p>	

**Act Chnl W => Culv.** Is the active channel width (measured away from the influence of the culvert) equal or greater than the total culvert width?

**Inlet Chnl Align.** Alignment of the channel to the inlet. While standing at the inlet and looking upstream, estimate the stream channel approach angle with respect to the inlet. Check: <30, 30 - 45, >45. Channel approach angles greater than 30° may increase the likelihood of a stream crossing plugging with debris during storm flows, which impedes fish passage and can result in catastrophic failure of the stream crossing and road prism. In some instances, poor channel alignment creates adverse hydraulic conditions that inhibit or prevent fish passage.

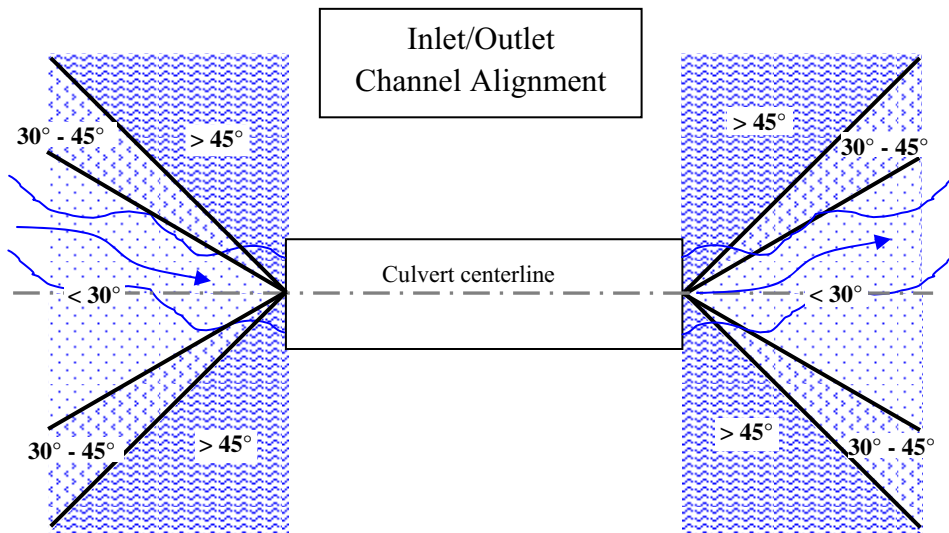

**Inlet Description.** Describe any inlet features influencing passage (apron type, shape, material). If none, enter “n/a”.

**Inlet Apron.** Is there an inlet apron? If no, leave next 3 fields blank.

**InletApnUSWdth (ft.).** Width of the inlet apron at the furthest upstream point.

**InletApnDSWdth (ft.).** Width of the inlet apron at the culvert inlet.

**InletApnLgth (ft.).** Length of inlet apron.

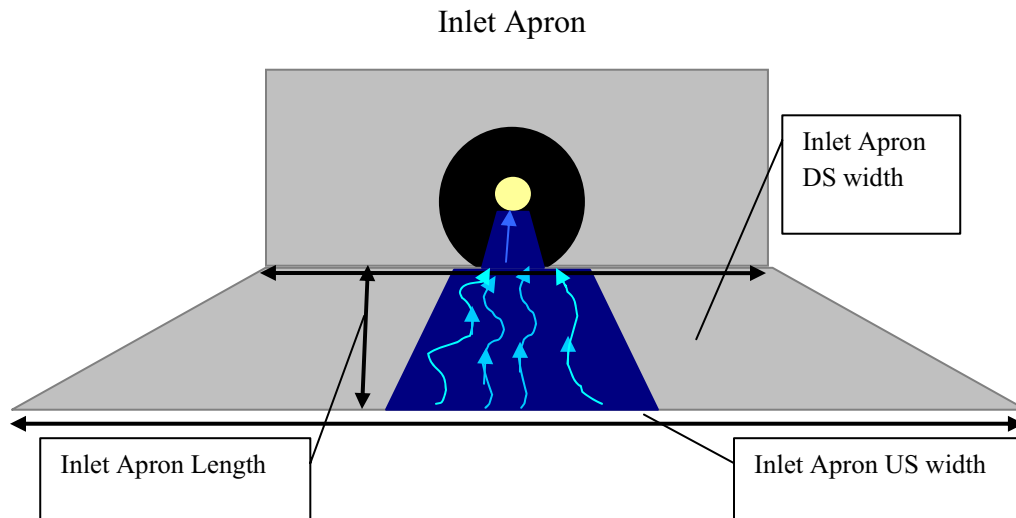

**Outlet Type.** What is the type of segment outlet? Drop down menu; same choices as for “Inlet Type”

**Outlet Chnl Align.** Alignment of the outlet to the channel. Similar to inlet alignment.

**Outlet Description.** Describe any outlet features influencing passage (apron type, shape, material). If none, enter “n/a”.

**Outlet Configuration.** How does the outlet relate to the downstream channel? Drop down menu of choices.

**At stream grade.** A swim through culvert that has no drop at the outlet.

**Freefall into pool.** Culvert outlet is perched directly over the outlet pool. Requires migrating fish to leap into culvert from outlet pool.

**Cascade over riprap.** Culvert outlet is perched above the downstream channel and exiting water flows (or sheets) over riprap, concrete, and/or bedrock.

**Freefall onto apron.** Culvert outlet is perched above an apron.

**Outlet El Drop (ft.).** Distance from the culvert bottom to the water surface below. If stream is dry, give the physical drop from the culvert to the apron or stream bed as a conservative measure. Hydraulic drop will be determined during second pass assessments.

**Max Pool Depth (ft.).** Measure the deepest part of the outlet pool that is within 5 feet of the culvert outlet or downstream apron. If the stream is dry, enter “0”.

**Riprap Runout Dist.** Length of riprap from culvert outlet to the first downstream pool. Take a picture. If no riprap, enter “0”.

**Weir Present.** Is there a weir at or near the culvert outlet?

**Fish Ladder.** Is there a fish ladder to the culvert outlet?

**Outlet Apron.** Is there a segment outlet apron? If no, leave next 3 fields blank.

**OutletApUSWdth (ft.).** Width of the outlet apron at the culvert outlet.

**OutletApDSWdh (ft.).** Width of the outlet apron at the furthest downstream point.

**OutletApnLgth (ft.).** Length of outlet apron.

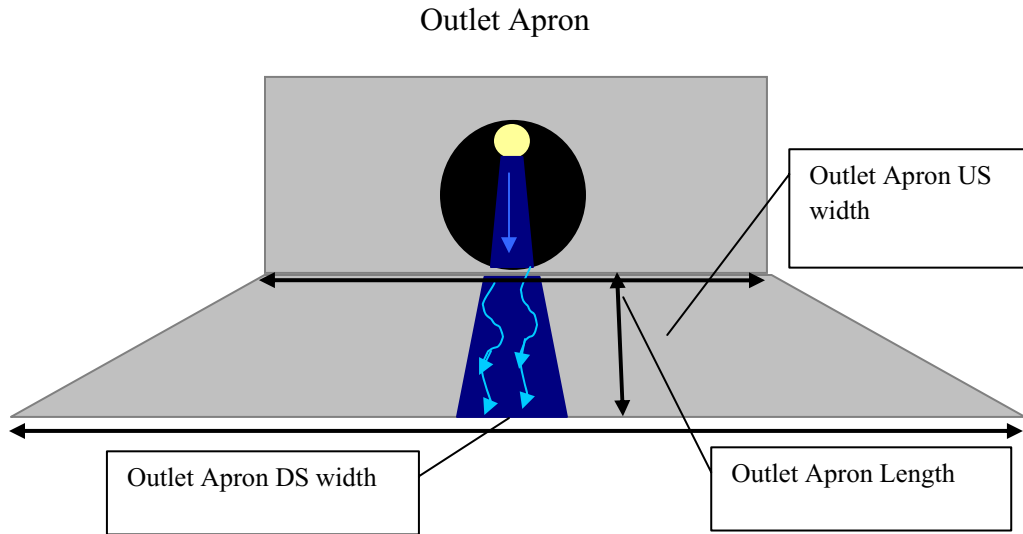

*[This page has been intentionally left blank]*

## **APPENDIX C**



*[This page has been intentionally left blank]*

## SJRRP FISH PASSAGE INVENTORY DATA SHEET

County:	River Mile:	Date:	Page of Pages
---------	-------------	-------	---------------

### FIRST PASS SURVEY INFORMATION

#### SURVEYOR INFORMATION

Date:	Time:	Agency performing survey:
Data recorder:		Survey team:

#### SURVEY CONTROL INFORMATION

**GPS Information:**  
 Location of GPS point taken:  At structure       Distance from structure \_\_\_\_\_ (ft)

Known Latitude:	Known Longitude:	GPS Unit Brand:
-----------------	------------------	-----------------

#### SITE INFORMATION

Stream Name: \_\_\_\_\_

County:	Road:	River/Bypass Mile:
---------	-------	--------------------

Crossing Type:  bridge     natural barrier     control structure     dam     weir/low flow crossing     culvert     other  
 Comments: \_\_\_\_\_

#### ACCESS INFORMATION

Temporary Entry Permit obtained?  yes     not needed      Accessibility Limitations:  none  
 Limitations Comments: \_\_\_\_\_

Major vegetation removal required for work at site?     Yes     No     Maybe

Confined Space Issue:  none     culvert <60"     cannot see through culvert     cannot feel breeze  
 Note: If any of the above boxes are checked, other than none, DO NOT ENTER STRUCTURE.

#### SITE INFORMATION (cont.)

**Flow Condition:** Is the stream  wet     dry     discontinuous

**Fish Presence** observed during first pass survey?  upstream     downstream     in structure     not accessible     no

Observation Summary: \_\_\_\_\_  
 \_\_\_\_\_  
 \_\_\_\_\_

**Channel Details:**  
 Channel Substrate: \_\_\_% silt/clay/sand(<0.08")    \_\_\_% gravel(0.08-2.5")    \_\_\_% cobble(2.5-10")    \_\_\_% boulder(>10")    \_\_\_% bedrock  
 Channel Vegetation:  Clean     Light weeds     Heavy weeds     Light brush     Heavy brush

Downstream Channel Characteristics: \_\_\_\_\_

<p><b>Observed Downstream Barrier:</b></p> <p><input type="checkbox"/> dam    <input type="checkbox"/> debris jam    <input type="checkbox"/> culvert    <input type="checkbox"/> falls    <input type="checkbox"/> steep gradient  <input type="checkbox"/> lack of habitat    <input type="checkbox"/> unknown    <input type="checkbox"/> none    <input type="checkbox"/> other</p> <p>Describe other : _____                  _____</p>	<p><b>Observed Upstream Barrier:</b></p> <p><input type="checkbox"/> dam    <input type="checkbox"/> debris jam    <input type="checkbox"/> culvert    <input type="checkbox"/> falls    <input type="checkbox"/> steep gradient  <input type="checkbox"/> lack of habitat    <input type="checkbox"/> unknown    <input type="checkbox"/> none    <input type="checkbox"/> other</p> <p>Describe other : _____                  _____</p>
--	--

## SJRRP FISH PASSAGE INVENTORY DATA SHEET

County:	River Mile:	Date:	Page of Pages
---------	-------------	-------	---------------

### SITE INFORMATION (cont.)

**Trash Rack**     Yes     No

Distance to trash rack : \_\_\_\_\_ ft

Rack condition at survey:  clean     full     partially full     bypassed by stream channel

Photograph(s) taken or already existing of trash rack

### BRIDGE INFORMATION

Height/Rise: \_\_\_\_\_ (ft)    Width/Span: \_\_\_\_\_ (ft)    Length: \_\_\_\_\_ (ft)    Drop: \_\_\_\_\_ (ft)

Active Channel Width: \_\_\_\_\_ (ft)    # of Bridge Piers: \_\_\_\_\_    Distance between piers: \_\_\_\_\_ (ft)

Is there a hydraulic jump present?  yes     no    Apron and/or Riprap scour protection?  yes     no

Is it submerged?  yes     no

If site is a bridge, stop here. Take photographs and fill in the site sketch and description.

### NATURAL BARRIER INFORMATION

**DESCRIPTION:**     Ford     Chute     Dam/Debris Jam     Waterfall     Other

\_\_\_\_\_

Height/Rise: \_\_\_\_\_ (ft)    Width/Span: \_\_\_\_\_ (ft)    Length: \_\_\_\_\_ (ft)    Drop: \_\_\_\_\_ (ft)

Can it be bypassed?     Yes     No

**Downstream:**

Max. Pool Depth Downstream: \_\_\_\_\_ (ft)    Max. Pool Distance: \_\_\_\_\_ (ft)

If no other barriers present, stop here. Take photographs and fill in the site sketch and description.

### CONTROL STRUCTURE INFORMATION

**GATE DESCRIPTION:**     Radial     Slide     Flap     Tilting     Other

\_\_\_\_\_

**OPENINGS:**    Total # of Openings: \_\_\_\_\_

Height: \_\_\_\_\_ (ft)    Width: \_\_\_\_\_ (ft)    Max. Height of Openings from channel bottom: \_\_\_\_\_ (ft)

Structure Height: \_\_\_\_\_ (ft)    Structure Length: \_\_\_\_\_ (ft)

Is there an outlet drop?     Yes     No     CND    Drop: \_\_\_\_\_ (ft)

Can it be bypassed?     Yes     No

Fish Ladder:     Yes     No

**Downstream:**

Max. Pool Depth Downstream: \_\_\_\_\_ (ft)    Max. Pool Distance: \_\_\_\_\_ (ft)

If no other barriers present, stop here. Take photographs and fill in the site sketch and description.

## SJRRP FISH PASSAGE INVENTORY DATA SHEET

County: _____	River Mile: _____	Date: _____	Page of Pages
---------------	-------------------	-------------	---------------

### DAM INFORMATION

**DAM NAME:** \_\_\_\_\_

Height/Rise: \_\_\_\_\_ (ft)      Width/Span: \_\_\_\_\_ (ft)

Bankfull Channel Width: \_\_\_\_\_ (ft)

Drop from dam base to channel bed/apron: \_\_\_\_\_ (ft)

Apron and/or Riprap scour protection?  yes  no      Is it submerged?  yes  no

Fish Ladder:  Yes  No

Dam control description: (Describe uniqueness of control features)

---



---

**Downstream:**  
 Max. Pool Depth downstream w/in 5 ft of weir: \_\_\_\_\_ (ft)  
 Max. Pool Distance from weir: \_\_\_\_\_ (ft)

**Upstream:**  
 Max. Pool Distance from weir: \_\_\_\_\_ (ft) at 1' depth.

If no other barriers present, stop here. Take photographs and fill in the site sketch and description.

### WEIR INFORMATION

**WEIR** \_\_\_\_\_ of \_\_\_\_\_

**OPENING** \_\_\_\_\_ of \_\_\_\_\_

**WEIR TYPE:**  Sharp-crested     Broad-crested

**WEIR SHAPE:**  Rectangular     Trapezoidal     Triangular     Other

Height/Rise: \_\_\_\_\_ (ft)      Width/Span: \_\_\_\_\_ (ft)      Length: \_\_\_\_\_ (ft)      Drop: \_\_\_\_\_ (ft)

Is it submerged?  yes  no

Weir shape description: (Describe uniqueness of shape)

---

**OPENINGS:** Total # of Openings: \_\_\_\_\_  
 Opening Dimensions: \_\_\_\_\_ (ft)

**Upstream:**  
 Max. Pool Distance from weir: \_\_\_\_\_ (ft) at 1' depth.

**Downstream:**  
 Max. Pool Depth downstream w/in 5 ft of weir: \_\_\_\_\_ (ft)  
 Max. Pool Distance from weir: \_\_\_\_\_ (ft)

Fish Ladder:  Yes  No

Concrete Apron or Rip Rap:  Yes  No

If no other barriers present, stop here. Take photographs and fill in the site sketch and description.

### LOW FLOW CROSSING INFORMATION

**Structure Name:** \_\_\_\_\_

Height/Rise: \_\_\_\_\_ (ft)      Width/Span: \_\_\_\_\_ (ft)      Length: \_\_\_\_\_ (ft)

Bankfull Channel Width: \_\_\_\_\_ (ft)

Drop from base to channel bed/apron: \_\_\_\_\_ (ft)

Apron and/or Riprap scour protection?  yes  no      Is it submerged?  yes  no

Fish Ladder:  Yes  No

Crossing description: (Describe uniqueness of the crossing)

---



---

Fill in culvert section if culverts are present. Otherwise, if no other barriers present, stop here. Take photographs and fill in the site sketch and description.

## SJRRP FISH PASSAGE INVENTORY DATA SHEET

County: _____	River Mile: _____	Date: _____	Page of Pages
---------------	-------------------	-------------	---------------

### CULVERT SEGMENT INFORMATION

<b>CULVERT</b> _____ <b>of</b> _____	<b>SEGMENT #</b> _____ <b>of</b> _____
--------------------------------------	--

**CULVERT SEGMENT SHAPE:**  
 Arch  
 Arch-Top Box  
 Box  
 Circular pipe  
 Pipe-arch  
 Elliptical pipe

Diameter: \_\_\_\_\_ (ft)  
 Height/Rise: \_\_\_\_\_ (ft)  
 Width/Span: \_\_\_\_\_ (ft)  
 Length: \_\_\_\_\_ (ft)

Culvert segment shape description: (Describe uniqueness of shape)

\_\_\_\_\_

Rustline height: \_\_\_\_\_ (ft)

Upstream culvert segment end type:  
 inlet  
 culvert segment connection  
 discontinuous (gap in segment)

Downstream culvert segment end type:  
 outlet  
 culvert segment connection  
 discontinuous (gap in segment)

Culvert connection description: (comments on this segment and its connections to upstream/downstream segments)

\_\_\_\_\_

\_\_\_\_\_

**CULVERT SEGMENT**

**Material:**

- Annular and Helical (125 mm x 25 mm) (circle one)
- Annular and Helical (152 mm x 51 mm) (circle one)
- Annular and Helical (229 mm x 64 mm) (circle one)
- Annular and Helical (68 mm x 13 mm) (circle one)
- Annular and Helical (76 mm x 25 mm) (circle one)
- Cast Iron Pipe
- Clay Sewer Pipe
- Composite Steel Spiral Rib Pipe
- Concrete
- Concrete Pipe (Cast-in-place)
- Concrete Pipe (Pre-cast)
- Plastic Pipe (Corrugated Interior)
- Plastic Pipe (Smooth Interior)
- Spiral Rib Metal Pipe (19 mm (W) x 19 mm (D) @ 191 mm o/c)
- Spiral Rib Metal Pipe (19 mm (W) x 25 mm (D) @ 213 mm o/c)
- Spiral Rib Metal Pipe (19 mm (W) x 25 mm (D) @ 292 mm o/c)
- Steel Pipe, Ungalvanized
- Structural Plate
- Other: \_\_\_\_\_

**CULVERT SEGMENT Bottom/Lining**

**Material:**

- Same as segment material
- Annular and Helical (125 mm x 25 mm) (circle one)
- Annular and Helical (152 mm x 51 mm) (circle one)
- Annular and Helical (229 mm x 64 mm) (circle one)
- Annular and Helical (68 mm x 13 mm) (circle one)
- Annular and Helical (76 mm x 25 mm) (circle one)
- Cast Iron Pipe
- Clay Sewer Pipe
- Composite Steel Spiral Rib Pipe
- Concrete
- Concrete Pipe (Cast-in-place)
- Concrete Pipe (Pre-cast)
- Plastic Pipe (Corrugated Interior)
- Plastic Pipe (Smooth Interior)
- Spiral Rib Metal Pipe (19 mm (W) x 19 mm (D) @ 191 mm o/c)
- Spiral Rib Metal Pipe (19 mm (W) x 25 mm (D) @ 213 mm o/c)
- Spiral Rib Metal Pipe (19 mm (W) x 25 mm (D) @ 292 mm o/c)
- Steel Pipe, Ungalvanized
- Structural Plate
- Bitumous Coating
- Plastic
- Grouted Rock
- Natural Substrate
- Other: \_\_\_\_\_

**SJRRP FISH PASSAGE INVENTORY DATA SHEET**

County: _____	River Mile: _____	Date: _____	Page of Pages
---------------	-------------------	-------------	---------------

**CULVERT INFORMATION (cont.)**

Culvert _____ of _____	Segment _____ of _____
------------------------	------------------------

**Culvert Bottom**

If bottom material (not open arch culvert) is natural substrate, is it embedded?     Yes     No  
 If YES, is it embedded:     partially     fully

Length of embeddness: \_\_\_\_\_ (ft)    Beginning depth: \_\_\_\_\_ (ft)    Ending depth: \_\_\_\_\_ (ft)

Dominant Substrate:  Silt/Clay     Sand (<0.08")     Gravel (0.08-2.5")     Cobble (2.5-10")     Boulder (>10")     Bedrock

**CULVERT SEGMENT RETROFIT**

Retrofit type:     none     corner baffles     gravel retention weirs     notched weirs     offset baffles     ramp baffle  
 Condition:     Good     Fair     Poor     Non-Functional  
 Outlet Sill (inside culvert at outlet):     yes     no

<b>INLET</b>	<b>OUTLET</b>
--------------	---------------

**INLET TYPE:**     projecting     headwall     wingwall  
 mitered     flared end section     segment connection

Average active channel width = or > than total culvert width  
 (measure of channel away from influence of culvert)  
 yes     no

Alignment:     < 30°     30-45°     >45°  
 (inlet to channel)

Inlet Description: (Describe apron type, shape, material and other features influencing fish passage)

\_\_\_\_\_

\_\_\_\_\_

\_\_\_\_\_

**INLET APRON:**     yes     no

Upstream width: \_\_\_\_\_ (ft)  
 (width of apron at furthest upstream point)

Downstream width: \_\_\_\_\_ (ft)  
 (width of apron at culvert inlet)

Length of inlet apron: \_\_\_\_\_ (ft)

**OUTLET TYPE:**     projecting     headwall     wingwall  
 mitered     flared end section     segment connection

Alignment:     < 30°     30-45°     >45°  
 (outlet to channel)

Outlet Description: (Describe apron type, shape, material and other features influencing fish passage)

\_\_\_\_\_

\_\_\_\_\_

**OUTLET CONFIGURATION:**

at stream grade     freefall into pool     cascade over riprap  
 freefall to apron

Outlet Elevation Drop: \_\_\_\_\_ (ft)  
 (measured from culvert invert to water surface)

Max. Pool Depth w/in 5 ft of outlet or apron: \_\_\_\_\_ (ft)  
 Riprap run-out distance to first pool (Photo): \_\_\_\_\_ (ft)

Weir present:     Yes     No  
 Fish Ladder:     Yes     No

**OUTLET APRON:**     yes     no

Upstream width: \_\_\_\_\_ (ft)  
 (width of apron at outlet)

Downstream width: \_\_\_\_\_ (ft)  
 (width of apron at the furthest downstream point)

Length of outlet apron: \_\_\_\_\_ (ft)

**SJRRP FISH PASSAGE INVENTORY DATA SHEET**

County:	River Mile:	Date:	Page of Pages
---------	-------------	-------	---------------

**PHOTOGRAPHS**

**PHOTOS TAKEN:**

Upstream looking upstream. Comments: \_\_\_\_\_

Upstream looking downstream. Comments: \_\_\_\_\_

Downstream looking upstream. Comments: \_\_\_\_\_

Downstream looking downstream: Comments: \_\_\_\_\_

**ADDITIONAL PHOTOS:**

Orientation of photo with comments:

A.

B.

C.

D.

E.

F.

G.

# SJRRP FISH PASSAGE INVENTORY DATA SHEET

County:	River Mile:	Date:	Page	of	Pages
---------	-------------	-------	------	----	-------

**Site Sketch (Plan/Profile/Details):**

**Site Description:** (Unique features of the site)

---

---

---

---

---



*[This page has been intentionally left blank]*

## **APPENDIX D**

*[This page has been intentionally left blank]*

Title: North Fork Road, Road 206 Bridge

Identification Number: 2 and 3

Ranking: Green

Description: The Road 206 Bridge (Photo 2\_A) is a two lane bridge about 0.7 miles downstream Friant Dam in the town of Friant. The bridge crosses perpendicular to the San Joaquin River near river mile near 266.8. The bridge has a span of 306 feet with a width of about 36 feet and height of 26.5 feet. The active channel width at the bridge was measured at 135 feet. There are a total of ten bridge piers, five sets of two each. The distance between the piers was measured at 45 feet. The maximum water surface elevation just upstream the bridge was measured as 7 feet. The channel substrate was mostly cobble with some boulders.

Upstream the bridge, the channel is split between an island. The channel upstream and downstream had large woody trees and brush on the banks with tall annual grass in the floodplain.

About 200 feet downstream the bridge is an older bridge that was demolished and large sections of the bridge were left in the channel. The sections in the channel average between 50 – 100 feet apart. Two sections just downstream the bridge are located in the center of the active channel and have created a cascading drop (Photo 2\_B). This section does not appear to be a fish passage issue since it can be bypassed.

Evaluation: The bridge has no apron or riprap scour protection, the bridge span is greater than the active channel width and there is no visible water surface difference between one side of the structure and the other, therefore based on the criteria it is not a barrier to fish migration.

Photos:

Photo 2\_A. Bridge looking upstream from downstream



Photo 2\_B. Bridge debris from Road 206 Bridge looking downstream



Title: Lost Lake Rock Weir #1

Identification Number: 4

Ranking: Gray

Description: The rock weir is located in Lost Lake Park on the San Joaquin River near river mile 266. This site is publicly accessible through the Lost Lake Park campgrounds, a Fresno County operated facility, and is not accessible for day use visitors. The weir cannot be bypassed and extends the length of the active channel. The weir appears to be man made with large boulders placed into the channel. Large vegetation has taken root at the center of the weir (Photo 4\_A). The weir width was measured at 50 feet with a length of 77 feet from the left bank to the vegetation (Photo 4\_B). Total weir length is estimated at 115 feet. The water surface elevation upstream the weir was measured as 4.1 feet. The pool depth downstream the weir within five feet was measured as a water surface of at 2.6 feet. The weir was submerged during the survey with only the tops of the boulders visible. There were rainbow trout seen upstream the weir.

The channel substrate is mostly bedrock with some boulders, cobble, and gravel. The channel is clean with the floodplain on the left bank maintained as a park setting with short grass, tall woody trees, campground areas, and parking. The right bank has mostly tall annual grasses, dense brush with tall woody trees.

Evaluation: This site ranked gray due to the structures overall height of greater than two feet and that it cannot be bypassed. A model should be developed to determine the flows, if any, that it is not passable.

Photos:

Photo 4\_A. Rock weir looking upstream from downstream



Photo 4\_B. Rock weir from upstream looking downstream



Title: Lost Lake Rock Weir #2

Identification Number: 5

Rank: Gray

Description: There is a man made rock weir (Photo 5\_A) at Lost Lake Park near river mile 265. This site is publicly accessible through Lost Lake Park, a Fresno County operated facility. The weir cannot be bypassed and extends the length of the active channel. Some of the rocks appear to be set in concrete and some large boulders are placed in the channel to create a backwater pool for the park. About 84 feet of the weir is clean and visible, but the remaining section has heavy vegetation that consists of large woody trees and heavy brush (Photos 5\_B and 5\_C). Total length is estimated at 425 feet. One of the parks attractions is fishing for rainbow trout that is planted by an upstream hatchery. The pool likely serves as a pond for this sport. There were rainbow trout and stickleback (Three Spine) seen upstream the weir.

About 225 feet downstream there is a rock weir that appears to be natural falls with mostly bedrock (Photo 5\_E). The falls can be bypassed, but any fish swimming upstream would encounter the man made rock weir.

The channel substrate is mostly bedrock with some boulders, cobble, and gravel. The channel is clean with the floodplain on the left bank maintained as a park setting with short grass, tall woody trees, picnic areas, and parking. The right bank has mostly tall annual grasses with tall woody trees.

Evaluation: This site ranked gray due to the structures overall height greater than two feet and that it cannot be bypassed. A model should be developed to determine the flows, if any, that it is not passable.

Photos:

Photo 5 A. Rock weir looking downstream



Photo 5 B. Rock weir from upstream looking downstream



Photo 5\_C. Rock weir vegetation from upstream looking downstream



Photo 5\_D. Rock weir from downstream looking upstream



Photo 5\_E. Falls downstream of weir from downstream looking upstream



Photo 5\_F. Channel downstream falls and weir



Photo 5\_G. Channel upstream weir



Title: Riffles

Identification Number: 7

Rank: Green

Description: The riffle is located on the San Joaquin River near river mile 260.7. This site has an active sediment transport study and limited disturbance to the channel substrate is requested. Measurements were not taken as a result, but were provided by the project lead, Matt Meyers. At low flow conditions the maximum velocity is 3 feet-per-second (ft/s) and the bankfull maximum velocity is about 10 ft/s. The bankfull width is from 175 feet to 120 feet. The riffle length is about 400 feet. The bankfull depth is about 4 feet at the riffle crest (most shallow point). The maximum bed slope is estimate at 0.01 with an average bedslope of 0.006 for the riffle.

Evaluation: The ranking was determined to be green since the riffle has a slope less than three percent and velocities do not restrict passage.

Photos:

Photo 7\_A. Riffle looking upstream





Title: Vulcan Crossing

Identification Number: 9

Rank: Green

Description: The crossing is located near river mile 258.5 on private property in the Vulcan mining operations. The Vulcan crossing is not publicly accessible, but is used for mining operations during flows that are passable (Photo 9\_A). There were three separate equipment crossing in a half-hour during the survey. The crossing is maintained and consists mostly of cobble with some gravel and sand. The crossing is at stream grade upstream and gradually slopes downstream creating a riffle, so there is no dramatic drop. Downstream the channel narrows and the flow velocity increases (Photo 9\_B). The crossing height from 77 feet downstream was measured as 2.6 feet. The crossing height used for the ranking was zero, or at stream grade since there is a gradual slope downstream. The water surface elevation was 1.8 feet at the center of the crossing. The crossing width was measured as 41 feet at the widest with a length of 137 feet with the bankfull channel width at the crossing measured as 110 feet.

The upstream channel is split flow with islands that have heavy vegetation. The channel downstream is clean and narrows. There are willows and heavy vegetation on the banks upstream and downstream.

Evaluation: The ranking was determined to be green since the crossing is mostly at channel grade and when flow is reduced will continue to be submerged and will flow over the crossing unimpeded.

Photos:

Photo 9\_A. Crossing looking north



Photo 9\_B. Channel looking downstream from the crossing



Title: Frontage Road Bridge

Identification Number: 10

Rank: Green

Description: The two lane bridge is located just upstream the north bound Highway 41 bridge and was the former Highway 41 bridge near river mile 255.2. The total number of bridge piers is 11 and the pier width measured as 24 feet with a distance of 56 feet between piers. Just upstream the bridge, there are two mobile home parks on either bank of the river.

The channel substrate is mostly cobble and gravel. There were small minnows observed just upstream the bridge.

Evaluation: The bridge has no apron or riprap scour protection, the bridge span is greater than the active channel width and there is no visible water surface difference between one side of the structure and the other, therefore based on the criteria it is not a barrier to fish migration.

Photos:

Photo 10\_A. Bridge looking upstream



Photo 10\_B. Channel from upstream left bank looking downstream



Title: Highway 41 Bridges

Identification Number: 11

Rank: Green

Description: There are two Highway 41 bridges; two lane bridges each for the north and south bound lanes near river mile 255.2 (Photo 11\_A). The number of bridge piers could not be determined but one of the piers on the north bound bridge was measured as 44.5 feet wide. The bridges are too large to take measurements from under and it is not safe to take measurements from the bridge deck. Just upstream the north bound bridge there is a two lane frontage road bridge that was the former Highway 41 bridge.

The channel substrate is mostly cobble and gravel. The channel is clean with brush and large woody trees on the banks with tall annual grasses in the floodplain. The active channel width at the center of the bridges was measured as 97.2 feet.

Evaluation: The bridge has no apron or riprap scour protection, the bridge span is greater than the active channel width and there is no visible water surface difference between one side of the structure and the other, therefore based on the criteria it is not a barrier to fish migration.

Photos:

Photo 11\_A. Bridges looking downstream from the frontage bridge



Photo 11\_B. Channel between bridges looking downstream



Title: Retired Crossing

Identification Number: 12

Rank: Green

Description: The riffle is located on the San Joaquin River near river mile 253.4 (Photo 12\_A). The crossing was part of a mining operation that is no longer active on the river and currently resembles a small riffle. The floodplain on the right bank is located at Sycamore Island. This site is publicly accessible when the Sycamore Island Park is open. Evidence of the crossing is still visible on the left bank but has been overgrown with vegetation on the right bank (Photo 12\_B). The channel substrate in the area was mostly cobble with some gravel. The channel upstream and downstream is clean with dense brush on the banks and tall annual grasses in the floodplain. Fish were observed just upstream that looked like rainbow trout about 12 inches in length.

Evaluation: The ranking was determined to be green since the riffle has a very flat slope and velocities would not restrict passage. The riffle is at stream grade and will be submerged as long as there are flows.

Photos:

Photo 12\_A. Washed out crossing



Photo 12\_B. Crossing from left bank



Title: Culverts between gravel-mining ponds - Removed

Identification Number: 13

Rank: Green

Description: The crossing was located on the San Joaquin River near river mile 253 (Photo 13\_A). The crossing was part of a mining operation that is no longer active on the river. The floodplain on the right bank is located at Sycamore Island (Photo 13\_B). This site is publicly accessible when the Sycamore Island Park is open and the left bank has public access via Nees Avenue. Evidence of the crossing is still visible from remaining islands in the center of the channel and access roads on the banks (Photo 13\_C). The channel is split as a result of the crossing island. The channel substrate in the area was mostly gravel and sand with some cobble. The channel upstream and downstream is clean with dense brush on the banks and tall annual grasses in the floodplain. A dead fish was observed on the channel bottom just upstream that looked like about 12 inches in length.

Evaluation: The ranking was determined to be green since there was no crossing or channel formations that would restrict passage.

Photos:

Photo 13\_A. Removed crossing



Photo 13\_B. Crossing at right bank



Photo 13\_C. Crossing looking east at Nees Avenue



Photo 13\_D. Channel looking upstream



Title: Railroad Crossing

Identification Number: 14

Rank: Green

Description: The crossing is located on the San Joaquin River at river mile 245.2. The railroad bridge is quite large and spans the river at an elevation from bluff to bluff (Photo 14\_A). Access was limited since it was viewed from the bluff. The crossing center has a large metal truss that spans three piers then in the floodplain has four piers, for a total of seven piers. The bridge dimensions were not measured, because the crossing is obviously not a fish barrier and access was restricted.

The channel is clean with brush and large woody trees on the banks with tall annual grasses in the floodplain. There were remnants of an older crossing remaining in the channel and seen as jagged broken wooden piers (Photo 14\_B). These piers would not restrict fish migration since they can be bypassed.

Evaluation: The bridge has no apron or riprap scour protection, the bridge span is greater than the active channel width and there is no visible water surface difference between one side of the structure and the other, therefore based on the criteria it is not a barrier to fish migration.

Photos:

Photo 14\_A. Bridge looking downstream



Photo 14\_B. Old wooden piers in channel



Title: Railroad Crossing

Identification Number: 15

Rank: Green

Description: The crossing is located on the San Joaquin River near river mile 243.2. The railroad bridge is quite large and spans the river at an elevation from bluff to bluff (Photo 15\_A). The bridge piers were located outside the active channel. The bridge dimensions were not measured, because the crossing is obviously not a fish barrier and access was restricted. Just downstream the crossing is two bridges for Highway 99.

The channel is clean with brush and large woody trees on the banks with tall annual grasses in the floodplain. The active channel width just downstream of the crossing was measured as 69 feet.

Evaluation: The bridge has no apron or riprap scour protection, the bridge span is greater than the active channel width and there is no visible water surface difference between one side of the structure and the other, therefore based on the criteria it is not a barrier to fish migration.

Photos:

Photo 15\_A. Crossing looking downstream



Photo 15\_B. Pier near channel on right bank





Title: Highway 99 Bridges

Identification Number: 16

Rank: Green

Description: There are two Highway 99 bridges; two lane bridges each for the north and south bound lanes near river mile 243.2 (Photo 16\_A). There are a total of five bridge piers for each crossing and the piers were located outside the active channel. The bridges are too large to take measurements from under and it is not safe to take measurements from the bridge deck. Just upstream the north bound bridge there is a railroad crossing and downstream the south bound bridge is remnants of an older crossing (Photo 16\_D).

The channel is clean with brush and large woody trees on the banks with tall annual grasses in the floodplain (Photo 16\_B). The active channel width upstream of the bridges was measured as 69 feet.

Evaluation: The bridge has no apron or riprap scour protection, the bridge span is greater than the active channel width and there is no visible water surface difference between one side of the structure and the other, therefore based on the criteria it is not a barrier to fish migration.

Photos:

Photo 16\_A. Bridge looking upstream



Photo 16\_B. Channel downstream bridges looking upstream



Photo 16\_C. Channel upstream bridges looking downstream



Photo 16\_D. Wooden piers from old crossing



Title: Donny Bridge

Identification Number: 17

Rank: Gray

Description: Donny Bridge has private access and does not look like it is currently being used, but appears to be maintained for water data collection (Photo 17\_A). The bridge was likely used for private equipment crossing. There is a concrete bridge deck with a metal truss and 12 inch diameter steel pipes for the piers. The bridge height was measured as 13.4 feet from the channel thalweg with a width of 16 feet and a span of about 52 feet. The total number of bridge piers is four and measured 17.1 feet apart.

The water surface elevation upstream the bridge was measured as 6.5 feet. The channel substrate is mostly sand with gravel and some cobble and boulders. The channel is clean with brush and large woody trees on the banks with tall annual grasses in the floodplain. The active channel width at the bridge measured as 37.5 feet. The channel upstream and downstream is much wider and was estimated at about 150 feet (Photo 17\_B).

Evaluation: The bridge has no apron or riprap scour protection and there is no visible water surface difference between one side of the structure and the other, but the active channel upstream is greater than the bridge opening so it may be a barrier to fish migration. A hydraulic model should be completed to determine at what flows, if any, the bridge is a barrier to fish passage.

Photos:

Photo 17\_A. Bridges looking downstream



Photo 17\_B. Channel upstream



Title: Skaggs Bridge, Highway 145

Identification Number: 18

Rank: Green

Description: The two lane bridge is located on the San Joaquin River near river mile 234.2 (Photo 18\_A). There are a total of four bridge piers. The bridge channel was too deep to wade to take measurements from under and it is not safe to take measurements from the bridge deck. Just downstream the bridge there is an island that is the remnants of an old ferry landing (Photo 18\_B). The location is publicly accessible from a Fresno County Park.

The channel is clean with brush and large woody trees on the banks with tall annual grasses in the floodplain. The channel substrate was gravel and sand. A large gravel bar was seen just under the bridge.

Evaluation: The bridge has no apron or riprap scour protection, the bridge span is greater than the active channel width and there is no visible water surface difference between one side of the structure and the other, therefore based on the criteria it is not a barrier to fish migration.

Photos:

Photo 18\_A. Bridge looking upstream



Photo 18\_B. Channel downstream bridge



Title: Chowchilla Bifurcation

Identification Number: 21

Ranking: Red

Description: The Chowchilla bifurcation structure is located at the apex of the Chowchilla Bypass and the San Joaquin River near river mile 168.5 (Photo 21\_A). The control structure has four radial gates that were closed during the survey. Each gate opening, bay, is 18 feet in height and 20 feet wide. The structure height is about 19.4 feet and measures 87.6 feet in total length from the top deck. The structure controls flood releases into the Chowchilla Bypass from the San Joaquin River. This structure is very similar to the bifurcation structure located on the San Joaquin River downstream.

The structure has a maintenance road that crosses over the gate openings with an opening in the center to access the radial gate arms (Photo 21\_B). The hoist motors are located at the top of each bay on the upstream deck. There is a solid concrete headwall that extends to the levee to the east and the levee connecting to the San Joaquin River Bifurcation structure to the west. The bays are 56.75 feet in length with a 15 foot concrete apron downstream. There are five 2 x 2 x 4 foot concrete block diffusers about 28.6 feet from the radial gate (Photo 21\_C).

The concrete apron has a short weir downstream that is about 2.5 feet tall and 1 foot wide (Photo 21\_D). There is a large pool downstream with rip rap to protect the concrete apron and weir from erosion. The rip rap protection extends about 30 feet downstream. The depth of the pool was not determined due to the depth exceeding what was able to be waded.

The channel upstream was clean with a sand bar in the middle of the channel (Photo 21\_E). The channel downstream had a large pool just downstream the structure and was clean with annual grasses and short brush in the channel downstream the pool (Photo 21\_F). The channel substrate majority was silt/clay/sand.

Evaluation: This structure has a drop greater than two feet at the outlet due to the concrete weir and rip rap. At different flows the drop would not be as significant and could become a gray site. The final determination is red due to the nature of the structures use for flood control and being gated, with gates only open during flood flows. While the gates are closed it is a barrier to fish.

Photos:

Photo 21\_A. The Chowchilla Bifurcation structure looking downstream



Photo 21\_B. The Chowchilla Bifurcation structure maintenance roads



Photo 21\_C. Diffusers and gate



Photo 21\_D. The Chowchilla Bifurcation structure looking upstream



Photo 21\_E. The channel looking upstream



Photo 21\_F. The channel looking downstream



Title: San Joaquin River Bifurcation

Identification Number: 22

Ranking: Red

Description: The bifurcation structure is located at the apex of the Chowchilla Bypass and the San Joaquin River near river mile 168.5 (Photo 22\_A). The control structure has four radial gates that were partially open during the survey. Each gate opening is 18 feet in height and 20.5 feet wide. The structure height is about 19.4 feet and measures 87.3 feet in total length from the top deck. The structure controls flood releases into the San Joaquin River. This structure is very similar to the bifurcation structure located on the Chowchilla structure upstream.

There is a trash rack at the inlet to the gate bays. The trash rack has 14 four inch galvanized pipe poles that are spaced 1.35 feet on center for each bay. It was estimated that there was a 20 degree angle on the trash rack. Large woody tree limbs and smaller debris has layered onto the trash racks that averaged about three feet in width. There was a fish carcass on the debris (Photo 22\_B).

The structure has a maintenance road that crosses over the gate openings with an opening in the center to access the radial gate arms. The hoist motors are located at the top of each bay on the upstream deck. There is a solid concrete headwall that extends to the levee to the south and the levee connecting to Chowchilla Bifurcation structure to the north. The bays are 57.6 feet in length with a 15 foot concrete apron downstream. There are five 2 x 2 x 4 foot concrete block diffusers about 28.6 feet from the radial gate (Photo 22\_C). The concrete apron has a short weir downstream that is about 2 feet tall and 1 foot wide (Photo 22\_D). The water surface elevation in the bays was 2.4 feet.

There is a large pool downstream with rip rap to protect the concrete apron and weir from erosion. The rip rap protection extends about 18 feet downstream. The drop to the pool from the weir is three feet. The depth of the pool was not determined due to the depth exceeding what was able to be waded. The channel upstream was clean with a sand bar in the middle of the channel (Photo 22\_E). The channel downstream was clean with annual grasses and short brush in the channel downstream the pool (Photo 22\_F). The channel substrate majority was silt/clay/sand.

Evaluation: This structure has a drop greater than two feet at the outlet due to the concrete weir and rip rap for low flows that would rank as a red site. At higher flows the drop would not be as significant and could become a gray site. The final determination is red due to the nature of the structure being gated with a trash rack. While the gates are closed it is a barrier to fish. In addition, debris trapped against the racks could prevent fish passage downstream or upstream.

Photos:

Photo 22\_A. San Joaquin River Bifurcation structure looking downstream



Photo 22\_B. Fish Carcass



Photo 22\_C. Concrete diffusers



Photo 22\_D. Concrete weir downstream



Photo 22\_E. Channel looking upstream



Photo 22\_F. Channel looking downstream





Title: San Mateo Avenue

Identification Number: 23

Ranking: Gray

Description: The San Mateo Avenue is a low flow crossing located on the San Joaquin River near river mile 211.8. During high flows the crossing is submerged. The crossing is an earthen road with some gravel armor and one culvert in the center of the road (Photo 23\_A). The crossing has a 407 feet span and is 44 feet wide with an average height measured from upstream at 4.6 feet. The active channel width was measured at 230 feet downstream. The upstream crossing slopes and culvert inlet are armored with old corrugate metal pipe that is filled with concrete and rebar (Photo 23\_B and C). The pipes appear to be acting as bank protection for the crossing upstream.

The culvert is a 7.2 foot circular pipe constructed of riveted and welded structural plate with a projecting inlet/outlet configuration (Photo 23\_D). The rustline height was measured at 4.5 feet from the bottom of the culvert inlet. The rustline was located at the current water surface elevation. The culvert is partially embedded and has natural substrate with a depth of 1.7 feet at the outlet. There was no outlet drop and the outlet was aligned to the centerline of the channel downstream. The inlet alignment was at a near 90 degree angle with the centerline of the channel (Photo 23\_E).

The river channel upstream is clean, except just upstream the culvert inlet there are trees in the channel. There is tall brush and large woody trees on the banks edge. Downstream the channel and the floodplain vegetation are similar to upstream. The channel substrate is mostly sand.

Evaluation: Based on the crossing height greater than two feet and culvert presence it is recommended to complete a hydraulic model to determine at what flows, if any, the crossing is a barrier to fish migration.

Photos:

Photo 23\_A. Crossing looking south



Photos 23\_B. Culvert inlet



Photo 23\_C. Culvert inlet looking upstream



Photo 23\_D. Culvert outlet looking downstream



Photo 23\_E. Channel, 90 angle, upstream inlet



Photo 23\_F. Culvert inlet



Photo 23\_G. The culvert outlet



Photo 23\_H. The channel looking upstream



Title: Avenue 7-1/2

Identification Number: 25

Ranking: Green

Description: The Avenue 7-1/2 or Q Street Bridge crosses perpendicular to the San Joaquin River near river mile 195.1 in the town of Firebaugh (Photo 25\_A). The bridge has two lanes and a pedestrian sidewalk it has a 608 feet span and 40 feet wide bridge deck. The concrete bridge has three piers that are about 170 feet apart. The center pier is located at the edge of the active channel. The active channel width was measured at 169 feet.

The river channel upstream is clean with tall annual grasses in the floodplain and large woody trees on the banks edge. Downstream the channel and the floodplain vegetation is similar to that of the upstream. The channel is too deep to wade and the water was very turbid. Channel substrate is silty sand.

Evaluation: The bridge has no apron or riprap scour protection, the bridge span is greater than the active channel width and there is no visible water surface difference between one side of the structure and the other, therefore based on the criteria it is not a barrier to fish migration.

Photos:

Photo 25\_A. Looking upstream at Bridge from left bank



Photos 25\_B. Looking upstream from Bridge



Title: Highway 152

Identification Number: 27

Ranking: Green

Description: The Highway 152 bridges cross perpendicular to the San Joaquin River near river mile 173.9. There are two separate concrete bridges with two lanes each, an eastbound (Photo 27\_A) and a westbound (Photo 27\_B). The eastbound bridge has four piers, two rows of two, which are about 108 feet apart. The eastbound bridge has a span of 395 feet and a width of 42 feet with a height of 19.8 feet. The active channel width was measured at 138 feet. The water surface elevation was 0.6 feet. A crawfish was seen in the channel under the eastbound bridge that measured about 6 inches in length.

The westbound bridge has a span of 395 feet and a width of 41 feet with a height of 21.7 feet. There are a total of 6 solid bridge piers that have a width of 32.2 feet with a distance of 68 feet between them. The water surface elevation was measured a 0.7 feet with an active channel width of 112 feet.

The river channel upstream is clean with a clean sandy floodplain and large woody trees on the banks edge. Downstream the channel and the floodplain vegetation are similar to that of the upstream, but had some trees in the channel. Channel substrate is silty sand.

Evaluation: The bridge has no apron or riprap scour protection, the bridge span is greater than the active channel width and there is no visible water surface difference between one side of the structure and the other, therefore based on the criteria it is not a barrier to fish migration.

Photos:

Photo 27\_A. Eastbound bridge looking upstream



Photos 27\_B. Westbound bridge looking downstream



Title: San Joaquin River Reach 4B Headgates

Identification Number: 28

Ranking: Red

Description: The San Joaquin River Reach 4B Headgates are located near river mile 168.4 (Photo 28\_A). The headgates are 4 screw valve for openings about 5.1 x 6 feet (Photo 28\_B). The gates are currently silted in and have not been operated in some time. The gates appear to be manually operated and are currently locked. The pool upstream was not accessible due to the silt that has deposited. There is a concrete wingwall on the banks upstream, so potentially could have a concrete sill. The crews were knee deep in the silt and there were concerns for the safety of the crews to continue to wade further into the silt. The culverts are about 49.7 feet in length with a height of 9.3 feet to the top of the headwall at the outlet and 4.2 feet at the inlets.

There was a weir about 35 feet downstream the gates at the end of the apron (Photo 28\_C). The pool depth was about 3.3 feet. The pool was choked with water hyacinth. There are 6 openings with 4.5 x 4.5 feet dimensions that were choked with vegetation. The openings have slots for either slide gates or stop logs that would be manually installed. Two of the openings, one on each end, had different dimensions; the opening height was reduced. The weir height was 6.7 feet and is 61 feet in length. The weir was partially submerged during the survey.

The channel downstream is very choked with vegetation and has a limited channel capacity. The channel just upstream has tall weeds (Photo 28\_D).

Evaluation: Due to the gates being closed and limited channel capacity downstream, it is not likely that the structure will be in use. This structure is going to be considered a barrier to fish based on the current political plan to not open the gates.

Photos:

Photo 28 A. Gates upstream



Photo 28\_B. Culvert outlets downstream



Photo 28\_C. Weir downstream culvert outlets, channel looking downstream



Photo 28\_D. Channel upstream and headgates



Title: Sand Slough Control Structure (Sand Slough Connector)

Identification Number: 29

Ranking: Gray

Description: The Sand Slough Control Structure is located at the apex of the San Joaquin River and the Sand Slough near river mile 168.47 (Photo 29\_A). The headgates to Reach 4B are located downstream on the right bank. The control structure is currently acting like a broad-crested weir with 6 rectangular openings each 5.1 x 5 feet (Photo 29\_B). Each opening is designed for slide gates or stop logs that are manually dropped. At the time of the survey the openings were open. The structure has a cobble and concrete headwall that extends the structure to the right and left banks of the channel for a total length of 186 feet from bank to bank. The structure is about 2.5 feet wide and about 5.1 feet high. The structure was partially submerged during the survey.

There is a concrete flume downstream the weir openings that had a concrete apron (Photo 29\_C), so the pool depth downstream is dependent on the amount of flow allowed to enter the structure. The flume is 48.5 feet long and about 15 feet wide at the narrowest part with a height of 4.7 feet. The end of the concrete apron is about 18 feet past the end of the flume, but is sloped down about three feet at the end of the flume and continues to slope down into the channel. The pool depth within three feet downstream had a water surface elevation of 3.3 feet.

The channel upstream had heavy weeds with tall annual grasses in the floodplain and vegetation growing in the openings of the weir (Photo 29\_D). Downstream the channel had light weeds with tall annual grasses in the floodplain (Photo 29\_E).

Evaluation: This site has the potential to be a barrier at different flows. A hydraulic model should be completed to determine at what flows, if any, it is a barrier.

Photos:

Photo 29\_A. Sand Slough Control Structure from the left bank



Photo 29\_B. Sand Slough Control Structure openings looking upstream



Photo 29\_C. Sand Slough Control Structure flume from right bank



Photo 29\_D. Looking upstream from structure headwall



Photo 29\_E. Looking downstream from flume





Title: Washington/Indiana Road Bridge

Identification Number: 30

Rank: Green

Description: The Washington/Indiana bridge crosses perpendicular to the San Joaquin River near river mile 168.0 (Photo 30\_A). The bridge has two lanes with a 124 feet span and 25 feet wide bridge deck and a height of 14.2 feet. The concrete bridge has a total of ten piers with two rows of five that are about 41.5 feet apart. The active channel width was measured at 68 feet.

The river channel upstream is clean with tall annual grasses in the floodplain and dense brush and sparse large woody trees on the banks edge. Downstream the channel and the floodplain vegetation are similar to that of the upstream. The channel banks were too steep to access and the water was very turbid. Channel substrate is assumed silty sand.

Evaluation: The bridge has no apron or riprap scour protection, the bridge span is greater than the active channel width and there is no visible water surface difference between one side of the structure and the other, therefore based on the criteria it is not a barrier to fish migration.

Photos:

Photo 30\_A. Bridge, downstream looking upstream



Title: Turner Island Road Bridge

Identification Number: 32

Rank: Green

Description: The Turner Island bridge crosses the San Joaquin River near river mile 157.2 (Photo 32\_A) at a bend in the river. The bridge has two lanes with a 150 feet span and 34.4 feet wide bridge deck and a height of 10 feet. The concrete bridge has a total of ten piers with two rows off five that are about 30 feet apart. The active channel width was measured at 65 feet.

The water surface elevation was 2.1 feet. The river channel upstream is clean with tall annual grasses in the floodplain and dense brush and sparse large woody trees on the banks edge. Downstream the channel is choked with weeds and water hyacinth, and the channel banks are bare and near vertical but have sparse tall woody trees. The channel banks were too steep to access and the water was very turbid. The channel had a trapezoidal shape with limited capacity and resembled a canal. Channel substrate is assumed silty sand.

Evaluation: The bridge has no apron or riprap scour protection, the bridge span is greater than the active channel width and there is no visible water surface difference between one side of the structure and the other, therefore based on the criteria it is not a barrier to fish migration.

Photos:

Photo 32\_A. Bridge, upstream looking downstream



Photo 32\_B. Channel downstream



Title: Mariposa Bypass Weir (Mariposa Bypass control structure and drop structure)

Identification Number: 35

Rank: Red

Description: The Mariposa Bypass weir is located near the apex of the Mariposa Bypass and the Sand Slough. The weir is acting like a drop structure. The structure is a concrete sharp-crested weir rectangular weir with openings for low flow (Photo 35\_A). The weir height at the opening is 5 feet with a length of 149.5 feet. There is a 17.6 feet drop from downstream. There are 7 openings that are 2 x 2 feet each spaced at 18 feet on center that are at channel grade. The openings are armored upstream with cobble and concrete just at the openings (Photo 35\_B).

There is a large pool downstream that was not accessible due to the depth. The water surface elevation just downstream the weir was 10.1 feet. There was a concrete apron downstream but the distance was not determined. There was concrete just adjacent the wingwall downstream, so it is assumed that the concrete apron extends to the end of the wingwall downstream. The wingwall extends out 90 feet downstream.

The channel upstream and downstream has tall and short annual grasses with tall annual grass in the floodplain and banks. The channel substrate is mostly silt/clay.

Evaluation: There is a hardened apron downstream the weir, it cannot be bypassed, and the height of the weir is greater than two feet.

Photos:

Photo 35\_A. Structure, upstream looking downstream



Photo 35\_B. Low flow openings looking at left bank and wingwall



Photo 35\_C. Structure looking at pool downstream



Title: Beaver Dam #5

Identification Number: 36

Ranking: Gray

Description: The beaver dam was located on the San Joaquin River near river mile 146.1 on private property near the San Luis Wildlife Refuge. A section of the dam was submerged about two feet under the current water surface elevation at a height of 1.6 feet for a length of 17 feet (Photo 36\_A). The dam had a width of 10 feet and a height of 3.6 feet. The water surface elevation upstream was 3.3 feet and 3.6 feet downstream. Vegetation is growing on the top of the exposed section of the dam. There is no defined pool downstream the dam.

The channel upstream and downstream was clean with tall reeds and tall annual grasses on the banks with sparse woody trees.

Evaluation: The dam cannot be bypassed and at lower flows has a drop of less than two feet, but without a staging pool it is going to be recommended to complete a hydraulic model to determine at what flows, if any, it is a barrier.

Photos:

Photo 36 A. Beaver Dam, upstream looking downstream



Title: Beaver Dam #4

Identification Number: 37

Ranking: Gray

Description: The beaver dam was located on the San Joaquin River near river mile 145 on private property near the San Luis Wildlife Refuge. The dam is constructed of woody tree limbs that were placed perpendicular to the channel (Photo 37\_A). The dam had a span of 80 feet and a width of 35 feet. Sand has deposited upstream behind the dam so the depth of the channel increases as you travel upstream. The height was measured at 4.2 feet upstream, the water surface elevation, with a one foot drop downstream. The maximum pool depth downstream was 3.6 feet at a distance of 35 feet from the dam top. The dam had three locations that the water overtopped and spilled over.

The dam had heavy vegetation downstream with tall reeds and water hyacinth (Photo 37\_B). The channel was cleaner about 50 feet downstream the dam. Upstream the channel had patches of tall reeds with tall annual grasses in the floodplain with sparse woody trees (Photo 37\_C). Grazing was allowed in the channel near this location.

Evaluation: The dam cannot be bypassed and has a height greater than two feet, but a water surface elevation drop less than two feet. It is recommended to complete a hydraulic model to determine at what flows, if any, it is a barrier.

Photos:

Photo 37\_A. Beaver Dam at left bank looking upstream



Photo 37\_B. Beaver Dam at right bank



Photo 37\_C. Beaver Dam from upstream looking downstream



Title: Refuge low flow crossing

Identification Number: 38

Ranking: Gray

Description: There is a gravel armored low flow crossing (Photo 38\_A) located on the San Joaquin River near river mile 143.2 within the San Luis Wildlife Refuge that is likely used to provide access to the eastern Bear Creek units. The gravel road appears to be well maintained. The road cannot be bypassed.

The channel upstream (Photo 38\_B) is clean with some tall reeds on the left bank and tall woody trees on the banks located upstream and downstream the crossing. The reeds are choking the channel downstream and may be creating a fish barrier according to DFG (Photo 38\_C). The crossing is about 138 feet from bank to bank with a 24 foot width. The water surface upstream was about 4 feet and about 3 feet downstream. The crossing was submerged at about 1.6 feet depth during the survey and it was not likely to have culverts. The active channel width was estimated at 73 feet.

The crossing was accessed several weeks later and it was noted that the gravel road had some maintenance done. A small channel was created downstream along the left bank by clearing some of the tall reeds and new gravel had been added to the top of the road creating a new water surface elevation of about 14 inches.

Evaluation: The height and width of the crossing may limit passage at lower flows, even though this crossing was submerged during the survey. A second pass survey should be conducted to use hydraulic modeling to determine at what flows, if any, it is a barrier.

Photos:

Photo 38\_A. Crossing from left bank



Photo 38\_B. Channel looking upstream from road





Photo 38\_C. Channel looking downstream at center line of channel



Title: Beaver Dam #3

Identification Number: 39

Rank: Gray

Description: The beaver dam is located on the San Joaquin River near river mile 143.1 on private property adjacent to the San Luis Wildlife Refuge. The beaver dam was partially submerged and likely washed out on the left bank (Photo 39\_A). The dam was measured at 2.5 feet high for about 11 feet and the remainder of the dam was at or just above the water surface elevation. The current water surface elevation was 4.4 feet. The beaver dam was constructed of woody tree limbs of varying size. Vegetation has taken root on the remaining portion of the dam that was above the water surface elevation.

The channel upstream and downstream (Photo 39\_B) was clean with tall reeds on the banks in clusters, tall annual grasses and large woody trees on the bank and floodplain. The maximum pool depth downstream was five feet about fifteen feet from the low section of the dam. The channel substrate was mostly silt/clay.

Evaluation: DFG thought that at current flows this was not a passage issue, but fish passage may be dependent on the depth of flow at this location since the height is greater than two feet. This site is a gray site due to this factor.

Photos:

Photo 39\_A. Beaver dam from downstream looking upstream



Photo 39\_B. Downstream looking downstream



Title: Beaver Dam #2

Identification Number: 40

Ranking: Gray

Description: The beaver dam is located on the San Joaquin River near river mile 137.7 in the San Luis National Wildlife Refuge just upstream Beaver Dam #1. The beaver dam was under water and no details were gathered due to access restrictions (Photo 40\_A). The water at this location was too deep for wading. This may be due to the location within the pool of Beaver Dam #1.

Evaluation: Inspection via a boat may be required to determine if the debris blocks passage.

Photos:

Photo 40\_A. Beaver Dam from upstream looking downstream



Title: Beaver Dam #1

Identification Number: 41

Ranking: Gray

Description: The beaver dam is located on the San Joaquin River near river mile 137.7 in the San Luis National Wildlife Refuge. The dam is constructed of large woody tree branches that have been placed in the channel (Photo 41\_A). The dam has been there for some time, it was seen in the 2007 aerial photos. Refuge staff was not sure of its age. There is a second Beaver Dam upstream, but was not visible due to water depths from the pool created by this dam.

The channel downstream (Photo 41\_B) was clean but shallow in some areas. A small staging pool on the right bank was present adjacent to a sand bar in the center of the channel. Upstream the channel was clean but a large pool was present from the backwatering created by the beaver dam (Photo 41\_C). The backwatering goes up the channel for some distance. The channel banks have large woody trees and tall annual grasses with scatter large woody trees in the floodplain. The staging pool location on the right bank may not be practical since there are some overhanging tree limbs upstream the beaver dam that may impede safe passage. Small minnows were observed just downstream and upstream. Unidentified larger fish were observed downstream and upstream of the dam. One was downstream near a large woody tree limb that was in the channel and two were observed upstream in the pool. The channel bottom majority is silty/clay/sand.

The distance between the terminal points of the woody debris and the channel banks is about 46 feet. The bankfull channel width is about 34 feet. The bottom of the dam base is about 11 feet wide. The water surface elevation is three feet just behind the dam and the dam height was estimated at 3.4 feet upstream and 4.3 feet downstream, this creates a 1.1 foot drop to the channel bed. There was a two foot drop in water surface elevation from the upstream pool to the downstream water surface elevation. There was a small staging pool downstream measuring about 30 feet from the pool tail to the top of the dam. The staging pool was estimated to be about 10 feet deep in the center, but could not be verified since this is too deep to wade.

Evaluation: The beaver dam height is greater than two feet and cannot be bypassed so this is considered a gray site to determine if migrating fish can use the staging pool just downstream to clear the dam height.

Photos:

Photo 41\_A. Beaver Dam from downstream looking upstream



Photo 41\_B. Looking downstream from sand bar



Photo 41\_C. Upstream pool from left bank



Title: Highway 165

Identification Number: 42

Ranking: Green

Description: The Highway 165 bridge crosses perpendicular to the San Joaquin River near river mile 132.8 (Photo 42\_A). The Highway 165 bridge has a 413 feet span and 30 feet wide two-lane bridge deck. The concrete bridge has 104 piers configured in 13 parallel rows of 8. Four of the piers are the original concrete columns and four adjacent steel I-beam piers (W shape) are what appears to be a seismic retrofit. The rows are about 32 feet apart. The active channel width was estimated at 333 feet. There was no apron or rip rap under the bridge.

The river channel upstream is clean with tall annual grasses in the floodplain and large woody trees on the banks edge. Downstream there are tall weeds on a sand bar in the middle of the channel (Photo 42\_B) and the floodplain vegetation was similar to upstream. The channel drops quickly from the edge of the active channel. The channel was too deep to wade, so actual channel depth was not determined. The channel substrate is a majority of silty-clay.

Evaluation: The bridge has no apron or riprap scour protection, the bridge span is greater than the active channel width and there is no visible water surface difference between one side of the structure and the other, therefore based on the criteria it is not a barrier to fish migration.

Photos:

Photo 42\_A. Looking upstream at Highway 165 Bridge



Photo 42\_B. Looking downstream from the photo 42\_A



Title: Highway 140

Identification Number: 43

Ranking: Green

Description: The Highway 140 bridge crosses perpendicular to the San Joaquin River near river mile 125.1 (Photo 43\_A and 43\_B). The Highway 140 bridge has two lanes and has a 516 feet span and 22 feet wide bridge deck. The concrete bridge has 168 piers configured in 24 parallel rows of 7. The rows are about 22 feet apart. The active channel width was measured at 146 feet. There was no apron under the bridge.

The river channel upstream is clean except there are short trees on the sandbars with tall annual grasses in the floodplain and large woody trees on the banks edge. Downstream there are tall weeds on a sand bar in the middle of the channel (Photo 43\_C) and the floodplain vegetation was similar to upstream. Trees appear to be mostly willows. The channel is mostly shallow with the more defined trapezoidal channel on the right bank at about 70 width. The channel substrate is a majority of silty-clay.

Evaluation: The bridge has no apron or riprap scour protection, the bridge span is greater than the active channel width and there is no visible water surface difference between one side of the structure and the other, therefore based on the criteria it is not a barrier to fish migration.

Photos:

Photo 43\_A. Looking downstream at Highway 140 Bridge, left bank



Photos 43\_B. Looking downstream at Highway 140 Bridge, right bank



Photos 43\_C. Looking upstream from bridge





Title: Unnamed Bridge

Identification Number: 44

Ranking: Green

Description: The bridge crosses perpendicular to the Eastside Bypass (Photo 44\_A). The bridge has one lane with a 254.4 feet span, is 18.5 feet high and 18.4 feet wide. The concrete bridge has 28 piers configured in seven parallel rows of four. The rows are about 33 feet apart. The active channel width was measured at 90 feet with about five sets of piers in the water. There was no apron or rip rap under the bridge.

The bypass is bounded by manmade levees upstream and downstream. The channel upstream (Photo 44\_B) and downstream had light weeds in the channel with tall annual grasses in the floodplain and levee with sparse brush and sparse tall woody trees on the banks. There is a pumping station downstream on the left bank (Photo 44\_C).

Evaluation: The bridge has no apron or riprap scour protection, the bridge span is greater than the active channel width and there is no visible water surface difference between one side of the structure and the other, therefore based on the criteria it is not a barrier to fish migration.

Photos:

Photo 44 A. Bridge from upstream looking downstream



Photo 44 B. Channel from upstream looking upstream



Photo 44 A. Channel looking downstream



Title: Unnamed Bridge

Identification Number: 45

Ranking: Green

Description: The bridge crosses perpendicular to the Eastside Bypass (Photo 45\_A). The bridge has one lane with a 120.3 feet span, is 19.5 feet high and 18.5 feet wide. The concrete bridge has 12 piers configured in three parallel rows of four. The rows are about 33 feet apart. The active channel width was measured at 60 feet with about one set of piers in the water. There was no apron or rip rap under the bridge.

The bypass is bounded by manmade levees upstream and downstream. The channel upstream (Photo 45\_B) and downstream has light weeds in the channel with tall annual grasses in the floodplain and levee and sparse brush and sparse tall woody trees on the banks. There is a pumping station downstream on the left bank (Photo 45\_C).

Evaluation: The bridge has no apron or riprap scour protection, the bridge span is greater than the active channel width and there is no visible water surface difference between one side of the structure and the other, therefore based on the criteria it is not a barrier to fish migration.

Photos:

Photo 45\_A. Bridge looking upstream



Photo 45\_B. Channel upstream



Photo 45\_C. Channel downstream looking at pump



Title: Greenhorn Road

Identification Number: 47

Ranking: Green

Description: The Greenhorn Road bridge crosses slightly skewed to the Eastside Bypass (Photo 47\_A). The bridge has one lane with a 181 feet span, is 18.7 feet high and 18.4 feet wide. The concrete bridge has 20 piers configured in five parallel rows of four. The rows are about 30.5 feet apart. The active channel width was measured at 102 feet with about three sets of piers in the water. There was no apron or rip rap under the bridge.

The bypass is bounded by manmade levees upstream and downstream. The channel upstream (Photo 47\_B) and downstream (Photo 47\_C) has light weeds in the channel with tall annual grasses in the floodplain and levee with sparse brush and sparse tall woody trees on the banks. The channel at the bridge had a water surface of 7.6 feet at the deepest. The channel substrate majority is silty-clay.

Evaluation: The bridge has no apron or riprap scour protection, the bridge span is greater than the active channel width and there is no visible water surface difference between one side of the structure and the other, therefore based on the criteria it is not a barrier to fish migration.

Photos:

Photo 47\_A. Greenhorn Road bridge from right bank



Photo 47\_B. Channel upstream from bridge deck



Photo 47\_C. Channel downstream from bridge deck



Title: Eastside Bypass Bifurcation

Identification Number: 48

Ranking: Red

Description: The bifurcation structure is located at the apex of the Eastside Bypass and the Mariposa Bypass (Photo 48\_A). The control structure has six radial gates that were open during the survey. Each gate opening is 19 feet in height and 20 feet wide. The structure height is about 21.5 feet and measures 130.3 feet in total length from the top deck. This structure is very similar to the bifurcation structure located on the San Joaquin River downstream.

The structure has a maintenance road that crosses over the rear of the gate bay with an opening in the center to access the radial gate arms. The hoist motors are located at the top of each bay on the upstream end. There is a solid concrete headwall that extends to the levee to the east and west. The bays are 45.5 feet in length with a 15 foot concrete apron downstream. There are six 2 x 2 x 4 foot concrete block diffusers about 55 feet from the radial gate (Photo 48\_B).

The concrete apron has a short weir downstream that is about 2 feet tall and 1 foot wide. There is a large pool downstream with rip rap to protect the concrete apron and weir from erosion. The rip rap protection extends about 30 feet downstream. The depth of the pool was not determined due to the depth exceeding what was able to be waded. Upstream there is a weir at the inlet that is 4 feet tall. The water surface elevation in the bays was 2.2 feet (Photo 48\_C).

The channel upstream had short and tall annual grasses in the channel with tall annual grasses in the floodplain. The channel downstream had a large pool just downstream the structure and was clean with annual grasses in the channel downstream the pool. The channel substrate was mostly silt/clay.

Two fish were observed just downstream the structure near the rip rap that were about 8 inches in length.

Evaluation: The outlet drop over the weir was measured to be 2.5 feet, which is greater than two feet. Due to the drop at the outlet this structure is not passable to migrating fish at some flows, so it is currently a barrier to fish passage. In addition, the jumping height at the inlet can be greater than two feet at some flows and there is no staging pool because of the concrete bottom of the structure. The structure is also gated. All these factors suggest that the structure is a barrier to fish passage at some flows.

Photos:

Photo 48\_A. Structure, upstream looking downstream



Photo 48\_B. Downstream looking upstream from end of bay



Photo 48\_C. Weir upstream radial gate seal





Title: Mariposa Bypass Bifurcation

Identification Number: 49

Rank: Red

Description: The bifurcation structure is located at the apex of the Eastside Bypass and the Mariposa Bypass (Photo 49\_A). The control structure has 14 bays with 8 radial gates that were partially open during the survey. The radial bays were located on each end of the structure, four at each end. Each bay opening is 10.5 feet in height and 20 feet wide. The structure height is about 20.6 feet, downstream, and measures 295.8 feet in total length from the top deck.

The structure has a maintenance road that crosses over the gate bay. The hoist motors are located at the top of each bay on the upstream end. There is a solid concrete headwall that extended to the north levee that had a gated culvert with a low flow channel. The bays have a roughly five foot drop with concrete diffusers that are 4.4 feet tall and 7.8 feet long (Photo 49\_B). There is a concrete apron downstream for a distance of 45 feet to a weir that was not accessible because of sedimentation and vegetation (Photo 49\_C). The concrete apron had a positive 30 degree angle to the weir.

There is a large pool downstream. The depth of the pool was reported by Reggie Hill to be 30 feet deep. Fish were observed jumping out of the pool. Upstream from there, broken concrete rip rap is in the stream bed of the right channel. The water surface elevation on the apron was 0.6 feet.

The channel upstream was dry and had short and tall annual grasses in the channel with tall annual grasses in the floodplain. A low flow channel was wet and entered a 36 inch culvert. The culvert outlet was located on the right bank wingwall. The channel downstream had a large pool about 106 feet downstream the structure and was clean with annual grasses in the channel downstream the pool. The channel substrate was mostly silt/clay.

Evaluation: The height of the outlet drop was calculated to be 5.1 feet, which is greater than two feet. Due to the height at the outlet this structure is not passable to migrating fish at some flows, so it is currently a barrier to fish passage. In addition, there is no staging pool just downstream because there is a hardened apron.

Photos:

Photo 49\_A. Structure,upstream looking downstream



Photo 49\_B. Ungated bay, downstream looking upstream



Photo 49\_C. Structure, upstream looking downstream



Title: Eastside Bypass Crossing

Identification Number: 50

Rank: Green

Description: The bridge is located on the Eastside Bypass about 1.4 miles upstream the Eastside Bypass bifurcation structure. The crossing (Photo 50\_A) is not publicly accessible and did not have a defined road for access. There was evidence of erosion from overtopping around the bridge deck since the deck was not passable due to an estimated five foot drop from the bridge deck to the adjacent land (Photo 50\_B). According to Reggie Hill, the crossing was constructed to give the private landowner access during low flows. The bridge has a span of 192.2 feet with a width of 18.3 feet and height of 10.9 feet. The water surface elevation was 4.7 feet. The concrete bridge has 20 piers configured in five parallel rows of four. The rows are about 31.5 feet apart. The active channel width was measured at 146 feet. There was no apron or rip rap under the bridge.

The channel upstream and downstream is clean with short grasses on the bank and tall annual grasses in the floodplain.

Evaluation: The bridge has no apron or riprap scour protection, the bridge span is greater than the active channel width and there is no visible water surface difference between one side of the structure and the other, therefore based on the criteria it is not a barrier to fish migration.

Photos:

Photo 50\_A. Bridge, upstream looking downstream



Photo 50\_B. Erosion of bridge on left bank



Title: Dan McNamara Road

Identification Number: 51

Ranking: Gray

Description: Dan McNamara Road is a gravel armored low flow crossing in the Eastside Bypass accessed from Sandy Mush Road (Photo 51\_A). The road is publicly accessible, but had a road closed sign at the time of the survey due to the road being partially submerged. The road width was measured at 50 feet with one culvert in the center of the channel. The bankfull channel width was measured at 175 feet. There was barbed wire fencing just upstream and downstream the crossing so channel measurements were not conducted due to access.

The culvert is a circular corrugated metal pipe with a 30 inch diameter. The culvert length was measured at 50 feet with an inlet/outlet design with no apron. The upstream end of the culvert was backwatered (Photo 51\_E) and appeared to be armored with cobble. The culvert at the outlet was armored with concrete rip rap (Photo 51\_D). The culvert details could not be determined at the time of the survey due to the velocity in the culvert at the outlet and the inlet being submerged. It was assumed that the downstream culvert is at the channel grade.

There appears to be a drop from the upstream channel elevation to the downstream channel elevation. Steps in the channel were observed from the road downstream the crossing that was estimated to be about a total three foot drop over a distance of about 25 feet.

Evaluation: This site is gray because of the hydraulics of the culvert and a full channel survey is needed to determine if this site is a barrier.

Photos:

Photo 51\_A. Dan McNamara Road



Photo 51\_B. Looking upstream from the crossing near the culvert inlet



Photo 51\_C. Looking downstream from the crossing at the culvert outlet



Photo 51\_D. Culvert outlet



Photo 51\_E. Culvert inlet



Title: Sandy Mush Road Bridge

Identification Number: 52

Ranking: Green

Description: The Sandy Mush Road Bridge crosses perpendicular to the Eastside Bypass (Photo 52\_A). The bridge deck has two lanes with a 475.7 feet span, is 40 feet wide and 18.2 feet high. The concrete bridge has 65 piers configured in 13 parallel rows of 5. The rows are about 40 feet apart. The active channel width was estimated at 215.8 feet with about five sets of piers in the water. There was no apron under the bridge.

The bypass is bounded by manmade levees upstream and downstream. Just downstream is the Merced Wildlife Refuge and upstream about 0.675 miles is the Dan McNamara crossing. The channel upstream has short annual grasses with tall annual grasses in the floodplain and tall woody trees on the banks (Photo 52\_C). Downstream the channel has light weeds with tall annual grasses in the floodplain and banks (Photo 52\_B). The channel at the bridge had a water surface of 3.2 feet at the deepest. The channel substrate is a majority of silty-clay.

Evaluation: The bridge has no apron or riprap scour protection, the bridge span is greater than the active channel width and there is no visible water surface difference between one side of the structure and the other, therefore based on the criteria it is not a barrier to fish migration.

Photos:

Photo 52\_A. Sandy Mush Road Bridge looking downstream



Photo 52\_B. Looking upstream from bridge abutment



Photo 52\_C. Looking downstream from bridge



Title: Chamberlain Road Bridge

Identification Number: 53

Rank: Green

Description: Chamberlain Road Bridge (Photo 53\_A) is not publicly accessible and had to be accessed through the Merced Wildlife Refuge. The bridge is located on the Eastside Bypass about 3.5 miles upstream the Sandy Mush Road bridge. The one land bridge has a span of 276 feet with a width of 18.4 feet and height of 8.4 feet. The water surface elevation was 5.3 feet, so at high flows it is likely that the bridge is submerged. The concrete bridge has 24 piers configured in eight parallel rows of four. The rows are about 27 feet apart. The active channel width was measured at 247 feet. There was no apron or rip rap under the bridge.

The channel upstream and downstream is clean with short grasses on the bank and tall annual grasses in the floodplain. There was a small (4-6 inch) fish observed upstream the bridge near the left bank.

Evaluation: The bridge has no apron or riprap scour protection, the bridge span is greater than the active channel width and there is no visible water surface difference between one side of the structure and the other, therefore based on the criteria it is not a barrier to fish migration.

Photos:

Photo 53\_A. Chamberlain Road Bridge, downstream looking upstream





Title: Best Low Flow Crossing

Identification Number: 54

Ranking: Green

Description: This site was not accessed, but a description and photo was provided by program staff that had permission to access the site. There is a non armored low flow crossing (Photo 54\_A) located at W. El Nido Road on the Eastside Bypass one mile north of Washington Road near that is used as a farm equipment crossing to provide quick access to farmland west of the bypass. The dirt road appears to be poorly maintained. The road cannot be bypassed.

The channel is full of vegetation both upstream and downstream and is used for cattle grazing. The crossing is about 1600 feet from bank to bank with a 25 foot width. A culvert in the center line of the main channel used to contain the low flows and allow for equipment crossing at low flows but is now completely buried under sediment. At low flows this crossing becomes unusable for vehicles.

Evaluation: Since this site is at current channel grade, it is not considered a barrier to fish crossing.

Photos:

Photo 54\_A. Crossing at main channel looking west



Title: Washington Road

Identification Number: 55

Ranking: Green

Description: The Washington Road bridge crosses perpendicular to the Sand Slough near river mile 127.7 (Photo 55\_A). The bridge has a one lane 570.9 feet span, is 15.1 feet high and 18.5 feet wide. The concrete bridge has 60 piers configured in 15 parallel rows of 4. The rows are about 35.5 feet apart. The active channel width was estimated at 165 feet with about five sets of piers in the water. There was no apron or rip rap under the bridge.

The slough is bounded by manmade levees upstream and downstream. Just downstream is the Sand Slough control structure (Photo 55\_B). The channel upstream and downstream (Photo 55\_C) has light weeds in the channel with tall annual grasses in the floodplain and levee banks. The channel at the bridge had a water surface of 4.9 feet at the deepest. The channel substrate has a majority of silty-clay.

Evaluation: The bridge has no apron or riprap scour protection, the bridge span is greater than the active channel width and there is no visible water surface difference between one side of the structure and the other, therefore based on the criteria it is not a barrier to fish migration.

Photos:

Photo 55\_A. Washington Bridge looking downstream



Photo 55\_B. Channel looking upstream, sand slough control structure



Photo 55\_C. Channel looking downstream



Title: Rock Weir

Identification Number: 69

Ranking: Gray

Description: The weir is located on private property, that at the time of the inspection were not able to determine access. We have confirmed that we do have access at limited times during the year. The rock weir appears to be acting as a grade control structure to provide back water for a pump upstream. The weir was estimated to have a four foot drop with a length of 40 feet and span of 90 feet. The weir cannot be bypassed.

Evaluation: Since the weir cannot be bypassed and has a height greater than two feet and is not submerged it is recommended to complete a hydraulic model to determine at what flows, if any, the weir is a barrier to fish.

Photos: Photo 69\_A was provided by Craig Moyle, MWH.

Photo 69\_A. Rock weir from downstream looking upstream

Photo 69\_B. Rock weir from upstream looking downstream

